

Features

- Optimized for Cellular Base Station Applications
- Designed for Digital Predistortion Error Correction Systems
- High Terminal Impedances for Broadband Performance
- 48 V Capable Operation
- 100% RF Tested
- RoHS* Compliant

Description

The WSGPC01 GaN HEMT designed for base station applications and optimized for 2.496 - 2.690 GHz modulated signal operation. This device supports pulsed and linear operation with peak output power levels to 6 W (37.8 dBm) in an 4.0 x 4.5 mm DFN package.

Typical RF Performance

- WCDMA 3GPP TM1 64 DPCH 9.9 dB PAR @ 0.01% CCDF, $V_{DS} = 46\text{ V}$, $I_{DQ} = 10\text{ mA}$, $T_C = 25^\circ\text{C}$, $P_{OUT} = 23\text{ dBm}$.

Frequency (GHz)	G_p (dB)	η_D (%)	OPAR (dB)	ACPR (dBc)
2.496	18	13	9.7	-41
2.690	17	12	9.7	-41

Ordering Information

Part Number	Package
WSGPC01-V1-R00A	Bulk Quantity
WSGPC01-V1-R3K	3000 Piece Reel
FXA-WSGPC01V1-1	Driver Sample Board (tuned for 2.496-2.690GHz)



4.0 x 4.5 mm DFN

Functional Schematic

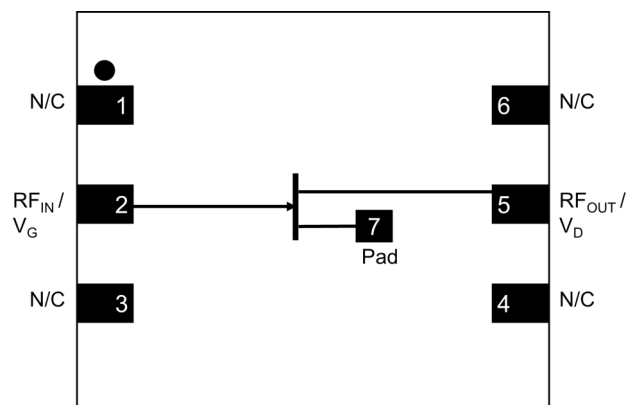

Pin Configuration

Pin #	Function
1,3,4,6 ¹	No Connection ¹
2	RF Input / Gate
5	RF Output / Drain
7	Ground / Source

1. The pad on the package bottom must be connected to RF, DC and thermal ground.

1 * Restrictions on Hazardous Substances, compliant to current RoHS EU directive.

RF Electrical Characteristics: $T_C = 25^\circ\text{C}$, $V_{DS} = 46\text{ V}$, $I_{DQ} = 10\text{ mA}$

Note: Performance in MACOM Single-ended Class-AB Evaluation Test Fixture, 50 Ω system.

Parameter	Test Conditions	Units	Min.	Typ.	Max.
Small Signal Gain	Pulsed ² , 2.6 GHz	dB	—	18.5	—
Saturation Output Power	Pulsed ² , 2.6 GHz	dBm	—	38	—
Drain Efficiency at Saturation	Pulsed ² , 2.6 GHz	%	—	50	—
Power Gain	WCDMA ³ , 2.6 GHz, $P_{OUT} = 23\text{ dBm}$	dB	—	18	—
Drain Efficiency	WCDMA ³ , 2.6 GHz, $P_{OUT} = 23\text{ dBm}$	%	—	12.5	—
Output CCDF @ 0.01%	WCDMA ³ , 2.6 GHz, $P_{OUT} = 23\text{ dBm}$	dB	—	9.7	—
Adjacent Channel Power	WCDMA ³ , 2.6 GHz, $P_{OUT} = 23\text{ dBm}$	dBc	—	-41	—
Input Return Loss	WCDMA ³ , 2.6 GHz, $P_{OUT} = 23\text{ dBm}$	dB	—	-6	—
Ruggedness: Output Mismatch	All Phase Angles	VSWR = 5:1, No Device Damage			

RF Electrical Characteristics: $T_A = 25^\circ\text{C}$, $V_{DS} = 48\text{ V}$, $I_{DQ} = 10\text{ mA}$

Note: Performance in MACOM Single-ended Class-AB Production Test Fixture, 50 Ω system.

Parameter	Test Conditions	Units	Min.	Typ.	Max.
Power Gain	LTE ⁴ , 2.6 GHz, $P_{OUT} = 23\text{ dBm}$	dB	16	17.5	—
Drain Efficiency	LTE ⁴ , 2.6 GHz, $P_{OUT} = 23\text{ dBm}$	%	12.5	15	—
Output CCDF @ 0.01%	LTE ⁴ , 2.6 GHz, $P_{OUT} = 23\text{ dBm}$	dB	6	6.5	—
Adjacent Channel Power Ratio	LTE ⁴ , 2.6 GHz, $P_{OUT} = 23\text{ dBm}$	dBc	—	-37	-33
Input Return Loss	LTE ⁴ , 2.6 GHz, $P_{OUT} = 23\text{ dBm}$	dB	—	-15	-7

2. Pulse details: 20 μs pulse width, 0.2 ms period, 10% Duty Cycle.

3. Modulated Signal: 3.84 MHz, WCDMA 3GPP TM1 64 DPCH, 9.9 dB PAR @ 0.01% CCDF.

4. LTE Signal: 20 MHz, 8 dB PAR @ 0.01% CCDF.

DC Electrical Characteristics: $T_C = 25^\circ\text{C}$

Parameter	Test Conditions	Units	Min.	Typ.	Max.
Drain-Source Leakage Current	$V_{GS} = -8\text{ V}, V_{DS} = 150\text{ V}$	mA	—	—	0.38
Gate-Source Leakage Current	$V_{GS} = -8\text{ V}, V_{DS} = 150\text{ V}$	mA	-0.30	—	—
Gate Threshold Voltage	$V_{DS} = 10\text{ V}, I_D = 0.88\text{ mA}$	V	-3.8	-2.8	-2.1
Gate Quiescent Voltage	$V_{DS} = 48\text{ V}, I_D = 10\text{ mA}$	V	-3.6	-2.4	-2.1
On Resistance	$V_{GS} = 0\text{ V}, I_D = 0.1\text{ mA}$	Ω	—	3.9	—

Absolute Maximum Ratings^{5,6}

Parameter	Absolute Maximum
Drain Source Voltage, V_{DS}	150 V
Gate Source Voltage, V_{GS}	- 10 V to +2 V
Junction Temperature	+225°C
Channel Operating Temperature	-40°C to +225°C
Storage Temperature	- 65°C to +150°C

- 5. Exceeding any one or combination of these limits may cause permanent damage to this device.
- 6. MACOM does not recommend sustained operation near these survivability limits.

Handling Procedures

Please observe the following precautions to avoid damage:

Static Sensitivity

These electronic devices are sensitive to electrostatic discharge (ESD) and can be damaged by static electricity. Proper ESD control techniques should be used when handling these HBM Class 1A and CDM Class C1 devices.

Lead-Free 4.0 x 4.5 mm 6-Lead Package Dimensions[†]

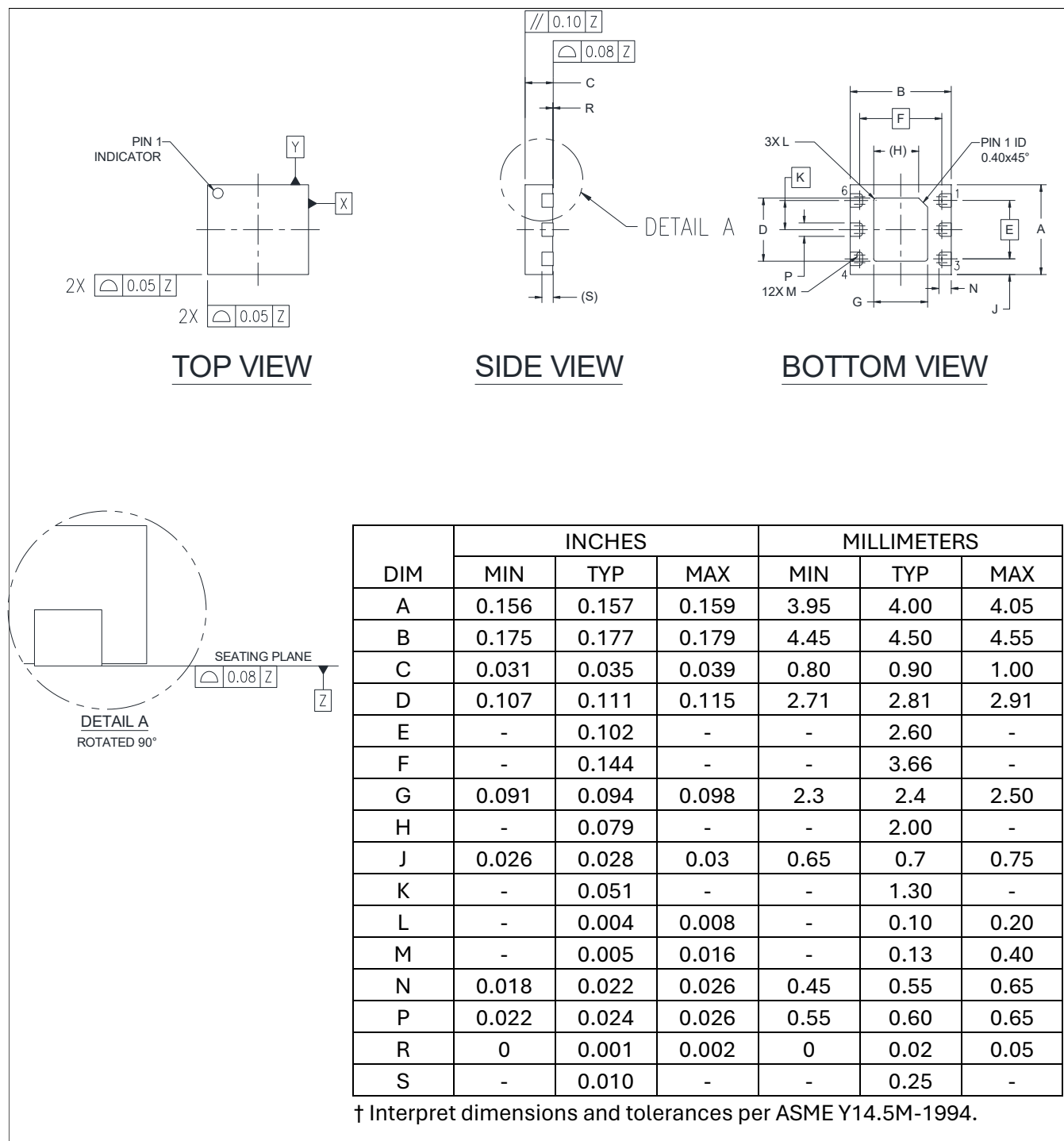

[†] Meets JEDEC moisture sensitivity level (MSL) 3 requirements.
Plating is Sn.

MACOM Technology Solutions Inc. ("MACOM"). All rights reserved.

These materials are provided in connection with MACOM's products as a service to its customers and may be used for informational purposes only. Except as provided in its Terms and Conditions of Sale or any separate agreement, MACOM assumes no liability or responsibility whatsoever, including for (i) errors or omissions in these materials; (ii) failure to update these materials; or (iii) conflicts or incompatibilities arising from future changes to specifications and product descriptions, which MACOM may make at any time, without notice. These materials grant no license, express or implied, to any intellectual property rights.

THESE MATERIALS ARE PROVIDED "AS IS" WITH NO WARRANTY OR LIABILITY, EXPRESS OR IMPLIED, RELATING TO SALE AND/OR USE OF MACOM PRODUCTS INCLUDING FITNESS FOR A PARTICULAR PURPOSE, MERCHANTABILITY, INFRINGEMENT OF INTELLECTUAL PROPERTY RIGHT, ACCURACY OR COMPLETENESS, OR SPECIAL, INDIRECT, INCIDENTAL, OR CONSEQUENTIAL DAMAGES WHICH MAY RESULT FROM USE OF THESE MATERIALS.

MACOM products are not intended for use in medical, lifesaving or life sustaining applications. MACOM customers using or selling MACOM products for use in such applications do so at their own risk and agree to fully indemnify MACOM for any damages resulting from such improper use or sale.