

Features

- Tightly Controlled I-Layer Thickness
- Low Series Resistance: 1.7Ω @ $I_F = 10 \text{ mA}$
- Low Thermal Resistance: 150°C/W
- RoHS* Compliant

Description

The MLP7130-0805-2 silicon limiter PIN diode is a packaged device with a $2 \mu\text{m}$ (nominal) I layer thickness. It is manufactured using a proven diode manufacturing process for high reliability and uniformity.

The very low thermal resistance ($<150^\circ\text{C/W}$) of this device enables it to reliably handle large RF power levels up to 33 dBm CW and RF peak incident power levels up to 47 dBm ($1 \mu\text{s}$ pulse width, 0.1% duty cycle) at $T_A = 25^\circ\text{C}$. The I layer thickness of the diode is tightly controlled to produce consistent input 1 dB compression points in limiter circuits. The low series resistance and total capacitance of the diode combine to produce excellent isolation and insertion loss.

The MLP7130-0805-2 limiter PIN diode is designed for use in moderate-power receiver protection circuit applications. It is suitable for use in the UHF bands and higher for incident peak power levels up to 47 dBm peak. It is durable and capable of reliably operating in military, commercial, and industrial environments.

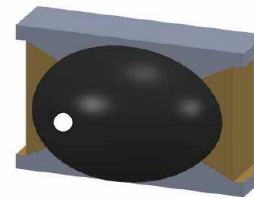

0805-2

Handling Procedures

Please observe the following precautions to avoid damage:

Static Sensitivity

These electronic devices are sensitive to electrostatic discharge (ESD) and can be damaged by static electricity. Proper ESD control techniques should be used when handling these HBM Class 0 devices.

Moisture Sensitivity

These electronic devices are rated MSL 1.

Environmental Capabilities

Capable of meeting the environmental requirements of MIL-STD-750 and MIL-STD-883.

Ordering Information

Part Number	Package
MLP7130-0805-2	400 piece waffle pack

* Restrictions on Hazardous Substances, European Union Directive 2011/65/EU.

Silicon Limiter PIN Diode

Rev. V1

Electrical Specifications: $T_A = +25^\circ\text{C}$

Parameter	Test Conditions	Units	Min.	Typ.	Max.
Breakdown Voltage (V_B)	$I_R = 10 \mu\text{A}$	V	15	30	45
Forward Voltage (V_F)	$I_F = 100 \text{ mA}$	V	—	—	1.1
Total Capacitance ¹ (C_T)	$V_R = 0 \text{ V}, 1 \text{ MHz}$ $V_R = 6 \text{ V}, 1 \text{ MHz}$	pF	—	0.32 0.27	0.38 0.30
Series Resistance ² (R_S)	$I_F = 10 \text{ mA}, 1 \text{ GHz}$	Ω	—	1.7	—
Minority Carrier Lifetime (T_L)	$I_F = 10 \text{ mA}, I_R = 6 \text{ mA}, 50\% \text{ recovery}$	ns	—	5	15
I layer Thickness (W)	—	μm	—	2	—

- Total capacitance (C_T) is the sum of the diode junction capacitance (C_J) and the package capacitance (C_{PKG}).
- Series resistance (R_S) and parallel resistance (R_P) are measured on the HP 4291 Impedance Analyzer.

Absolute Maximum Ratings @ $T_A = +25^\circ\text{C}$

Parameter	Test Conditions	Absolute Maximum
Forward DC Current	—	150 mA
Reverse DC Voltage	—	45 V
Dissipated Power ³	Infinite heat sink, $T_C = 25^\circ\text{C}$	2 W
Thermal Resistance	Junction to case	150°C/W
Junction Temperature	—	+175°C
Operating Temperature	—	-65°C to +150°C
Storage Temperature	—	-65°C to +100°C
Assembly Temperature	$t = 10 \text{ s}$	+285°C

- De-rate linearly to 0 W @ $T_C = 175^\circ\text{C}$

Assembly Instructions

Diodes may be placed onto circuit boards with pick and place manufacturing equipment from tape-reel. The devices are attached to the circuit using conventional solder re-flow or wave soldering procedures with RoHS type or Sn 60 / Pb 40 type solders.

Table 1. Time-Temperature Profile for Sn60/Pb40 or RoHS Type Solders

Profile Feature	SnPb Solder Assembly	Pb-Free Solder Assembly
Average Ramp-Up Rate (T_L to T_P)	3°C /second maximum	3°C /second maximum
Preheat: -Temperature Min (T_{SMIN}) -Temperature Max (T_{SMAX}) -Time (min to max)(t_S)	100°C 150°C 60 - 120 s	150°C 200°C 60 - 180 s
T_{SMAX} to T_L - Ramp-Up Rate		3°C /s maximum
Time Maintained Above: -Temperature (T_L) - Time (t_L)	183°C 60 - 150 s	217°C 60 - 150 s
Peak temperature (T_P)	225 +0/-5°C	260 +0/-5°C
Time Within 5°C of Actual Peak Temperature (t_P)	10 – 30 s	20 – 40 s
Ramp-Down Rate	6°C /s maximum	6°C /s maximum
Time 25°C to Peak Temperature	6 minutes maximum	8 minutes maximum

Figure 1. Solder Re-Flow Time-Temperature Profile

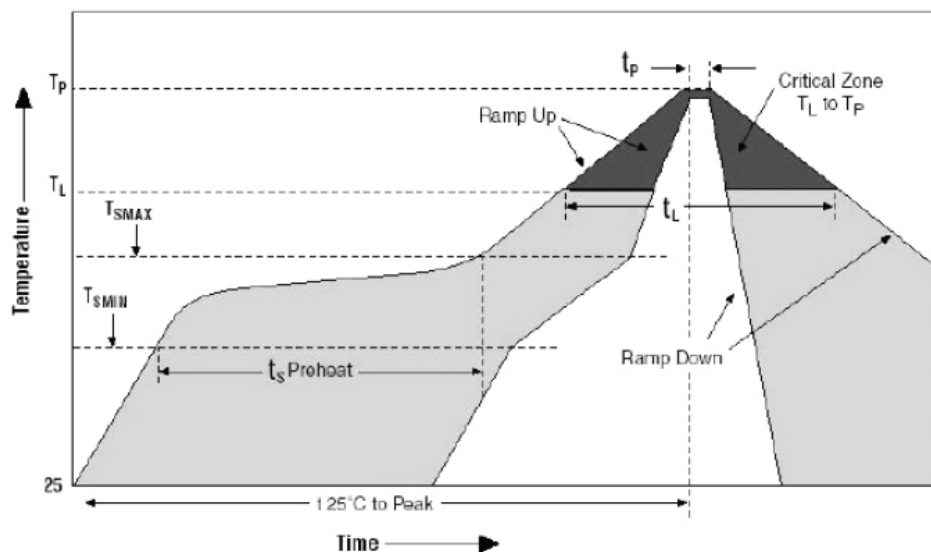

Outline (0805-2)

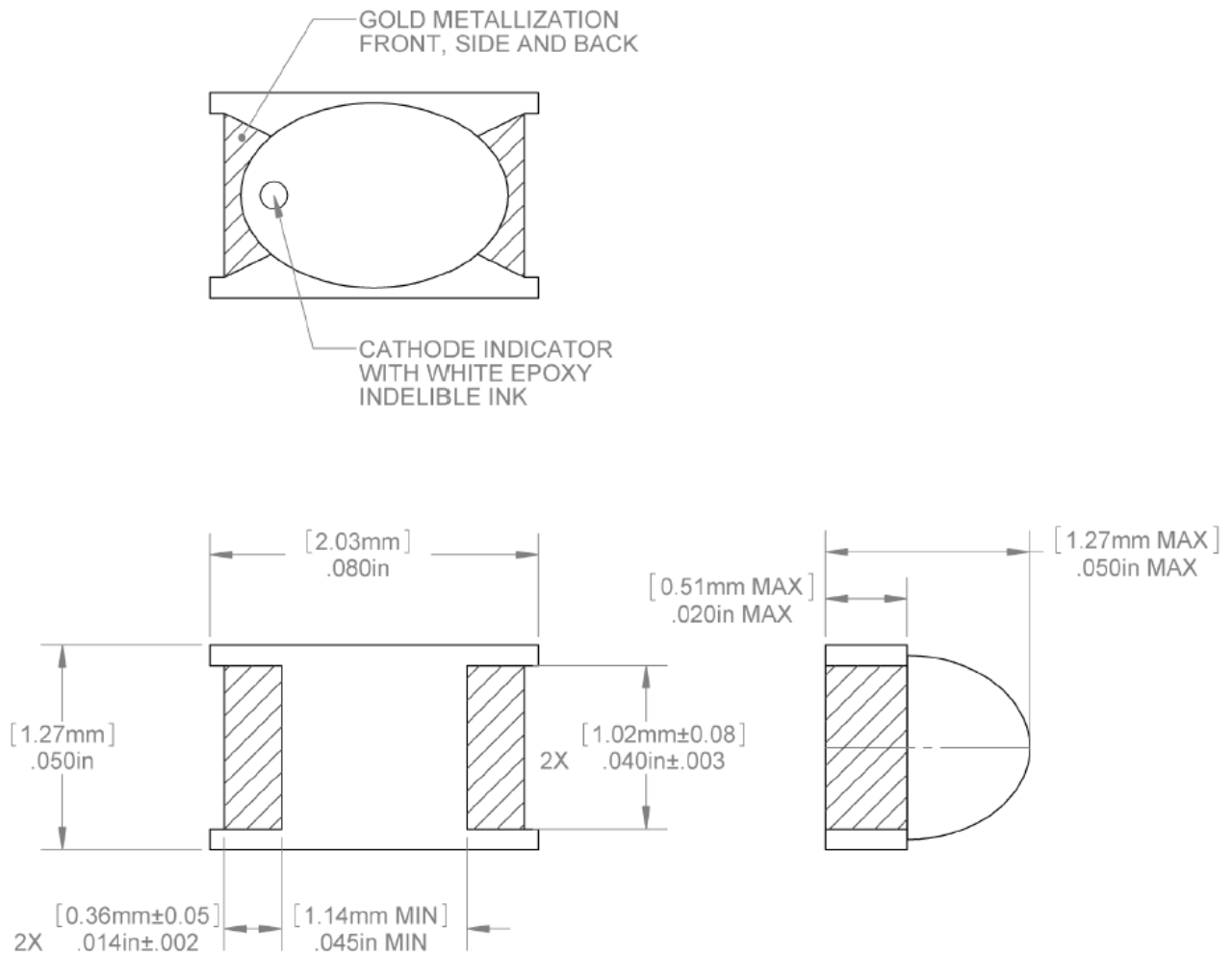

MACOM Technology Solutions Inc. All rights reserved.

Information in this document is provided in connection with MACOM Technology Solutions Inc ("MACOM") products. These materials are provided by MACOM as a service to its customers and may be used for informational purposes only. Except as provided in MACOM's Terms and Conditions of Sale for such products or in any separate agreement related to this document, MACOM assumes no liability whatsoever. MACOM assumes no responsibility for errors or omissions in these materials. MACOM may make changes to specifications and product descriptions at any time, without notice. MACOM makes no commitment to update the information and shall have no responsibility whatsoever for conflicts or incompatibilities arising from future changes to its specifications and product descriptions. No license, express or implied, by estoppel or otherwise, to any intellectual property rights is granted by this document.

THESE MATERIALS ARE PROVIDED "AS IS" WITHOUT WARRANTY OF ANY KIND, EITHER EXPRESS OR IMPLIED, RELATING TO SALE AND/OR USE OF MACOM PRODUCTS INCLUDING LIABILITY OR WARRANTIES RELATING TO FITNESS FOR A PARTICULAR PURPOSE, CONSEQUENTIAL OR INCIDENTAL DAMAGES, MERCHANTABILITY, OR INFRINGEMENT OF ANY PATENT, COPYRIGHT OR OTHER INTELLECTUAL PROPERTY RIGHT. MACOM FURTHER DOES NOT WARRANT THE ACCURACY OR COMPLETENESS OF THE INFORMATION, TEXT, GRAPHICS OR OTHER ITEMS CONTAINED WITHIN THESE MATERIALS. MACOM SHALL NOT BE LIABLE FOR ANY SPECIAL, INDIRECT, INCIDENTAL, OR CONSEQUENTIAL DAMAGES, INCLUDING WITHOUT LIMITATION, LOST REVENUES OR LOST PROFITS, WHICH MAY RESULT FROM THE USE OF THESE MATERIALS.

MACOM products are not intended for use in medical, lifesaving or life sustaining applications. MACOM customers using or selling MACOM products for use in such applications do so at their own risk and agree to fully indemnify MACOM for any damages resulting from such improper use or sale.