

High Power Reflective SP3T Surface Mount Switch, 30 MHz - 5 GHz



MASW-011208

Rev. V2

Features

- Higher Power SMT Switch
- Operating Frequency: 30 MHz - 5 GHz
- CW Power Handling:
52.5 dBm @ +25°C, 3.5 GHz
- Peak Power Handling:
62.0 dBm @ +25°C, 3.5 GHz
- Insertion Loss: 0.5 dB
- Return Loss: 12 dB
- Isolation: 40 dB
- T_{ON} Switching Speed: 6 μs
- Input IP3: 70 dBm
- RoHS* Compliant
- Higher Reliability Compared to Electromechanical Switches

Applications

- Aerospace and Defense
- Space

Description

The MASW-011208 is a 30 MHz - 5 GHz reflective surface mount SP3T switch that uses 5 V VDC and 200 V VDC positive voltage only for successful high RF power operation. This product provides an exceptional isolation to insertion loss ratio of 40 dB to 0.8 dB at 5 GHz, with 6 μs switching speed in a 23 x 16 x 3 mm BeO ceramic housing. It is ideally suited for applications requiring higher RF power surface mount switching applications.

Ordering Information

Part Number	Package
MASW-011208	Parts in Gel-Pak
MASW-011208-SMB	Sample Test Board

Functional Schematic

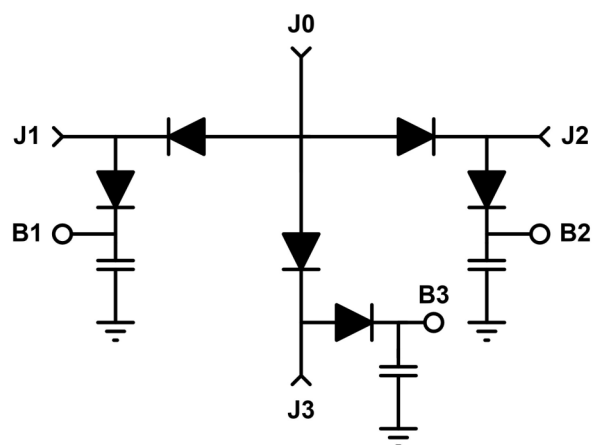

Port Configuration¹

Port Description	Function
J0	RF Input
J1	RF Output 1
J2	RF Output 2
J3	RF Output 3
B1	DC Bias for J1 Shunt Diode
B2	DC Bias for J2 Shunt Diode
B3	DC Bias for J3 Shunt Diode
GND	RF & DC Voltage Ground Return

1. The backside of the SP3T substrate must be directly connected to thermal, DC, and RF Ground for proper and successful operation.

* Restrictions on Hazardous Substances, compliant to current RoHS EU directive.

High Power Reflective SP3T Surface Mount Switch, 30 MHz - 5 GHz



MASW-011208

Rev. V2

**Electrical Specifications: $T_A = 25^\circ\text{C}$, $P_{IN} = 0 \text{ dBm}$, $Z_0 = 50 \Omega$,
DC Power = 5 V @ 200 mA (Insertion Loss), 200 V @ 25 mA (Isolation)**

Parameter	Test Conditions	Units	Min.	Typ.	Max.
Insertion Loss, J0-J1, J0-J2, and J0-J3	1.0 GHz	dB	—	0.2	0.6
	2.5 GHz			0.5	0.9
	4.0 GHz			0.4	0.9
	5.0 GHz			0.7	1.3
Return Loss, J0-J1, J0-J2, and J0-J3	1.0 GHz	dB	—	18	—
	2.5 GHz			12	
	4.0 GHz			20	
	5.0 GHz			12	
Isolation, J0-J1, J0-J2, and J0-J3	1.0 GHz	dB	55	65	—
	2.5 GHz		42	47	
	4.0 GHz		35	40	
	5.0 GHz		32	38	
Switching Speed (T_{ON}) ³	3.5 GHz, 10 kHz TTL repetition rate (50% Control Voltage - 90% RF Voltage)	μs	—	6	—
Switching Speed (T_{OFF}) ³	3.5 GHz, 10 kHz TTL repetition rate (50% Control Voltage - 10% RF Voltage)	μs	—	3	—
CW Incident Power ²	3.5 GHz	dBm	—	52.5	—
Peak Incident Power ²	3.5 GHz, RF pulse width = 100 μs , 5% duty cycle		—	62	—
Input IP3	F1 = 2.000 GHz, F2 = 2.010 GHz 39 dBm per tone power	dbm	—	71	—

2. Maximum source and load VSWR = 1.2:1 each.
3. Switching speed measured in commutating mode.

Nominal Operating Conditions^{4,5}

Parameter	Nominal Value
CW Incident Power ²	52.5 dBm @ +25°C 52.0 dBm @ +55°C 50.5 dBm @ +85°C
Peak Incident Power ²	100 μs , 5% duty 62.0 dBm @ +25°C 61.0 dBm @ +85°C
DC Operating Voltage & Current Bias +V _{CC} +V _{DD}	5 \pm 3% V @ 200 mA 200 \pm 3% V @ 25 mA
Operating Temperature	-40°C to +85°C
Storage Temperature	-40°C to +85°C

4. Operating at nominal conditions with $T_J \leq +175^\circ\text{C}$ will ensure MTBF > 1 x 10⁶ hours.
5. Maximum Source VSWR = 1.2 :1 and Load VSWR = 1.2:1

Maximum Survivability Ratings^{6,7}

Parameter	Absolute Maximum
CW Incident Power ²	53.0 dBm @ +25°C 52.5 dBm @ +55°C 51.0 dBm @ +85°C
Peak Incident Power ²	100 μs , 5% duty 62.5 dBm @ +25°C 61.5 dBm @ +85°C
DC Operating Voltage & Current Bias +V _{CC} +V _{DD}	5 \pm 5% V @ 250 mA 200 \pm 5% V @ 40 mA
Operating Temperature	-40°C to +85°C
Storage Temperature	-40°C to +85°C

6. Exceeding any one or combination of these limits may cause permanent damage to this device.
7. MACOM does not recommend sustained operation near any of these maximum survivability limits.

DC Bias to RF Truth Table⁸

Insertion Loss Typical Bias State = 5 V @ 200 mA, Isolation Bias Typical State = 200 V @ 25 mA

RF State	J0 Bias (B0)	J1 Bias (B4)	B1Bias	J2 Bias (B5)	B2 Bias	J3 Bias (B6)	B3 Bias
J0-J1 Insertion Loss & J0-J2, J0-J3 Isolation	5 V @ 200 mA	0 V @ 200 mA	200 V @ 0 mA	200 V @ 25 mA	0 V @ 25 mA	200 V @ 25 mA	0 V @ 25 mA
J0-J2 Insertion Loss & J0-J1, J0-J3 Isolation	5 V @ 200 mA	200 V @ 25 mA	0 V @ 25 mA	0 V @ 200 mA	200 V @ 0 mA	200 V @ 25 mA	0 V @ 25 mA
J0-J3 Insertion Loss & J0-J1, J0-J2 Isolation	5 V @ 200 mA	200 V @ 25 mA	0 V @ 25 mA	200 V @ 25 mA	0 V @ 25 mA	0 V @ 200 mA	200 V @ 0 mA
J0-J1, J0-J2, J0-J3 Isolation	0 V @ 0 mA	200 V @ 25 mA	0 V @ 25 mA	200 V @ 25 mA	0 V @ 25 mA	200 V @ 25 mA	0 V @ 25 mA

8. Current limiting resistors are required for proper DC bias operation and are shown in the switch applications schematic.

Applications Bias Network Schematic

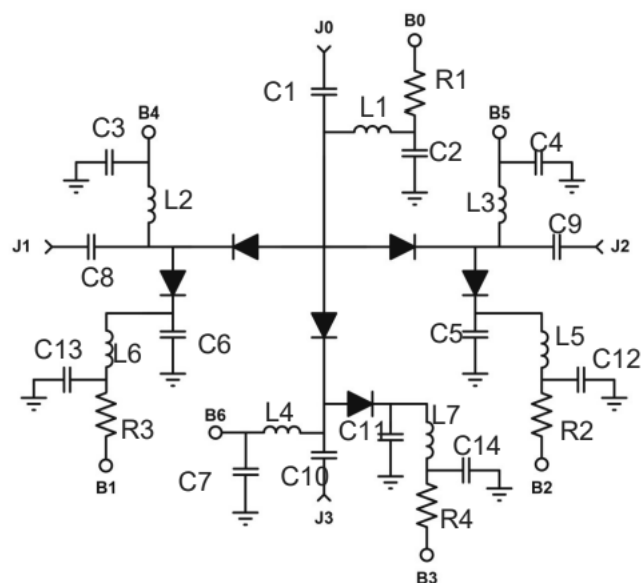

Off-Chip Component Values (1 - 5 GHz)

Component	Value
C1, C8, C9, C10	10 nF
C2 - C7, C11 - C14	33 pF
L1 - L4	18.7 nH
L5 - L7	1.8 nH
R1	12 Ω
R2 - R4	7.5 kΩ

Handling Procedures

Please observe the following precautions to avoid damage:

Static Sensitivity

These electronic devices are sensitive to electrostatic discharge (ESD) and can be damaged by static electricity. Proper ESD control techniques should be used when handling these devices.

Typical Performance Curves⁹:

S-Parameter measurements are made on switches soldered to RF evaluation board with high power bias components in the band shown.

J0-J1 Insertion Loss

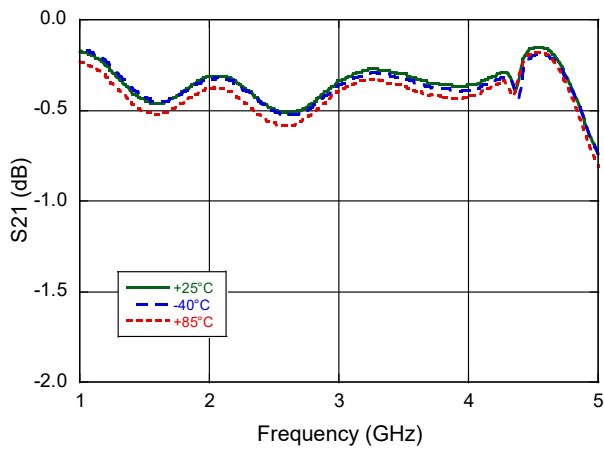

J0-J2 Insertion Loss

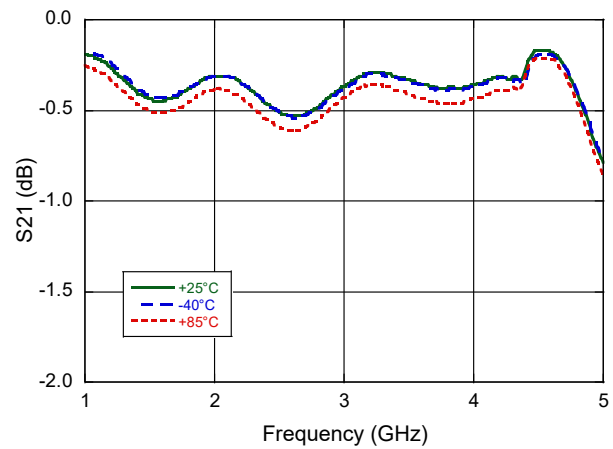

J0-J3 Insertion Loss

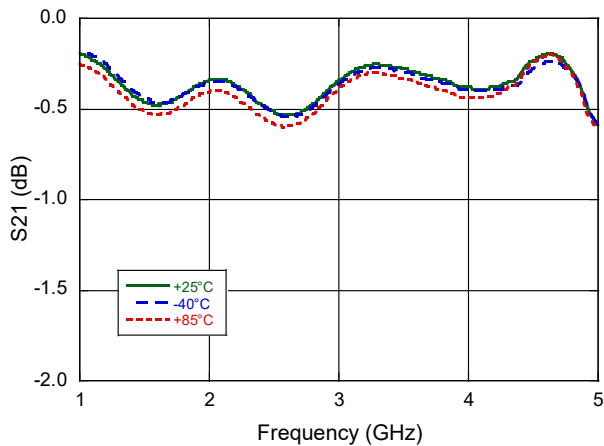

9. Switches are capable of operating down to 30 MHz with broadband bias components.

High Power Reflective SP3T Surface Mount Switch, 30 MHz - 5 GHz



MASW-011208

Rev. V2

Typical Performance Curves:

S-Parameter measurements are made on switches soldered to RF evaluation board with high power bias components in the band shown.

J0-J1 Input Return Loss

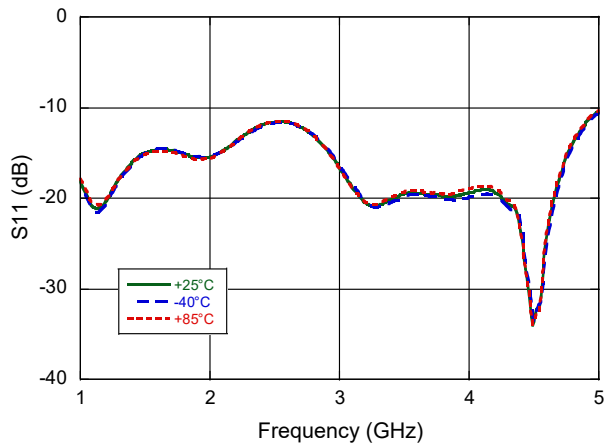

J0-J2 Input Return Loss

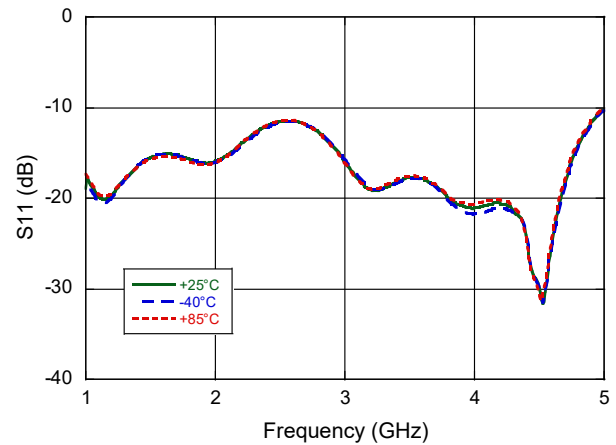

J0-J3 Input Return Loss

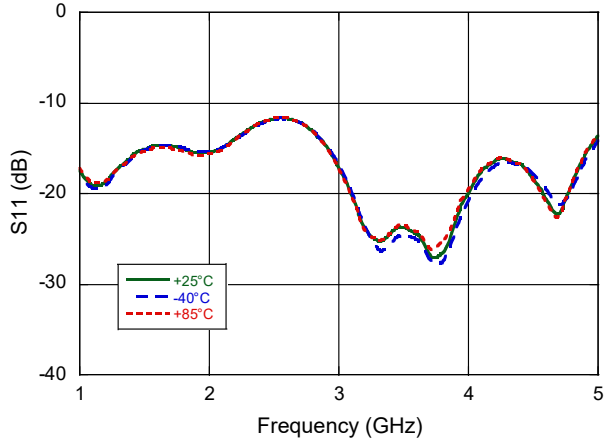

Typical Performance Curves:

S-Parameter measurements are made on switches soldered to RF evaluation board with high power bias components in the band shown. Isolation inflection peak is due to ground resonance in RF evaluation board due to high power bias components.

J0-J1 Isolation

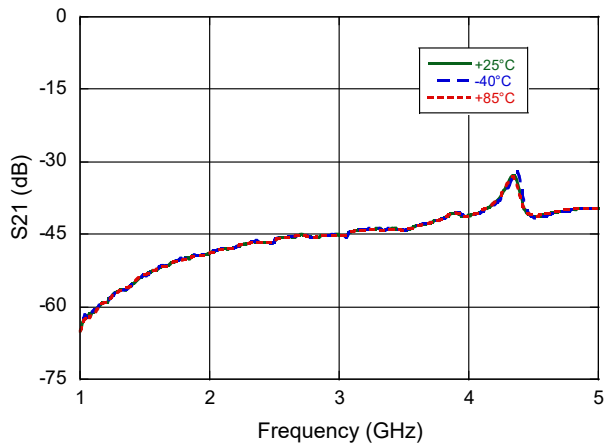

J0-J2 Isolation

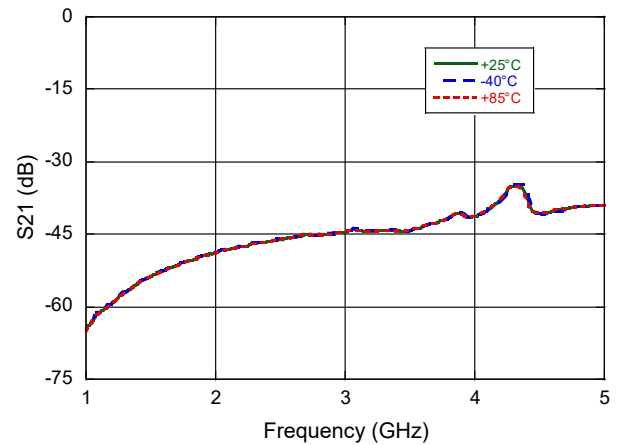

J0-J3 Isolation

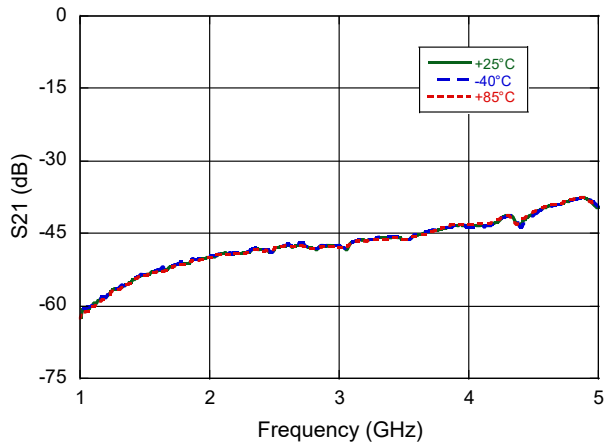

High Power Reflective SP3T Surface Mount Switch, 30 MHz - 5 GHz



MASW-011208

Rev. V2

Outline Drawing

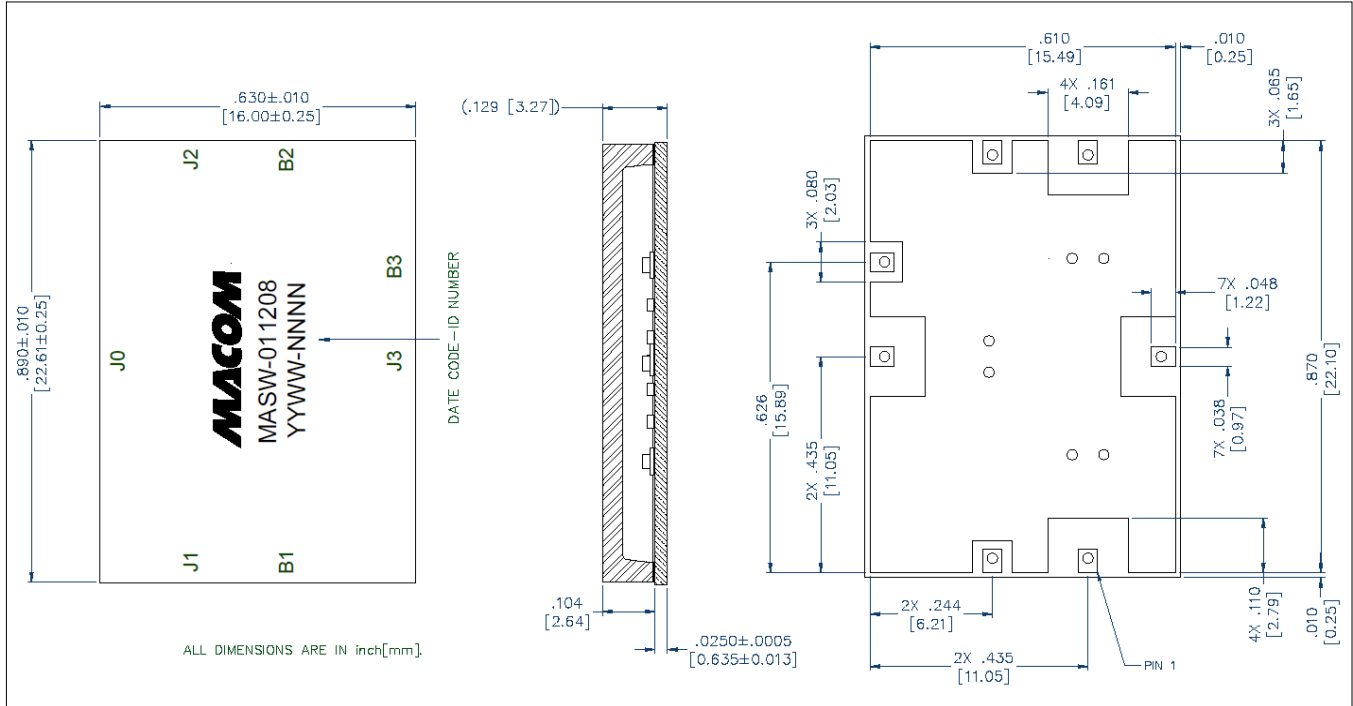

MACOM Technology Solutions Inc. ("MACOM"). All rights reserved.

These materials are provided in connection with MACOM's products as a service to its customers and may be used for informational purposes only. Except as provided in its Terms and Conditions of Sale or any separate agreement, MACOM assumes no liability or responsibility whatsoever, including for (i) errors or omissions in these materials; (ii) failure to update these materials; or (iii) conflicts or incompatibilities arising from future changes to specifications and product descriptions, which MACOM may make at any time, without notice. These materials grant no license, express or implied, to any intellectual property rights.

THESE MATERIALS ARE PROVIDED "AS IS" WITH NO WARRANTY OR LIABILITY, EXPRESS OR IMPLIED, RELATING TO SALE AND/OR USE OF MACOM PRODUCTS INCLUDING FITNESS FOR A PARTICULAR PURPOSE, MERCHANTABILITY, INFRINGEMENT OF INTELLECTUAL PROPERTY RIGHT, ACCURACY OR COMPLETENESS, OR SPECIAL, INDIRECT, INCIDENTAL, OR CONSEQUENTIAL DAMAGES WHICH MAY RESULT FROM USE OF THESE MATERIALS.

MACOM products are not intended for use in medical, lifesaving or life sustaining applications. MACOM customers using or selling MACOM products for use in such applications do so at their own risk and agree to fully indemnify MACOM for any damages resulting from such improper use or sale.