

AlGaAs SP2T PIN Diode Switch with integrated bias circuits Wideband, 80 - 100 GHz



MASW-011111-DIE
Rev. V2

Features

- 80 - 100 GHz Broadband Operating Frequency
- 0.8 dB Insertion Loss
- 25 dB Isolation
- Silicon Nitride Passivation
- BCB Scratch Protection
- Lead-Free AlGaAs MMIC Die
- Die Size: 1.33 x 1.055 x 0.1 mm
- RoHS* Compliant

Applications

- ISM / MM

Description

The MASW-011111-DIE is a wideband SP2T switch manufactured using MACOM's patented AlGaAs PIN Diode MMIC process on a semi-insulating GaAs substrate. The device is fully passivated with silicon nitride and has an additional layer of BCB for scratch protection. This protective coating prevents damage to the circuit during automated or manual handling. These devices are suitable for pick and place insertion.

Each RF port contains DC blocking capacitors and a DC bias circuit consisting of high impedance lines and RF radial stubs. This device has gold plated bonding pads at all RF and DC ports. RF and DC ground backside gold plating allows conventional chip bonding techniques using 80Au/20Sn solder, Indalloy solder, or electrically conductive silver epoxy.

Applications include satellite communications, millimeter-wave radar, and 94 GHz imaging in astronomy, defense, and security applications.

Ordering Information

Part Number	Package
MASW-011111-DIE	Waffle Pak

Functional Schematic

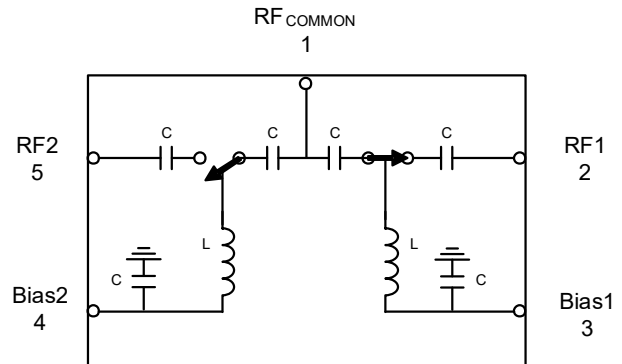

Pin Configuration¹

Pin #	Function
1	RF _{COMMON}
2	RF1
3	Bias1
4	Bias2
5	RF2

1. The die backside must be connected to RF, DC and thermal ground.

* Restrictions on Hazardous Substances, compliant to current RoHS EU directive.

Electrical Specifications: $T_A = 25^\circ\text{C}$, +10 mA / -4.5 V, $Z_0 = 50 \Omega$

Parameter	Test Conditions	Units	Min.	Typ.	Max.
Insertion Loss	80 - 100 GHz	dB	—	0.8	—
Isolation	80 - 100 GHz	dB	—	25	—
RF _{COMMON} Return Loss	80 - 100 GHz	dB	—	16	—
RF1, RF2 Return Loss	80 - 100 GHz	dB	—	20	—
Forward Bias	10 mA	V	—	1.34	—
Switching Speed	10% - 90% RF Voltage	ns	—	20	—

Truth Table & Bias Conditions

RF Inputs	Bias1	Bias2
RF _{COMMON} to RF1	-4.5 V ²	10 mA ³
RF _{COMMON} to RF2	10 mA ³	-4.5 V ²

- Minimum reverse bias voltage (V_R) should be determined based on working conditions. For example, $V_R = -4.5 \text{ V}$ @ 23 dBm input power. For lower power applications, a less negative voltage can be used. R. Caverly and G. Hiller, "Establishing the Minimum Reverse Bias for a PIN Diode in a High Power Switch," IEEE Transactions on Microwave Theory and Techniques, Vol.38, No.12, December 1990. For higher linearity the V_R may be increased to -25 V.
- Forward bias current (I_F) is set using external bias resistors (R_{BIAS}) placed at pins Bias1 and Bias2, where $R_{BIAS} = (V_{CC} - 1.32 \text{ V}) / I_F$.

Absolute Maximum Ratings^{4,5}

Parameter	Absolute Maximum
Input Power	30 dBm
Forward Bias Current	15 mA
Reverse Bias Voltage	-50 V
Junction Temperature ⁶	+150°C
Operating Temperature	-55°C to +85°C
Storage Temperature	-65°C to +150°C

- Exceeding any one or combination of these limits may cause permanent damage to this device.
- MACOM does not recommend sustained operation near these survivability limits.
- Operating at nominal conditions with $T_J \leq +150^\circ\text{C}$ will ensure MTBF > 1×10^6 hours.

Handling Procedures

Please observe the following precautions to avoid damage:

Static Sensitivity

These electronic devices are sensitive to electrostatic discharge (ESD) and can be damaged by static electricity. Proper ESD control techniques should be used when handling these HBM Class 0 devices.

Typical Performance Curves

Insertion Loss RF_{COMMON} to RF_x

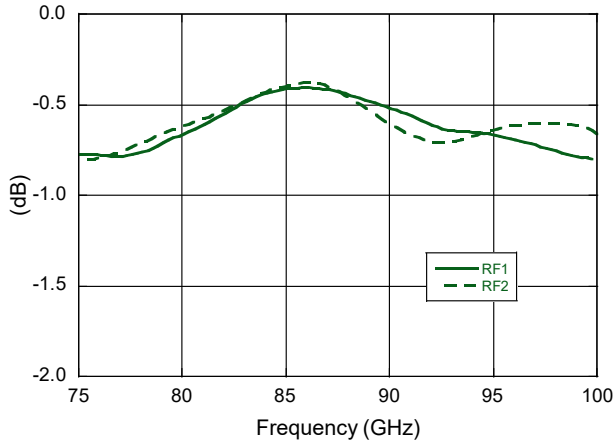

Isolation RF_{COMMON} to RF_x

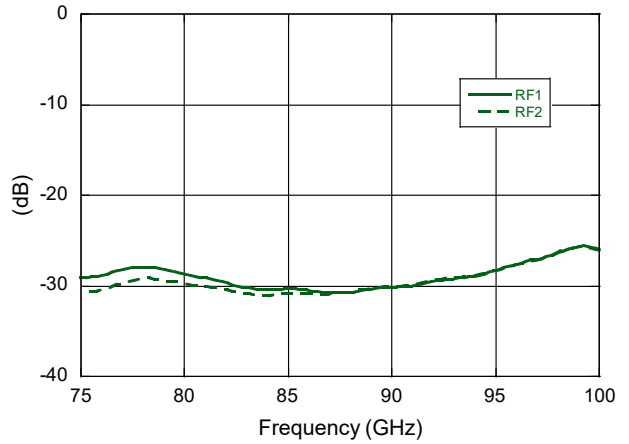

RF_{COMMON} Return Loss in ON State

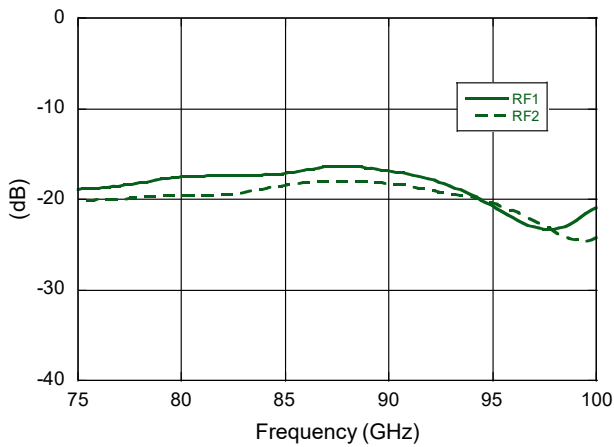

RF_x Return Loss in On State

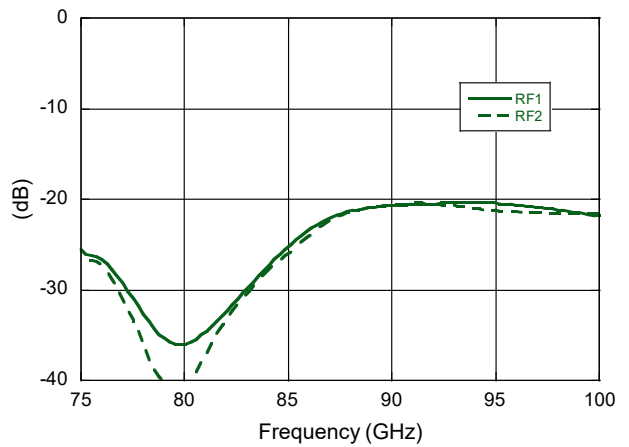

MASW-011111-DIE with MADR-011022 Driver Application Schematic

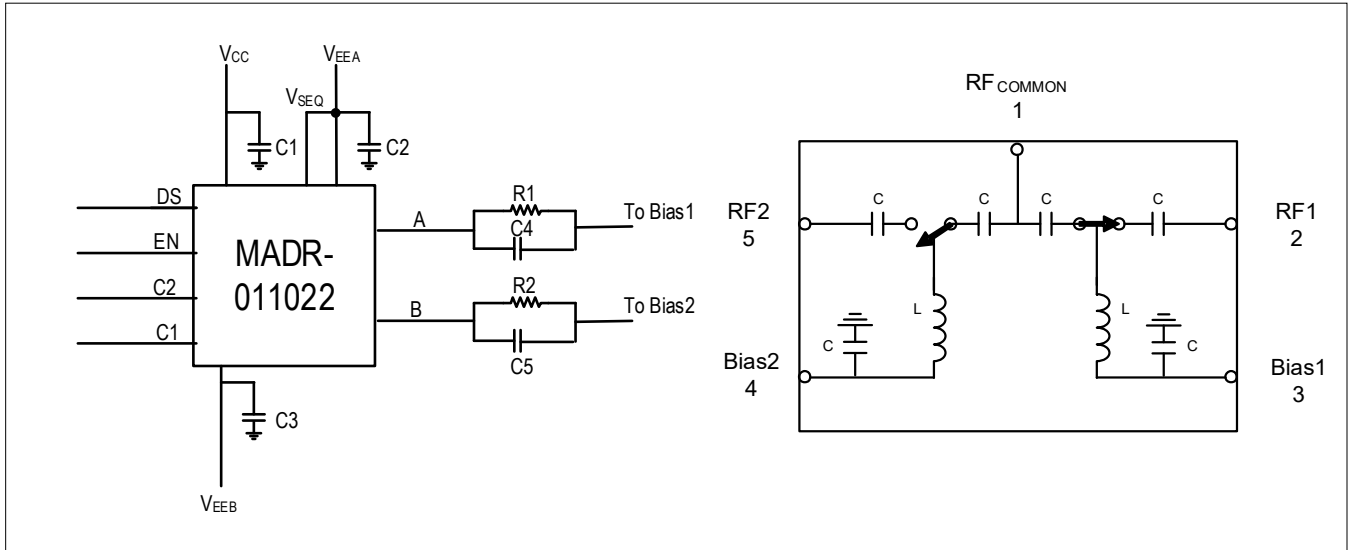

Parts List⁷

Part	Value
C1,C3	0.1 μ F
C2	47 pF
C4,C5	470 pF
R1,R2	360 Ω

7. Resistor values calculated to provide ~10 mA of bias current given $V_{CC} = 5$ V, $V_{EEB} = -10$ to -25 V, voltage drop at driver output 0.4 V, V_f of switch diodes 1.32 V and V_R at Bias1 and Bias2 equal to V_{EEB} minus 0.4 V.

Solder Die Attach

All die attach and bonding methods should be compatible with gold metal. Solder which does not scavenge gold, such as 80 Au/20 Sn or Indalloy #2, is recommended. Do not expose die to a temperature greater than 300°C for more than 10 seconds.

Electrically Conductive Epoxy Die Attach

Assembly can be preheated to approximately 125°C. Use a controlled thickness of approximately 1 mils for best electrical conductivity and lower thermal resistance. A thin epoxy fillet should be visible around the perimeter of the chip after placement. Cure epoxy per manufacturer's schedule. For extended cure times, temperatures should be kept below 150°C.

Wire / Ribbon Bonding

Wedge thermo compression bonding may be used to attach ribbons to the RF bonding pads. Gold ribbons should be at least 1/4 by 2 mil for lowest inductance. The same gold ribbon or 1 mil dia. gold wire is recommended for all DC pads.

Outline Drawing

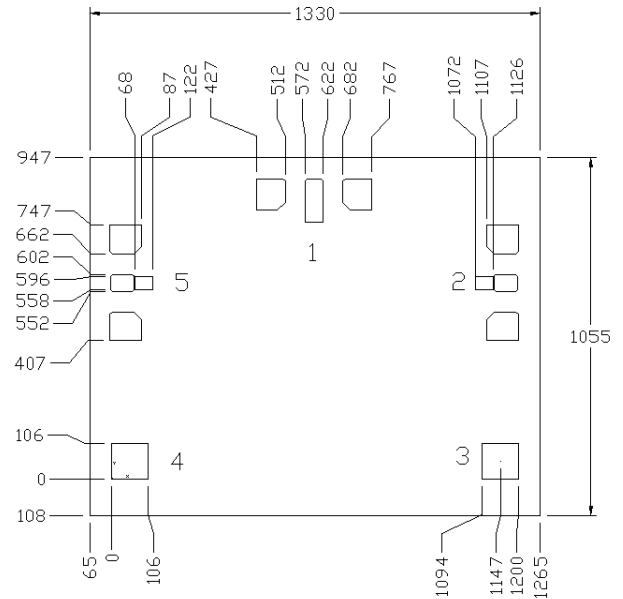

Dimensions are in μm.

MACOM Technology Solutions Inc. ("MACOM"). All rights reserved.

These materials are provided in connection with MACOM's products as a service to its customers and may be used for informational purposes only. Except as provided in its Terms and Conditions of Sale or any separate agreement, MACOM assumes no liability or responsibility whatsoever, including for (i) errors or omissions in these materials; (ii) failure to update these materials; or (iii) conflicts or incompatibilities arising from future changes to specifications and product descriptions, which MACOM may make at any time, without notice. These materials grant no license, express or implied, to any intellectual property rights.

THESE MATERIALS ARE PROVIDED "AS IS" WITH NO WARRANTY OR LIABILITY, EXPRESS OR IMPLIED, RELATING TO SALE AND/OR USE OF MACOM PRODUCTS INCLUDING FITNESS FOR A PARTICULAR PURPOSE, MERCHANTABILITY, INFRINGEMENT OF INTELLECTUAL PROPERTY RIGHT, ACCURACY OR COMPLETENESS, OR SPECIAL, INDIRECT, INCIDENTAL, OR CONSEQUENTIAL DAMAGES WHICH MAY RESULT FROM USE OF THESE MATERIALS.

MACOM products are not intended for use in medical, lifesaving or life sustaining applications. MACOM customers using or selling MACOM products for use in such applications do so at their own risk and agree to fully indemnify MACOM for any damages resulting from such improper use or sale.