

Features

- MACOM PURE CARBIDE™ Amplifier Series
- Suitable for Linear & Saturated Applications
- CW & Pulsed Operation: 2 KW Output Power
- Input and Output Matched to 50 Ω
- Integrated Bias Controller/Sequencer
- 80 V Operation
- 100% RF Tested

Applications

- Avionics

Description

The MAPC-P1008 is a 50 Ohm matched high power GaN on Silicon Carbide HEMT D-mode pallet amplifier suitable for 0.960 - 1.215 GHz frequency operation. The device supports pulsed operation with output power levels of 2 KW (63.0 dBm).

Typical Performance:

- Measured at 2.5 dB compression, 100 μs pulse width, 1% duty cycle
- $V_{DS} = 80\text{ V}$, $T_C = 25^\circ\text{C}$, $I_{DQ} = 400\text{ mA}$

Frequency (GHz)	Output Power (dBm)	Gain (dB)	η_D (%)
0.960	64.7	16.8	57
1.10	63.6	15.9	57
1.215	63.7	15.8	64

Functional Schematic

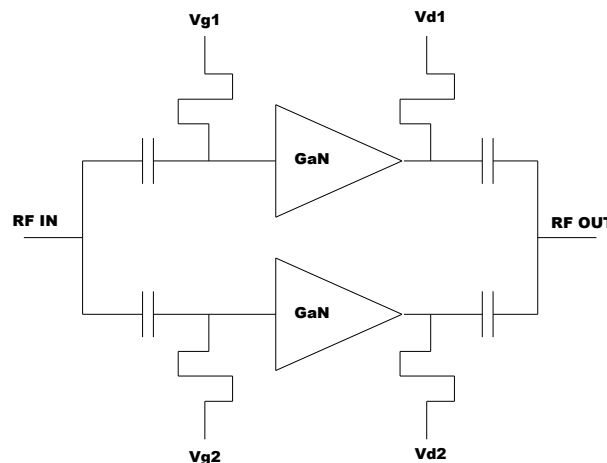

Pin Configuration

Pin Name	Function
V_{D1}, V_{D2}	Drain Voltage
V_{G1}, V_{G2}	Gate Voltage
RF IN	RF Input
RF OUT	RF Output

Ordering Information

Part Number	Configuration
MAPC-P1008-AB000	Microstrip RF Launch
MAPC-P1008-ABSB1	SMA Connectorized

GaN Amplifier Pallet, 80 V, 2 KW

0.960 - 1.215 GHz



MACOM PURE CARBIDE™

MAPC-P1008

Rev. V1

**RF Electrical Characteristics: $T_C = 25^\circ\text{C}$, $V_{DS} = 80\text{ V}$, $I_{DQ} = 400\text{ mA}$,
Note: Performance in MACOM Evaluation Test Fixture, 50 Ω system**

Parameter	Test Conditions	Symbol	Min.	Typ.	Max.	Units
Small Signal Gain	Pulsed ¹ , 0.960 GHz 1.10 GHz 1.215 GHz	G_{SS}	—	18.0	—	dB
Power Gain	Pulsed ¹ , 2.5dB Gain Compression, 0.960 GHz 1.10 GHz 1.215 GHz	G_{SAT}	—	15.5 15.6 15.0	—	dB
Saturated Drain Efficiency	Pulsed ¹ , 2.5dB Gain Compression, 0.960 GHz 1.10 GHz 1.215 GHz	η_{SAT}	—	58.4 57.0 66.4	—	%
Saturated Output Power	Pulsed ¹ , 2.5dB Gain Compression, 0.960 GHz 1.10 GHz 1.215 GHz	P_{SAT}	—	65.0 63.9 63.9	—	dBm
Power Gain	Pulsed ¹ , $P_{OUT} = 63.0\text{ dBm}$, 0.960 GHz 1.10 GHz 1.215 GHz	G_P	—	17.5 16.9 16.6	—	dB
Drain Efficiency	Pulsed ¹ , $P_{OUT} = 63.0\text{ dBm}$, 0.960 GHz 1.10 GHz 1.215 GHz	η	—	50.0 52.5 61.0	—	%
Input Return Loss	Pulsed ¹ , $P_{OUT} = 63.0\text{ dBm}$, 0.960 GHz 1.10 GHz 1.215 GHz	IRL	—	- 5.7 - 5.5 - 4.7	—	dB
Gain Flatness	Pulsed ¹ , $P_{OUT} = 63.0\text{ dBm}$, 0.960- 1.215 GHz	ΔG	—	+/- 0.4	—	dB
Phase Variation	Pulsed ¹ , $P_{OUT} = 63.0\text{ dBm}$, 0.960- 1.215 GHz	$\Delta\phi$	—	+/- 15	—	Deg
Ruggedness: Output Mismatch	All phase angles	Ψ	VSWR = 10:1, No Damage			

**RF Electrical Specifications: $T_A = 25^\circ\text{C}$, $V_{DS} = 80\text{ V}$, $I_{DQ} = 400\text{ mA}$,
Note: Performance in MACOM Production Test Fixture, 50 Ω system**

Parameter	Test Conditions	Symbol	Min.	Typ.	Max.	Units
Power Gain	Pulsed ¹ , $P_{IN} = 48.0\text{ dBm}$, 0.960 GHz, 1.10 GHz, 1.215 GHz	G_P	—	15.5 15.6 15.0	—	dB
Gain Flatness	Pulsed ¹ , $P_{IN} = 35.0\text{ dBm}$, 0.960 - 1.215 GHz	ΔG	—	+/- 0.6	—	dB
Drain Efficiency	Pulsed ¹ , $P_{IN} = 48.0\text{ dBm}$, 0.960 GHz, 1.10 GHz, 1.215 GHz	η	—	56.5 56.8 63.9	—	%
Input Return Loss	Pulsed ¹ , $P_{IN} = 46.6\text{ dBm}$, 0.960 GHz, 1.10 GHz, 1.215 GHz	IRL	—	- 4.5 - 4.5 - 4.5	—	dB

1. Pulse details: 100 μs pulse width, 1% duty cycle.

2

MACOM Technology Solutions Inc. (MACOM) and its affiliates reserve the right to make changes to the product(s) or information contained herein without notice.
Visit www.macom.com for additional data sheets and product information.

For further information and support please visit:
<https://www.macom.com/support>

DC-0027961

Absolute Maximum Ratings^{2,3,4,5,6}

Parameter	Absolute Maximum
Output Power, P _{OUT}	66 dBm
Drain Source Voltage, V _{DS}	120 V
Storage Temperature Range	-40°C to +150°C
Case Operating Temperature Range	-40°C to +85°C
Channel Operating Temperature Range, T _{CH}	-40°C to +225°C
Absolute Maximum Channel Temperature	+250°C

2. Exceeding any one or combination of these limits may cause permanent damage to this device.
3. MACOM does not recommend sustained operation above maximum operating conditions.
4. Operating at drain source voltage $V_{DS} \leq 120V$ will ensure $MTTF > 2 \times 10^6$ hours.
5. Operating at nominal conditions with $T_{CH} \leq 225^\circ C$ will ensure $MTTF > 2 \times 10^6$ hours.
6. MTTF may be estimated by the expression $MTTF \text{ (hours)} = A e^{[B + C/(T+273)]}$ where T is the channel temperature in degrees Celsius, $A = 1$, $B = -38.215$, and $C = 26,343$.

RF Output Stage Thermal Characteristics⁷

Parameter	Test Conditions	Symbol	Typical	Units
Thermal Resistance using Finite Element Analysis	$V_{DS} = 120 V$, $T_C = 85^\circ C$, $T_{CH} = 225^\circ C$	R _θ (FEA)	0.057	°C/W
Thermal Resistance using Infrared Measurement of Die Surface Temperature	$V_{DS} = 120 V$, $T_C = 85^\circ C$, $T_{CH} = 225^\circ C$	R _θ (IR)	0.057	°C/W

7. Case temperature measured using thermocouple embedded in heat-sink. Contact local applications support team for more details on this measurement.

Handling Procedures

Please observe the following precautions to avoid damage:

Static Sensitivity

Gallium Nitride Circuits are sensitive to electrostatic discharge (ESD) and can be damaged by static electricity. Proper ESD control techniques should be used when handling these devices.

Typical Performance Curves:
Pulsed¹, $V_{DS} = 80\text{ V}$, $I_{DQ} = 400\text{ mA}$, $T_C = 25^\circ\text{C}$ (Unless Otherwise Noted)

Gain vs. Output Power and Frequency

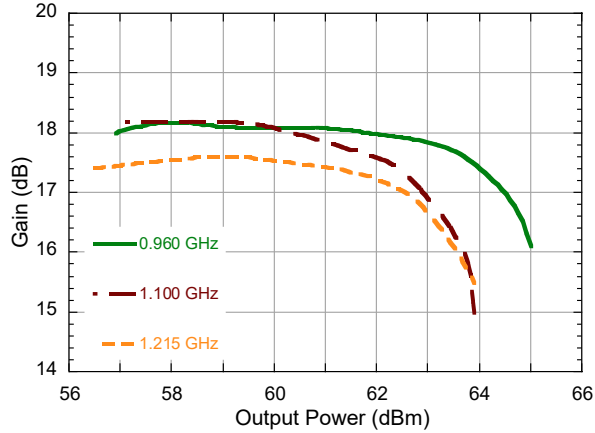

Drain Efficiency vs. Output Power and Frequency

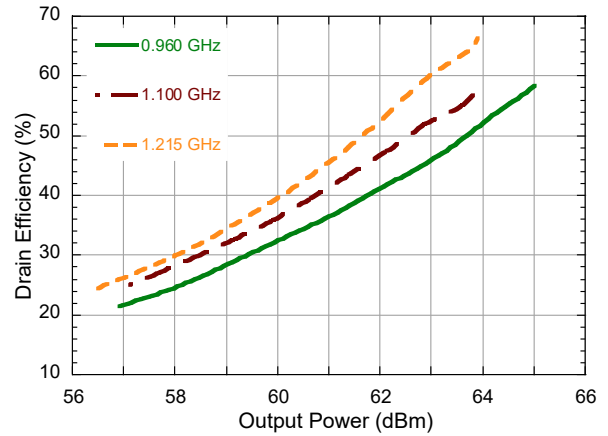

Gain vs. Frequency, $P_{in} = 46.6\text{ dBm}$

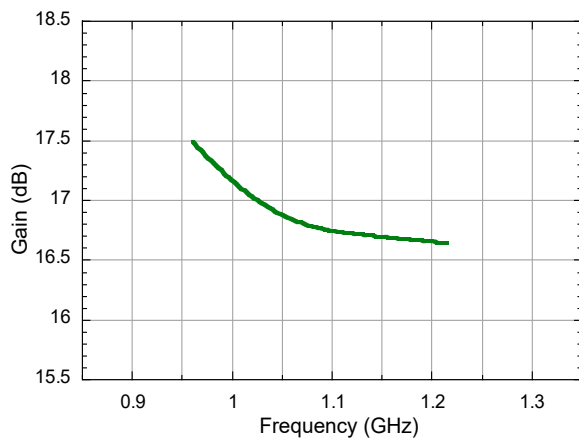

Drain Efficiency vs. Frequency, $P_{in} = 46.6\text{ dBm}$

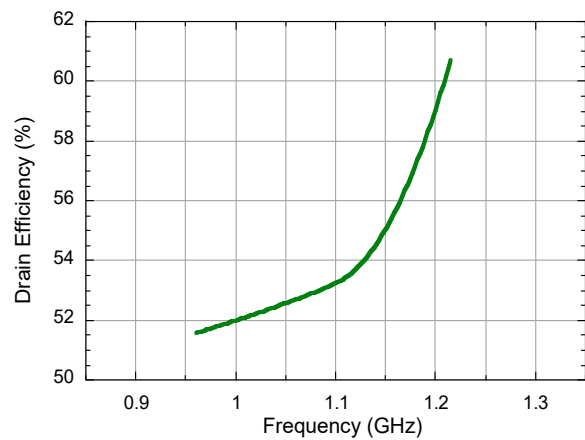

Outline Drawing

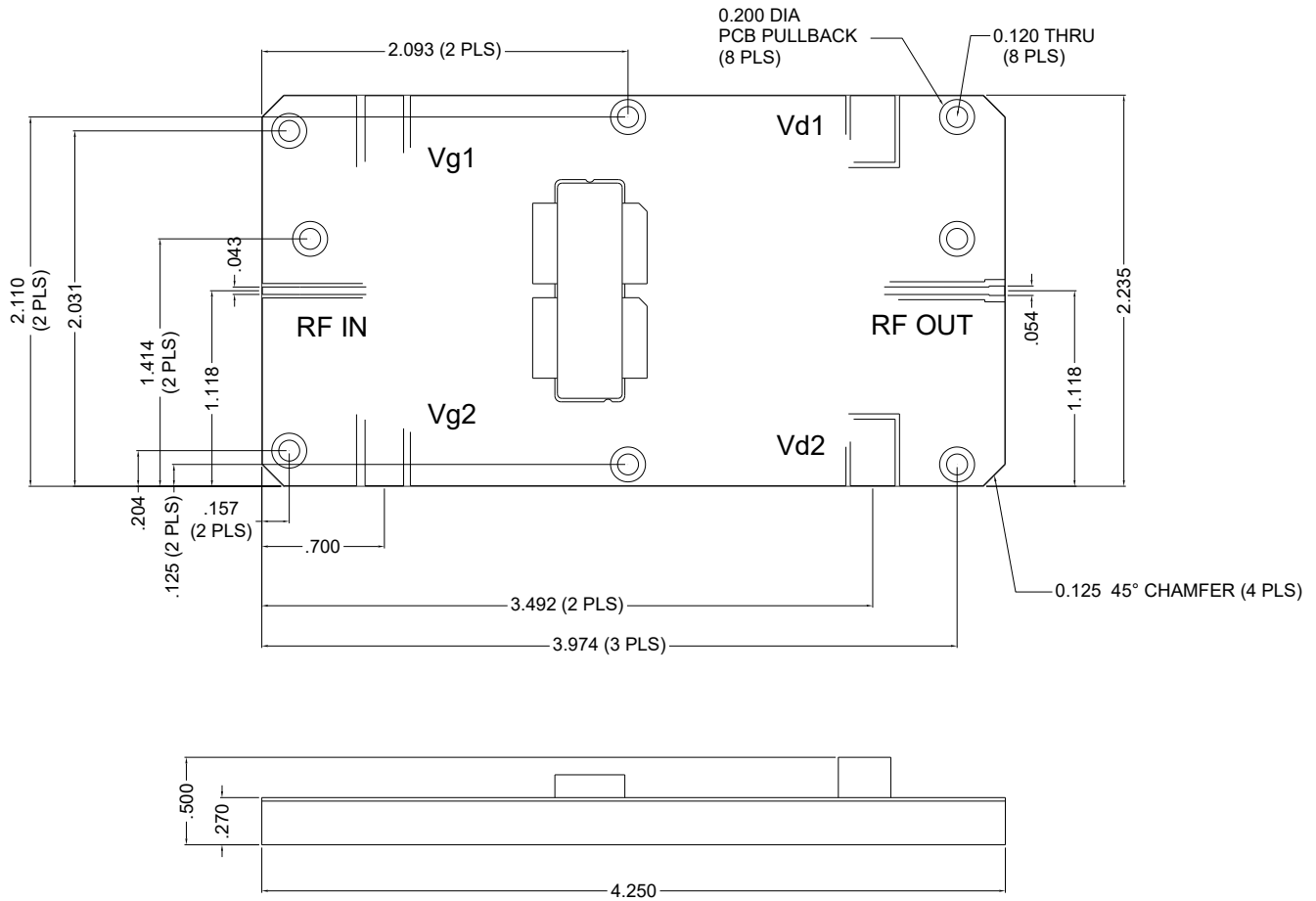

MACOM Technology Solutions Inc. ("MACOM"). All rights reserved.

These materials are provided in connection with MACOM's products as a service to its customers and may be used for informational purposes only. Except as provided in its Terms and Conditions of Sale or any separate agreement, MACOM assumes no liability or responsibility whatsoever, including for (i) errors or omissions in these materials; (ii) failure to update these materials; or (iii) conflicts or incompatibilities arising from future changes to specifications and product descriptions, which MACOM may make at any time, without notice. These materials grant no license, express or implied, to any intellectual property rights.

THESE MATERIALS ARE PROVIDED "AS IS" WITH NO WARRANTY OR LIABILITY, EXPRESS OR IMPLIED, RELATING TO SALE AND/OR USE OF MACOM PRODUCTS INCLUDING FITNESS FOR A PARTICULAR PURPOSE, MERCHANTABILITY, INFRINGEMENT OF INTELLECTUAL PROPERTY RIGHT, ACCURACY OR COMPLETENESS, OR SPECIAL, INDIRECT, INCIDENTAL, OR CONSEQUENTIAL DAMAGES WHICH MAY RESULT FROM USE OF THESE MATERIALS.

MACOM products are not intended for use in medical, lifesaving or life sustaining applications. MACOM customers using or selling MACOM products for use in such applications do so at their own risk and agree to fully indemnify MACOM for any damages resulting from such improper use or sale.