

### Features

- MACOM PURE CARBIDE™ Amplifier Series
- Suitable for Linear & Saturated Applications
- Pulsed Operation: 1250 W Output Power
- Internally Pre-Matched
- 260°C Reflow Compatible
- 50 V Operation
- 100% RF Tested
- RoHS\* Compliant

### Applications

- UHF Radar, Public Safety Radio.

### Description

The MAPC-A1502 is a high power GaN on Silicon Carbide HEMT D-mode amplifier suitable for 400 - 460 MHz frequency operation. The device supports pulsed operation with output power levels of 1250 W (61 dBm) at 50 V in an air cavity ceramic package.

### Typical Performance:

Measured in MACOM evaluation circuit at 3 dB compression, 15 mS pulse width, 25% duty cycle.

- $V_{DS} = 50\text{ V}$ ,  $I_{DQ} = 600\text{ mA}$ ,  $T_C = 25^\circ\text{C}$ .

Frequency (MHz)	Output Power (dBm)	Gain (dB)	$\eta_D$ (%)
400	61.3	15.6	81.7
410	61.3	16.3	84.1
420	61.2	16.7	84.3
430	61.1	16.7	83.2
440	61.2	16.6	83.8
450	61.3	16.1	83.0
460	61.2	15.4	81.6

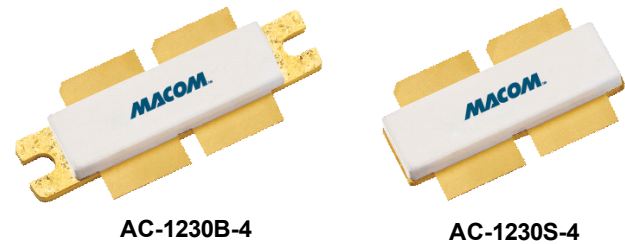

### Functional Schematic

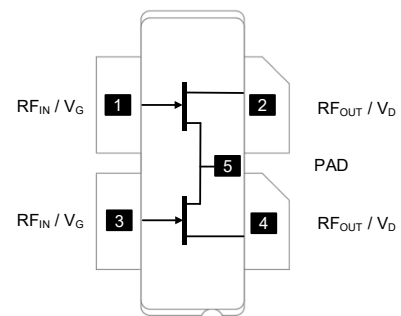

### Pin Configuration

Pin #	Pin Name	Function
1, 3	RF <sub>IN</sub> / V <sub>G</sub>	RF Input / Gate
2, 4	RF <sub>OUT</sub> / V <sub>D</sub>	RF Output / Drain
5	Flange <sup>1</sup>	Ground / Source

1. The flange on the package bottom must be connected to RF, DC and thermal ground.

### Ordering Information

Part Number	Package
MAPC-A1502-AS000	Bulk Quantity : Earless
MAPC-A1502-ASTR1	Tape and Reel : Earless
MAPC-A1502-ASSB1	Sample Board : Earless
MAPC-A1502-AB000	Bulk Quantity : Boltdown
MAPC-A1502-ABTR1	Tape and Reel : Boltdown
MAPC-A1502-ABSB1	Sample Board : Boltdown

\* Restrictions on Hazardous Substances, compliant to current RoHS EU directive.

**RF Electrical Characteristics:  $T_C = 25^\circ\text{C}$ ,  $V_{DS} = 50\text{ V}$ ,  $I_{DQ} = 600\text{ mA}$**   
**Note: Performance in MACOM 400-460 MHz Evaluation Test Fixture, 50  $\Omega$  system**

Parameter	Test Conditions	Symbol	Min.	Typ.	Max.	Units
Small Signal Gain	Pulsed <sup>2</sup> , 430 MHz	$G_{SS}$	-	19.7	-	dB
Saturated Output Power	Pulsed <sup>2</sup> , 430 MHz, 3 dB Gain Compression	$P_{SAT}$	-	61.1	-	dBm
Power Gain	Pulsed <sup>2</sup> , 430 MHz, 3 dB Gain Compression	$G_{SAT}$	-	16.7	-	dB
Saturated Drain Efficiency	Pulsed <sup>2</sup> , 430 MHz, 3 dB Gain Compression	$\eta_{SAT}$	-	83.2	-	%
Gain Variation (-40°C to +85°C)	Pulsed <sup>2</sup> , 430 MHz	$\Delta G$	-	0.011	-	dB/°C
Power Variation (-40°C to +85°C)	Pulsed <sup>2</sup> , 430 MHz	$\Delta P_{3dB}$	-	0.003	-	dB/°C
Power Gain	Pulsed <sup>2</sup> , 430 MHz, $P_{IN} = 43.1\text{ dBm}$	$G_P$	-	61	-	dB
Drain Efficiency	Pulsed <sup>2</sup> , 430 MHz, $P_{IN} = 43.1\text{ dBm}$	$\eta$	-	82.1	-	%
Input Return Loss	Pulsed <sup>2</sup> , 430 MHz, $P_{IN} = 43.1\text{ dBm}$	IRL	-	-17	-	dB
Ruggedness: Output Mismatch	Pulsed <sup>3</sup> , All phase angles	$\Psi$	VSWR = 50:1, No Damage			

**RF Electrical Specifications:  $T_A = 25^\circ\text{C}$ ,  $V_{DS} = 50\text{ V}$ ,  $I_{DQ} = 600\text{ mA}$**   
**Note: Performance in MACOM 400 MHz Production Test Fixture, 50  $\Omega$  system**

Parameter	Test Conditions	Symbol	Min.	Typ.	Max.	Units
Power Gain	Pulsed <sup>3</sup> , 400 MHz, 2.5 dB Gain Compression	$G_{SAT}$	15.0	16.6	-	dB
Saturated Drain Efficiency	Pulsed <sup>3</sup> , 400 MHz, 2.5 dB Gain Compression	$\eta_{SAT}$	72.2	78.2	-	%
Saturated Output Power	Pulsed <sup>3</sup> , 400 MHz, 2.5 dB Gain Compression	$P_{SAT}$	60.4	61.2	-	dBm

**DC Electrical Characteristics  $T_A = 25^\circ\text{C}$**

Parameter	Test Conditions	Symbol	Min.	Typ.	Max.	Units
Drain-Source Leakage Current	$V_{GS} = -8\text{ V}$ , $V_{DS} = 130\text{ V}$	$I_{DLK}$	-	-	215	mA
Gate-Source Leakage Current	$V_{GS} = -8\text{ V}$ , $V_{DS} = 0\text{ V}$	$I_{GLK}$	-	-	215	mA
Gate Threshold Voltage	$V_{DS} = 50\text{ V}$ , $I_D = 215\text{ mA}$	$V_T$	-	-2.9	-	V
Gate Quiescent Voltage	$V_{DS} = 50\text{ V}$ , $I_D = 600\text{ mA}$	$V_{GSQ}$	-	-2.71	-	V
Maximum Drain Current	$V_{DS} = 7\text{ V}$ pulsed, pulse width 300 $\mu\text{s}$	$I_{D, MAX}$	-	255	-	A

2. Pulse Details: 15 mS pulse width, 25% duty cycle.  
3. Pulse Details: 100  $\mu\text{s}$  pulse width, 10% duty cycle.

### Absolute Maximum Ratings<sup>4,5,6,7,8</sup>

Parameter	Absolute Maximum
Drain Source Voltage, $V_{DS}$	130 V
Gate Source Voltage, $V_{GS}$	-10 to 3 V
Gate Current, $I_G$	215 mA
Storage Temperature Range	-65°C to +150°C
Case Operating Temperature Range	-40°C to +85°C
Channel Operating Temperature Range, $T_{CH}$	-40°C to +225°C
Absolute Maximum Channel Temperature	+250°C

4. Exceeding any one or combination of these limits may cause permanent damage to this device.
5. MACOM does not recommend sustained operation near these survivability limits.
6. Operating at drain source voltage  $V_{DS} < 55$  V will ensure  $MTTF > 2 \times 10^6$  hours.
7. Operating at nominal conditions with  $T_{CH} \leq 200^\circ\text{C}$  will ensure  $MTTF > 2 \times 10^6$  hours.
8.  $MTTF$  may be estimated by the expression  $MTTF$  (hours) =  $A e^{\frac{B+C}{T+273}}$  where  $T$  is the channel temperature in degrees Celsius,  $A = 1$ ,  $B = -38.215$ , and  $C = 26,343$ .

### Thermal Characteristics<sup>9</sup>

Parameter	Test Conditions	Symbol	Typical	Units
Thermal Resistance using Finite Element Analysis	$V_{DS} = 50$ V $T_C = 85^\circ\text{C}, T_{CH} = 225^\circ\text{C}$	$R_{\theta}(\text{FEA})$	0.19	$^\circ\text{C/W}$
Thermal Resistance using Infrared Measurement of Die Surface Temperature	$V_{DS} = 50$ V $T_C = 85^\circ\text{C}, T_{CH} = 225^\circ\text{C}$	$R_{\theta}(\text{IR})$	0.152	$^\circ\text{C/W}$

9. Case temperature measured using thermocouple embedded in heat-sink. Contact local applications support team for more details on this measurement.

### Handling Procedures

Please observe the following precautions to avoid damage:

### Static Sensitivity

Gallium Nitride Circuits are sensitive to electrostatic discharge (ESD) and can be damaged by static electricity. Proper ESD control techniques should be used when handling these devices.

**Evaluation Test Fixture and Recommended Tuning Solution 400 - 460 MHz**

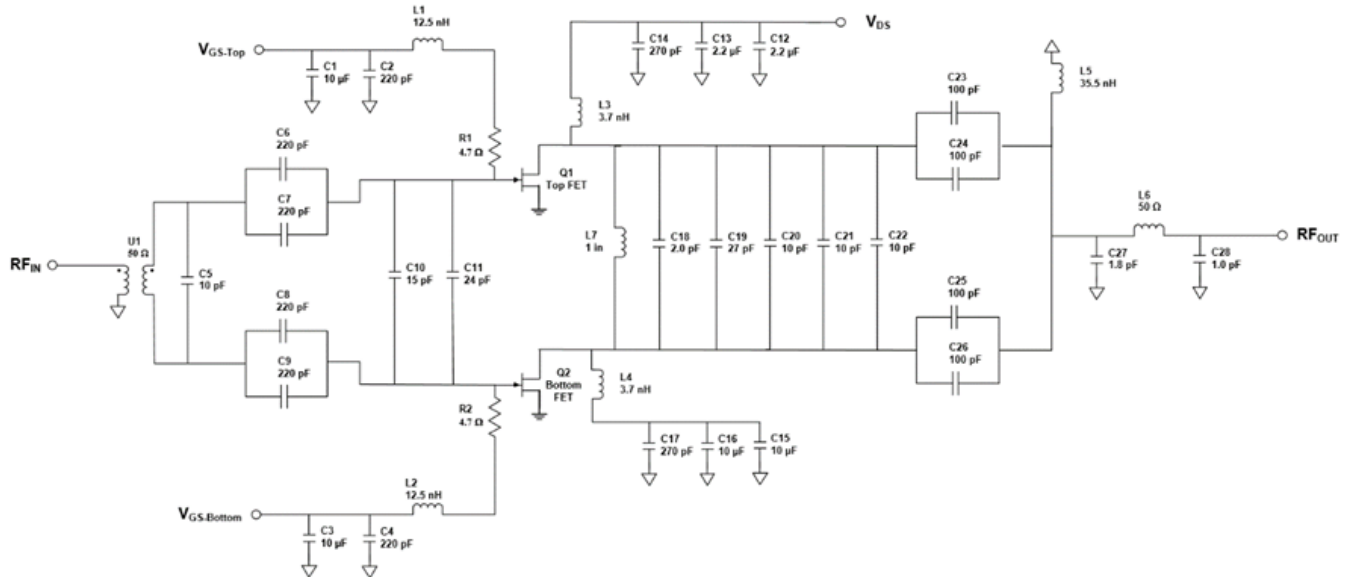

**Description**

Parts measured on evaluation board (50-mil thick RO3006). Matching is provided using a combination of lumped elements and transmission lines as shown in the simplified schematic above. Recommended tuning solution component placement, transmission lines, and details are shown on the next page.

**Bias Sequencing**

**Turning the device ON**

1. Set  $V_{GS}$  to pinch-off ( $V_P$ ).
2. Turn on  $V_{DS}$  to nominal voltage (50 V).
3. Increase  $V_{GS}$  until  $I_{DS}$  current is reached.
4. Apply RF power to desired level.

**Turning the device OFF**

1. Turn the RF power OFF.
2. Decrease  $V_{GS}$  down to  $V_P$  pinch-off.
3. Decrease  $V_{DS}$  down to 0 V.
4. Turn off  $V_{GS}$ .

Evaluation Test Fixture and Recommended Tuning Solution 400 - 460 MHz

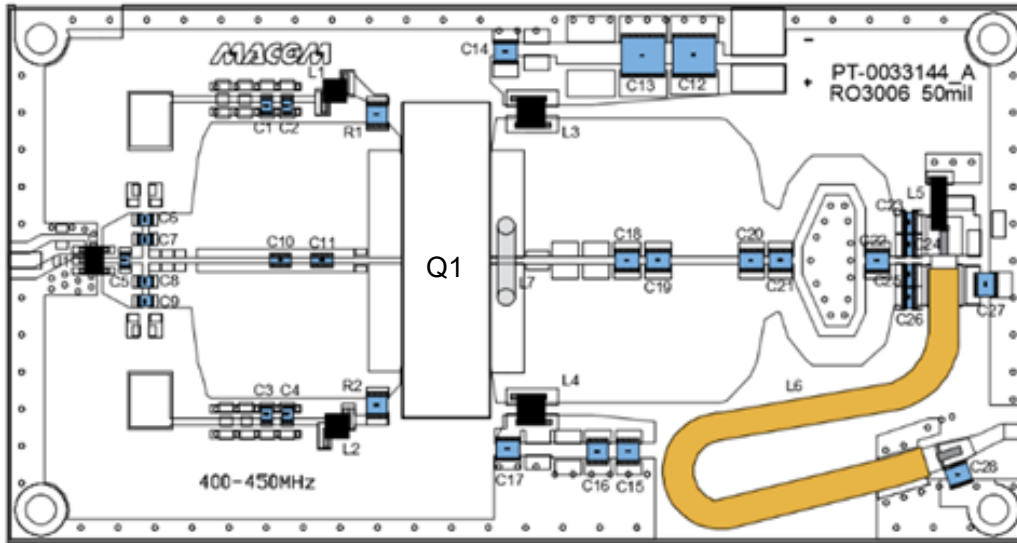

Reference Designator	Value	Tolerance	Manufacturer	Part Number
C1, C3	10 $\mu$ f	+/- 10 %	Murata	GRM21BR6YA106KE43L
C2, C4, C6-C9	220 pF	+/- 5 %	PPI	0805N221JW251X
C5	10 pF	+/- 5 %	PPI	0805N100JW251X
C10	15 pF	+/- 5 %	PPI	0708N150JW501
C11	24 pF	+/- 5 %	PPI	0708N240JW501
C12, C13	2.2 $\mu$ F	+/- 20 %	Murata	KRM55TR72E225MH01L
C14, C17	270 pF	+/- 5 %	PPI	1111N271JW201X
C15, C16	10 $\mu$ F	+/- 10 %	Murata	GRM32EC72A106KE05L
C18	2.0 pF	+/- 0.1 pF	PPI	1111N2R0BW501X
C19	27 pF	+/- 5 %	PPI	1111N270JW501X
C20-C22	10 pF	+/- 5 %	PPI	1111N100JW501X
C23-C26	100 pF	+/- 5 %	PPI	0708N101JW501
C27	1.8 pF	+/- 0.1 pF	PPI	1111N1R8BW501X
C28	1.0 pF	+/- 0.1 pF	PPI	1111N1R0BW501X
R1, R2	4.7 $\Omega$	+/- 5 %	KOA Speer	SG73P2ETTD4R7J
L1, L2	12.5 nH	+/- 5 %	Coilcraft	A04TJLC
L3, L4	3.7 nH	+/- 5 %	Coilcraft	GA3092-ALC
L5	35.5 nH	+/- 2 %	Coilcraft	B09TGLB
L6	50 $\Omega$	-	AMAWAVE	UT-141C
L7	1 in	-	-	18 AWG
U1	50 $\Omega$	-	Macom	MABA-009602-ES2922
Q1	MACOM GaN Power Amplifier			MAPC-A1502
PCB	RO3006, 50 mil, 1.0 oz. Cu, Au Finish			

Typical Performance Curves as Measured in the 400 - 460 MHz Evaluation Test Fixture:  
Pulsed<sup>2</sup> 430 MHz,  $V_{DS} = 50$  V,  $I_{DQ} = 600$  mA,  $T_C = 25^\circ\text{C}$  (Unless Otherwise Noted)

Gain vs. Output Power and Frequency

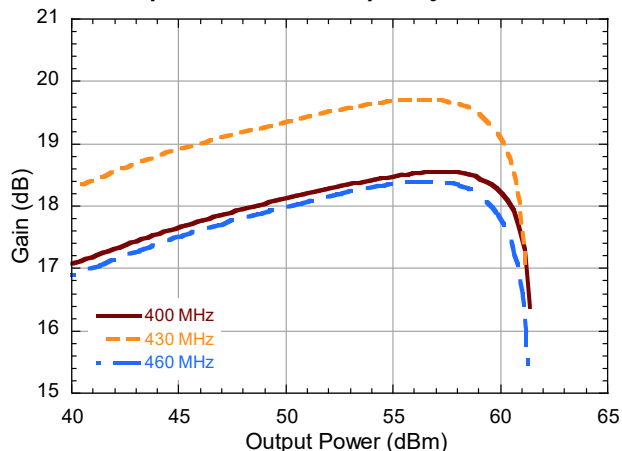

Drain Efficiency vs. Output Power and Frequency

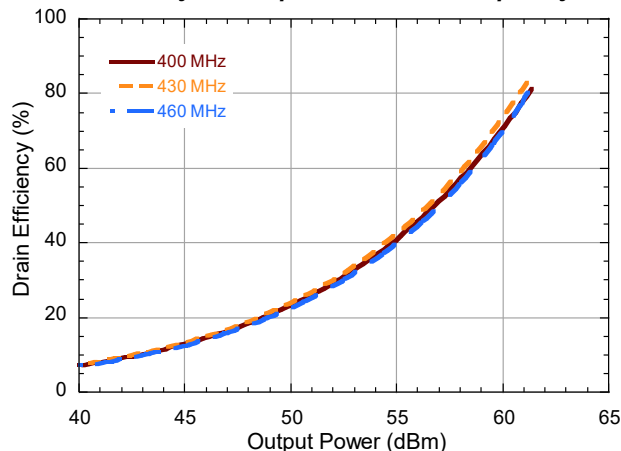

Gain vs. Output Power and  $V_{DS}$

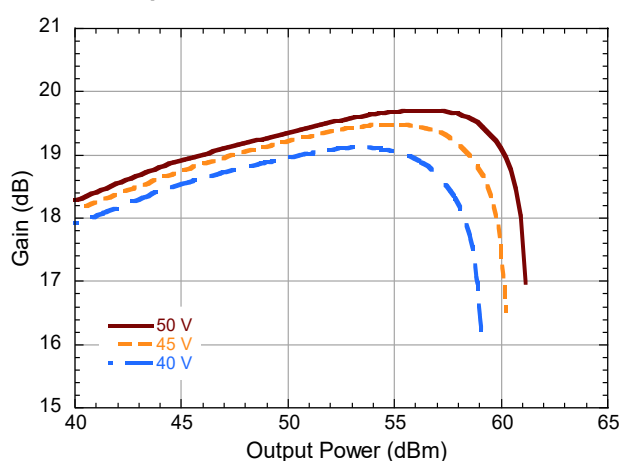

Drain Efficiency vs. Output Power and  $V_{DS}$

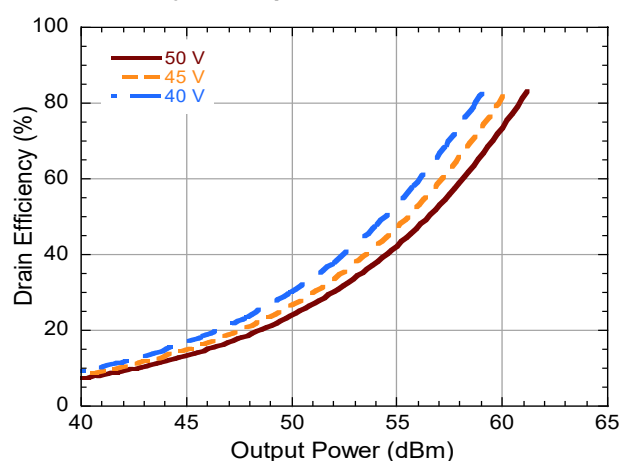

Gain vs. Output Power and  $I_{DQ}$

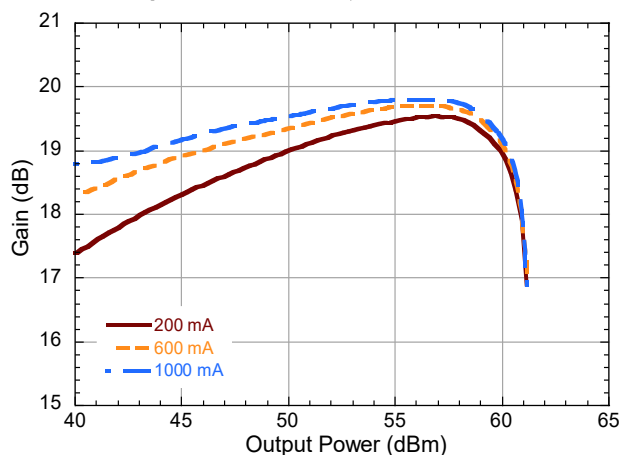

Drain Efficiency vs. Output Power and  $I_{DQ}$

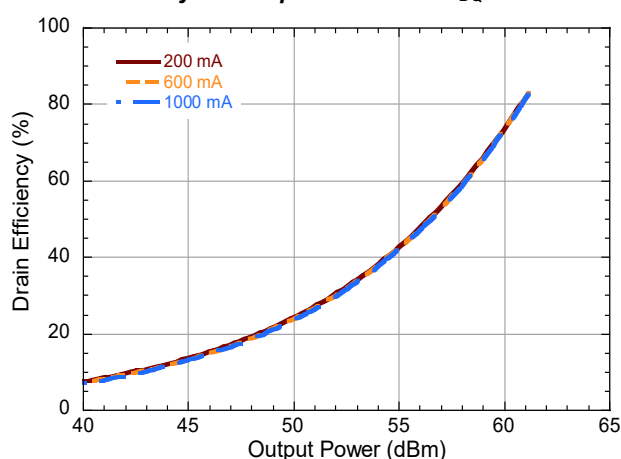

Typical Performance Curves as Measured in the 400 - 460 MHz Evaluation Test Fixture:  
Pulsed<sup>2</sup> 430 MHz,  $V_{DS} = 50\text{ V}$ ,  $I_{DQ} = 600\text{ mA}$ ,  $T_C = 25^\circ\text{C}$  (Unless Otherwise Noted)

**Gain vs. Output Power and  $T_C$**

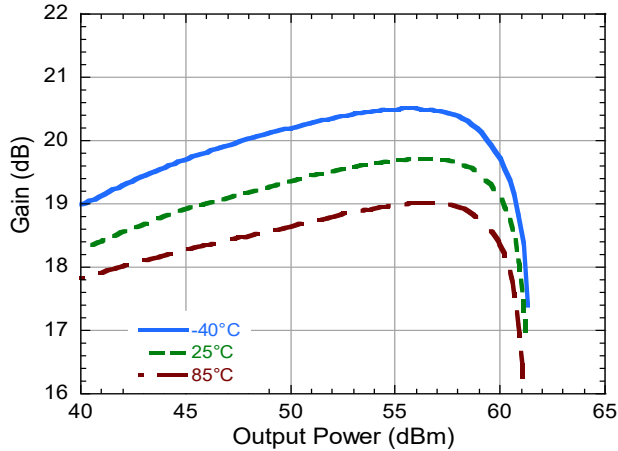

**Drain Efficiency vs. Output Power and  $T_C$**

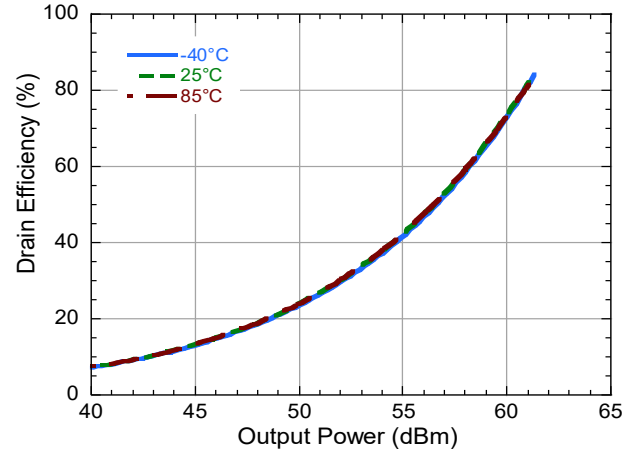

**Gain vs. Frequency, 3dB Compression**

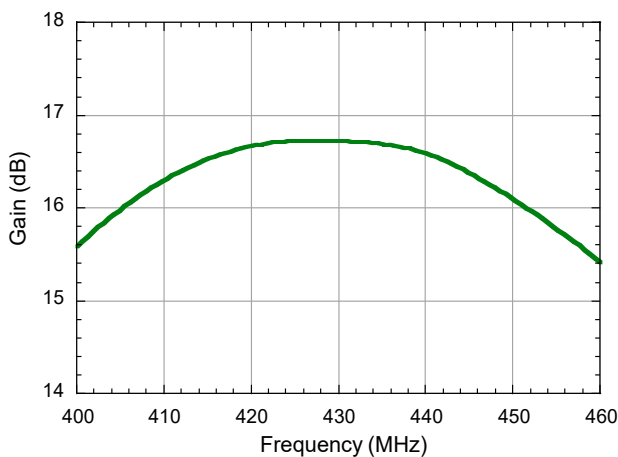

**Drain Efficiency vs. Frequency, 3dB Compression**

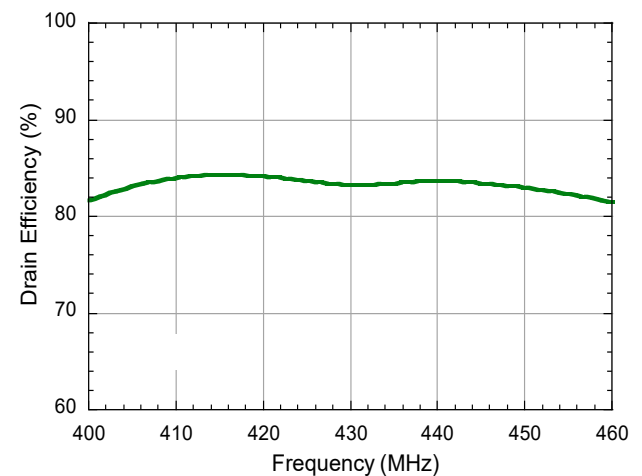

**Output Power vs. Frequency, 3dB Compression**

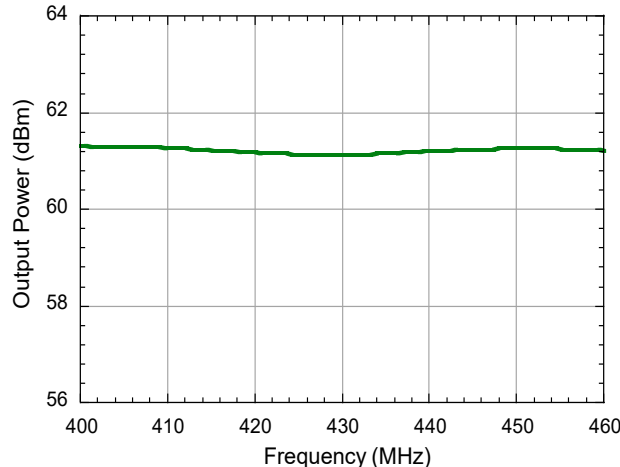

**Lead-Free AC-1230S-4 Package Dimensions<sup>†</sup>**

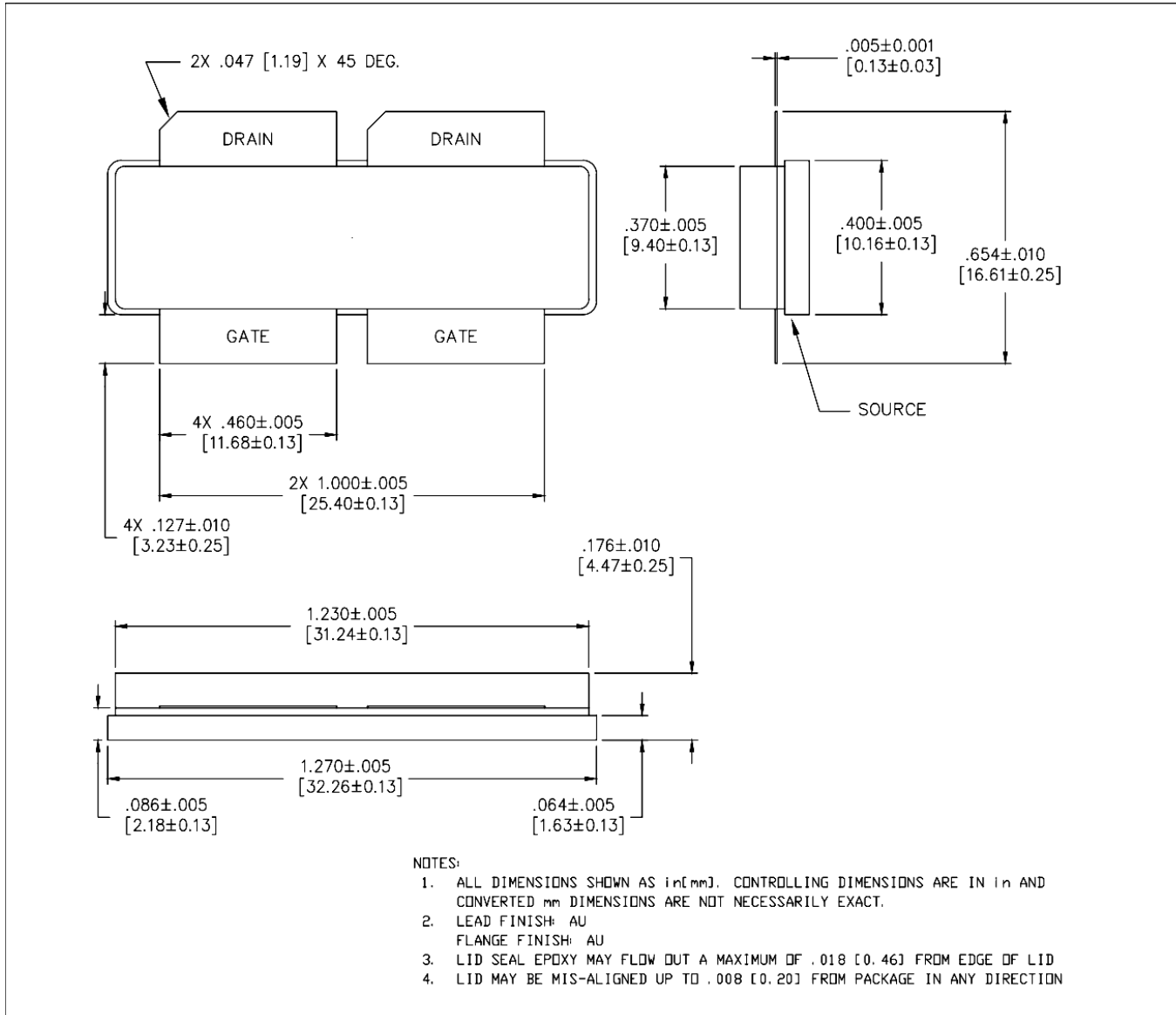

<sup>†</sup> Reference Application Note AN0004363 for lead-free solder reflow recommendations.  
Meets JEDEC moisture sensitivity level 3 requirements.  
Plating is Au.



Lead-Free AC-1230B-4 Package Dimensions<sup>†</sup>

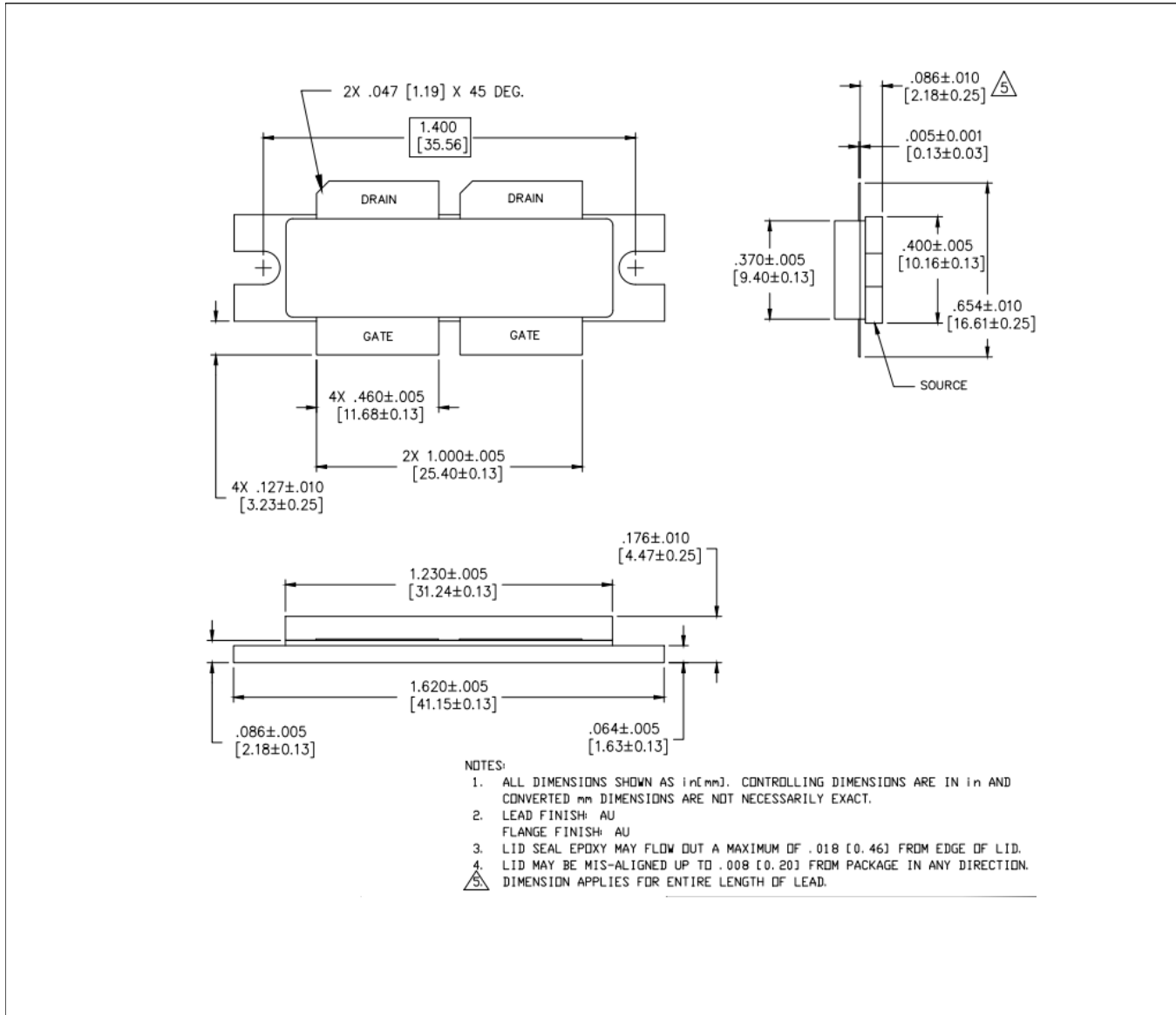

<sup>†</sup> Reference Application Note AN0004363 for lead-free solder reflow recommendations.  
Meets JEDEC moisture sensitivity level 3 requirements.  
Plating is Au.

MACOM Technology Solutions Inc. ("MACOM"). All rights reserved.

These materials are provided in connection with MACOM's products as a service to its customers and may be used for informational purposes only. Except as provided in its Terms and Conditions of Sale or any separate agreement, MACOM assumes no liability or responsibility whatsoever, including for (i) errors or omissions in these materials; (ii) failure to update these materials; or (iii) conflicts or incompatibilities arising from future changes to specifications and product descriptions, which MACOM may make at any time, without notice. These materials grant no license, express or implied, to any intellectual property rights.

THESE MATERIALS ARE PROVIDED "AS IS" WITH NO WARRANTY OR LIABILITY, EXPRESS OR IMPLIED, RELATING TO SALE AND/OR USE OF MACOM PRODUCTS INCLUDING FITNESS FOR A PARTICULAR PURPOSE, MERCHANTABILITY, INFRINGEMENT OF INTELLECTUAL PROPERTY RIGHT, ACCURACY OR COMPLETENESS, OR SPECIAL, INDIRECT, INCIDENTAL, OR CONSEQUENTIAL DAMAGES WHICH MAY RESULT FROM USE OF THESE MATERIALS.

MACOM products are not intended for use in medical, lifesaving or life sustaining applications. MACOM customers using or selling MACOM products for use in such applications do so at their own risk and agree to fully indemnify MACOM for any damages resulting from such improper use or sale.