

Double-Balanced Mixer

17 - 31 GHz



MAMX-011126

Rev. V1

Features

- Low Conversion Loss: 8.5 dB
- LO Drive Level: +7 dBm
- IIP3: +14 dBm
- Wide IF Bandwidth: DC to 8 GHz
- High Isolation
- Lead-Free 3 mm 12-lead AQFN package
- RoHS* Compliant

Applications

- Test & Measurement
- Microwave Radio & Radar
- Satellite Communications

Description

MAMX-011126 is a double-balanced passive diode mixer housed in a 3 mm, 12-lead AQFN package. The mixer offers low conversion loss, and a wide IF bandwidth. The double-balanced circuit configuration provides excellent port isolation while internal 50 Ω matching simplifies its application.

This mixer is well suited for applications such as test and measurement, microwave radio, and satellite communications.

Ordering Information^{1,2}

Part Number	Package
MAMX-011126	Cut Tape or Tray
MAMX-011126-TR0100	100 Piece Reel
MAMX-011126-TR0500	500 Piece Reel
MAMX-011126-SMB	Sample Board

1. Reference Application Note M513 for reel size information.
2. All sample boards include 3 loose parts.

Functional Schematic

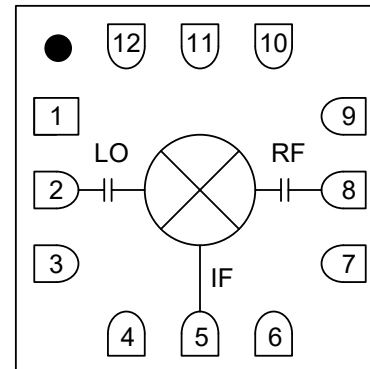

Pin Names

Pin #	Function
1,3,4,6,7,9	GND
2	LO
5	IF
8	RF
10 - 12	NC ³
13	GND ⁴

3. MACOM recommends connecting non connect or unused package pins to ground.
4. The exposed pad centered on the package bottom must be connected to RF, DC and thermal ground.

* Restrictions on Hazardous Substances, compliant to current RoHS EU directive.

Double-Balanced Mixer

17 - 31 GHz



MAMX-011126

Rev. V1

Pin Description

Pin #	Name	Description
1, 3, 4, 6, 7, 9	Ground	Ground Connection pads must be connected to ground.
2	LO	LO input matched and DC open, AC coupled.
5	IF	DC coupled to diodes and IF matched.
8	RF	RF matched and DC open, AC coupled.
10 - 12	Non connect	No internal connection. Recommended these pins are connected to ground.
13	Paddle	Package ground paddle and must be connected to RF and DC ground to ensure best possible RF performance.

Double-Balanced Mixer

17 - 31 GHz



MAMX-011126

Rev. V1

Electrical Specifications⁵: $P_{LO} = 7 \text{ dBm}$, $F_{IF} = 4 \text{ GHz}$, $T_A = 25^\circ\text{C}$, $Z_0 = 50 \Omega$

Parameter	Test Conditions	Units	Min.	Typ.	Max.
RF Frequency	—	GHz	17	—	31
LO Frequency	—	GHz	13	—	24
IF Frequency	—	GHz	0	—	8
LO Power	—	dBm	5	7	12
Conversion Loss	17 - 21 GHz	dB	—	9.5	11
	21 - 25 GHz			8.5	10
	25 - 31 GHz			7.5	9
Input P1dB	17 - 31 GHz	dBm	—	6	—
Input IP3	$P_{RF} = -10 \text{ dBm/tone}$, $\Delta f = 1 \text{ MHz}$	dBm	—	14	—
Input IP2	$P_{RF} = -10 \text{ dBm/tone}$, $\Delta f = 1 \text{ MHz}$	dBm	—	38	—
LO-to-RF Isolation	13 - 24 GHz	dB	—	42	—
LO-to-IF Isolation	13 - 24 GHz	dB	—	38	—
RF-to-IF Isolation	17 - 31 GHz	dB	—	25	—
RF Return Loss	17 - 31 GHz	dB	—	8	—
LO Return Loss	13 - 24GHz	dB	—	8	—
IF Return Loss	IF = 4 GHz	dB	—	12	—

5. All specifications refer to down-conversion operation, unless otherwise noted.

Recommended Operating Conditions

Parameter	Minimum	Nominal	Maximum
LO Power	+5 dBm	+7 dBm	+12 dBm
RF/IF Power	—	-10 dBm	+6 dBm
Temperature	-55°C	+25°C	+100°C

Handling Procedures

Please observe the following precautions to avoid damage:

Static Sensitivity

These electronic devices are sensitive to electrostatic discharge (ESD) and can be damaged by static electricity. Proper ESD control techniques should be used when handling these devices. The ESD classification for this part is Class 1B HBM.

Absolute Maximum Ratings^{6,7}

Parameter	Absolute Maximum
LO Power	+18 dBm
RF or IF Power	+16 dBm
Junction Temperature ⁸	+150°C
Storage Temperature	-65°C to +150°C

- Exceeding any one or combination of these limits may cause permanent damage to this device.
- MACOM does not recommend sustained operation near these survivability limits.
- Operating at nominal conditions with $T_J \leq +150^\circ\text{C}$ will ensure $\text{MTTF} > 1 \times 10^6$ hours.

Double-Balanced Mixer

17 - 31 GHz



MAMX-011126

Rev. V1

MxN Spurious Rejection at IF Port (dBc IF)

RF = 27.5 GHz @ -10 dBm

LO = 23.5 GHz @ +7 dBm

mxRF	nxLO				
	0	1	2	3	4
0	X	29	40	X	X
1	31	0	31	47	X
2	X	80	55	50	X
3	X	X	X	66	66
4	X	X	X	X	91

PCB Layout

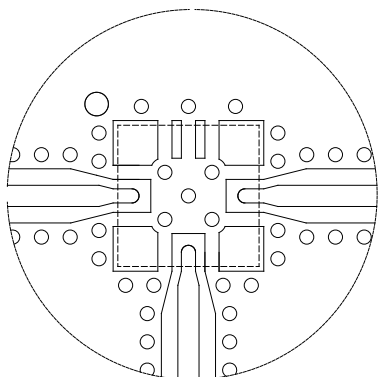

DXF/Gerber available on request based on 10 mil RO4350

Application Schematic

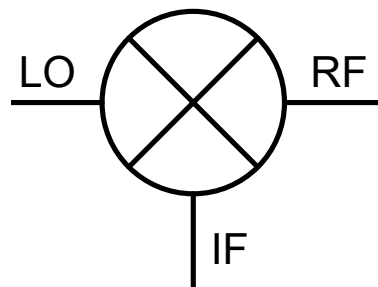

No external parts required for operation of MAMX-011126.

Evaluation Board

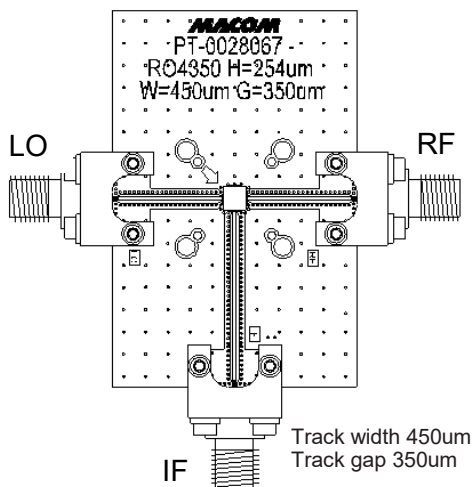

Evaluation Board Losses

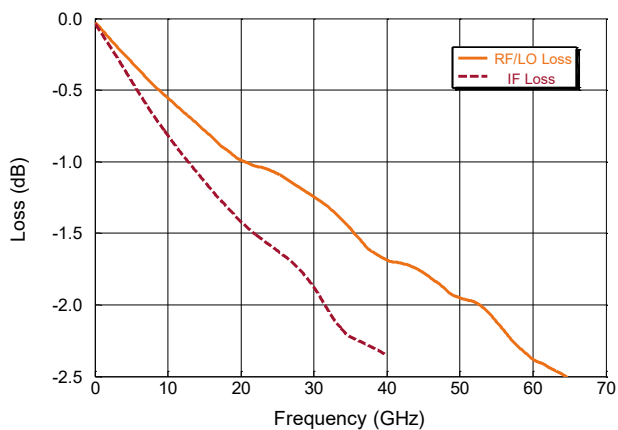

Double-Balanced Mixer

17 - 31 GHz



MAMX-011126

Rev. V1

Typical Performance Curves: Down Conversion Mode, Upper Side Band (USB), Low Side LO @ +25°C. $I_F = 4$ GHz

Conversion Loss vs. Frequency

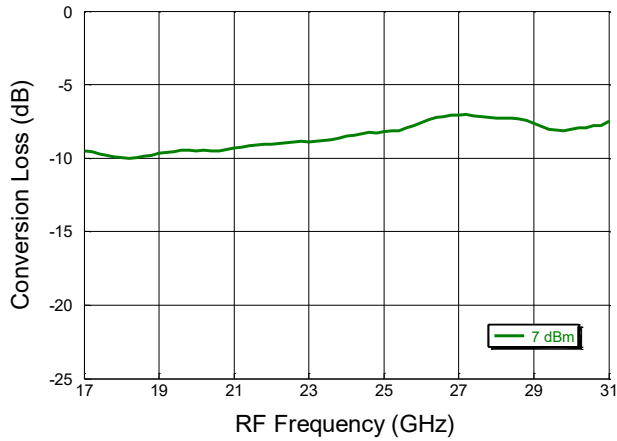

Conversion Loss over LO Drive

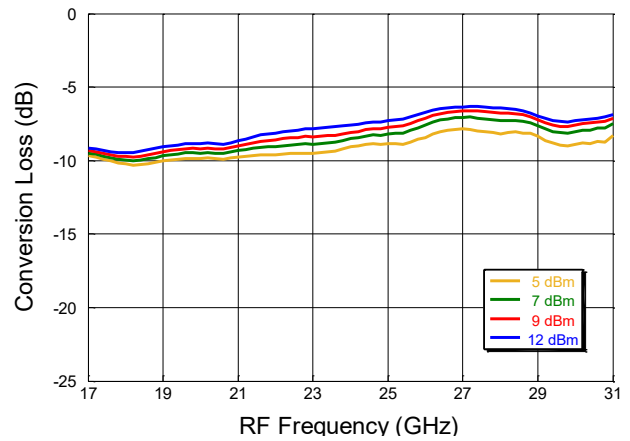

IIP3 over LO Drive vs. RF Frequency

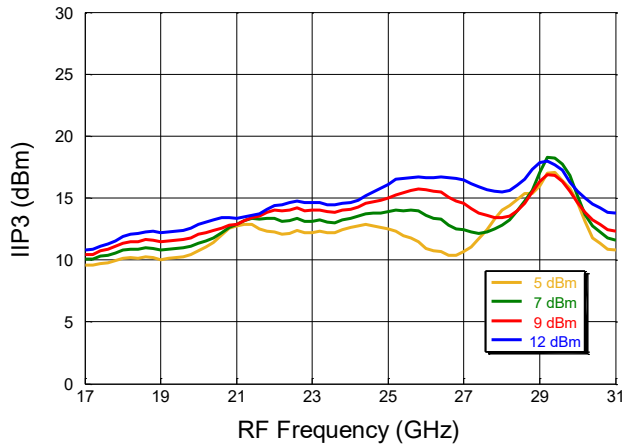

IIP2 over LO Drive vs. RF Frequency

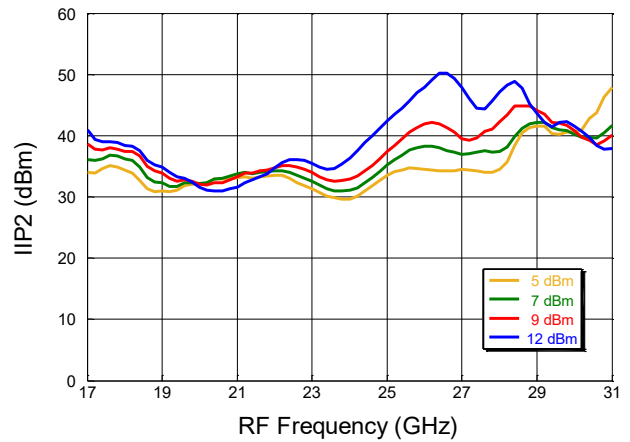

Double-Balanced Mixer

17 - 31 GHz



MAMX-011126

Rev. V1

Typical Performance Curves: Down Conversion Mode, Upper Side Band (USB), Over Temperature. $I_F = 4$ GHz and $P_{Lo} = 7$ dBm

Conversion Loss over Temperature

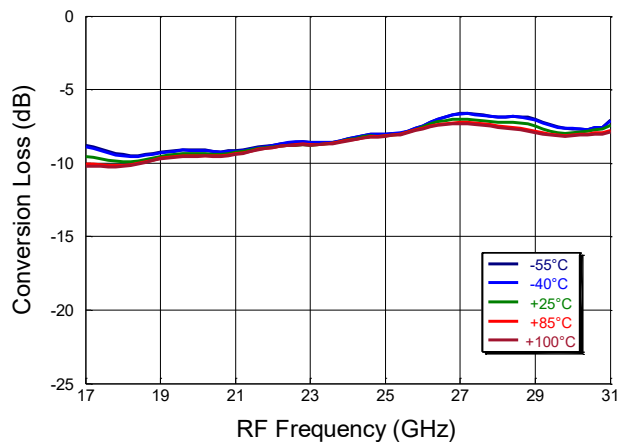

IIP2 over Temperature

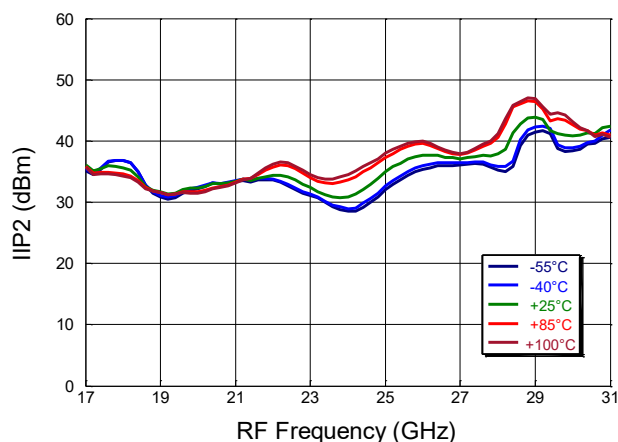

IIP3 over Temperature

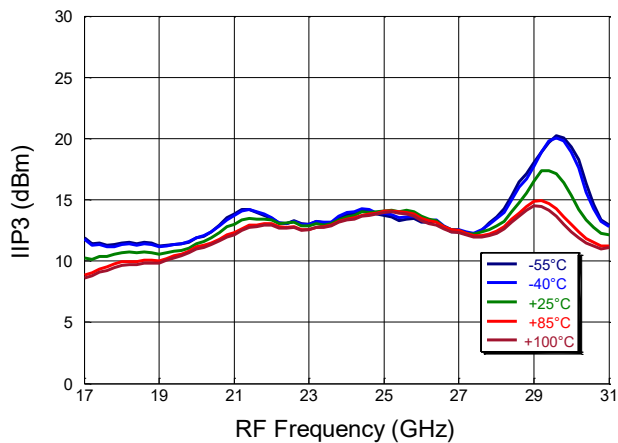

Double-Balanced Mixer

17 - 31 GHz



MAMX-011126

Rev. V1

Typical Performance Curves: Down Conversion Mode, Upper Side Band (USB), Low Side LO @ +25°C. $I_F = 1$ GHz

Conversion Loss vs. Frequency

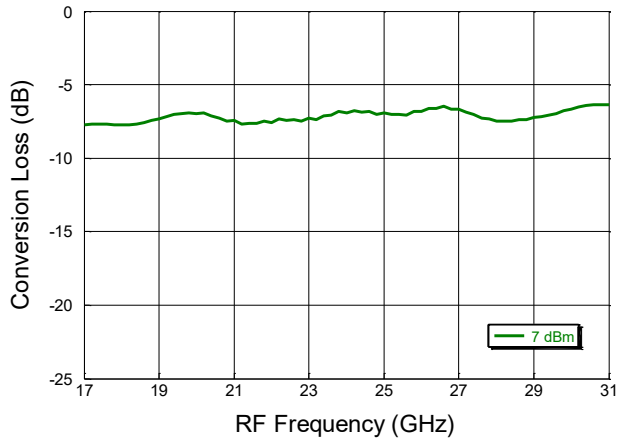

Conversion Loss over LO Drive

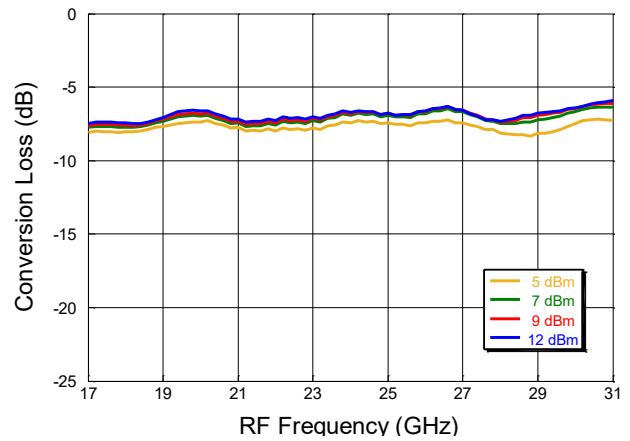

IIP3 over LO Drive vs. RF Frequency

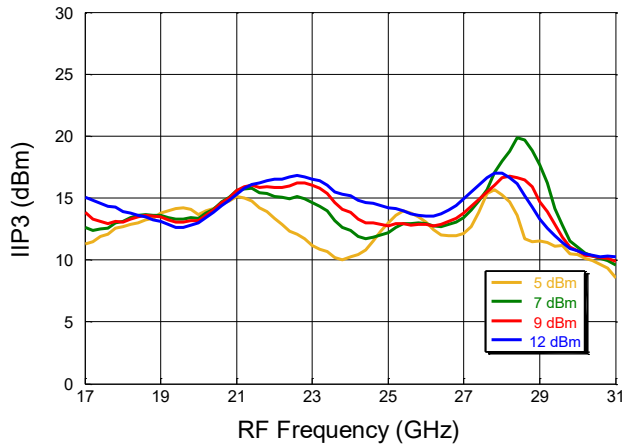

IIP2 over LO Drive vs. RF Frequency

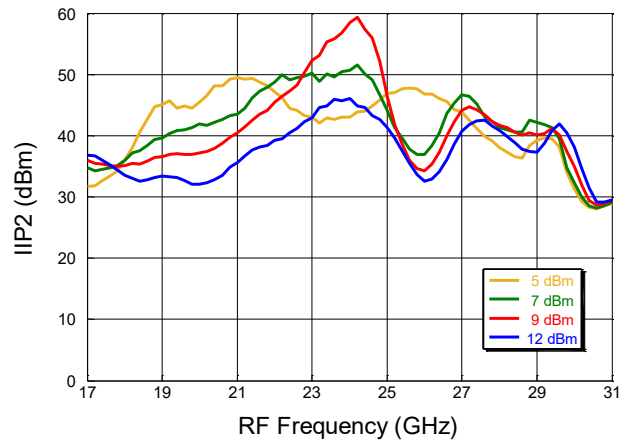

Double-Balanced Mixer

17 - 31 GHz



MAMX-011126

Rev. V1

Typical Performance Curves: Down Conversion Mode, Upper Side Band (USB), Low Side LO @ +25°C. IF = 6.5 GHz

Conversion Loss vs. Frequency

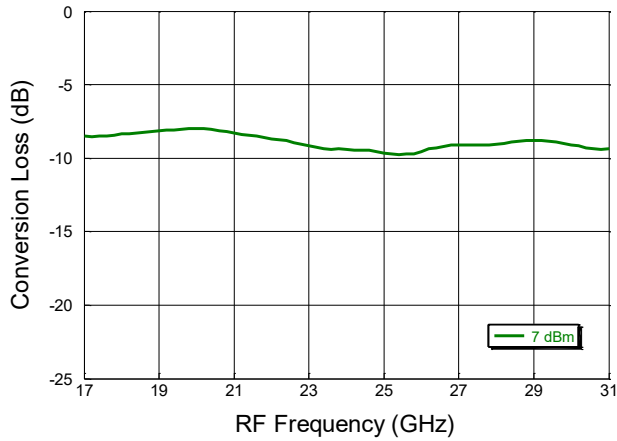

Conversion Loss over LO Drive

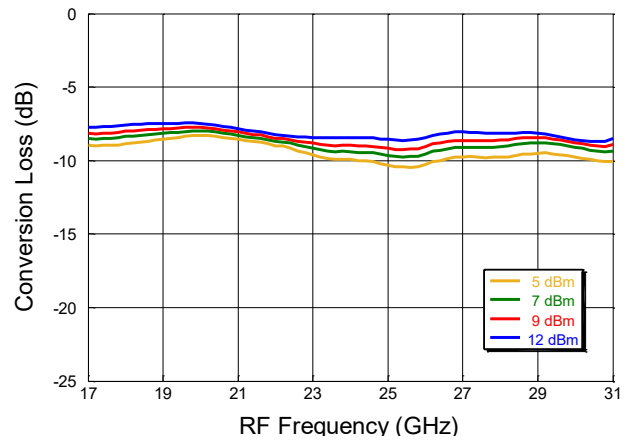

IIP3 over LO Drive vs. RF Frequency

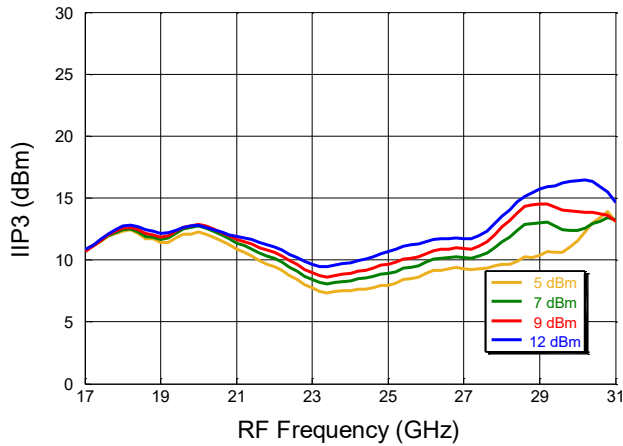

IIP2 over LO Drive vs. RF Frequency

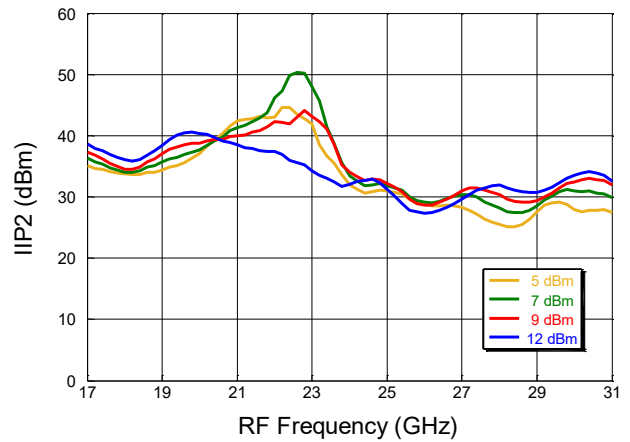

Double-Balanced Mixer

17 - 31 GHz



MAMX-011126

Rev. V1

Typical Performance Curves: Isolation and Return losses @ +25°C

LO to RF/IF Isolation vs. LO Frequency

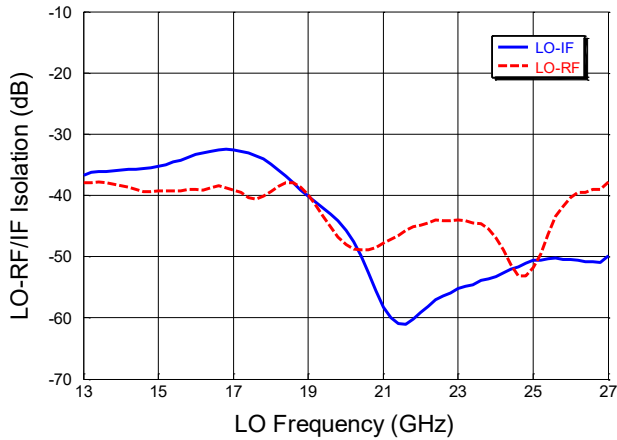

RF to IF Isolation vs. RF Frequency

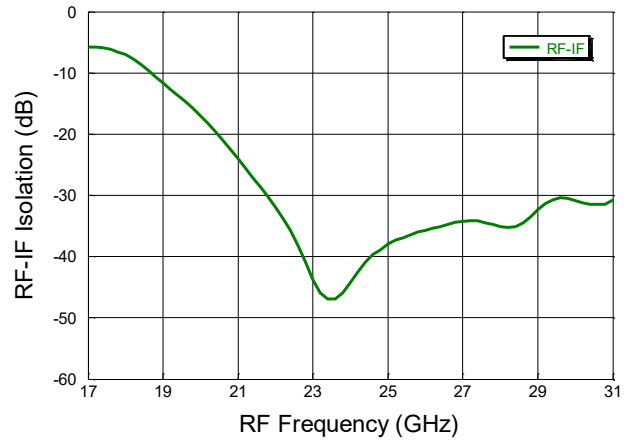

LO Return Loss vs. RF Frequency

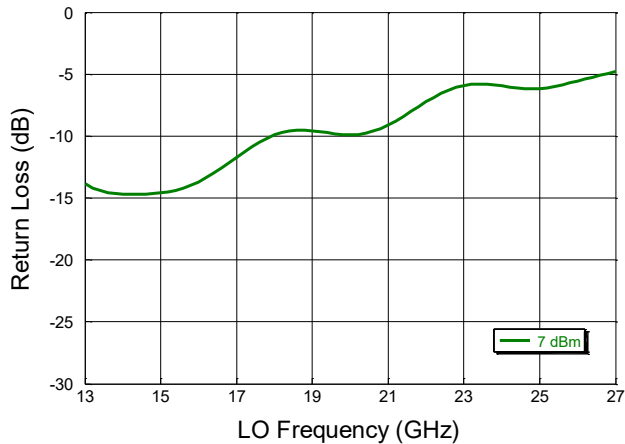

RF Return Loss vs. RF Frequency

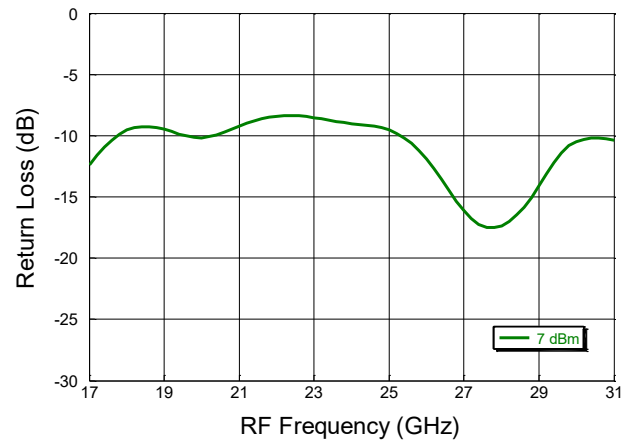

IF Return Loss vs. IF Frequency

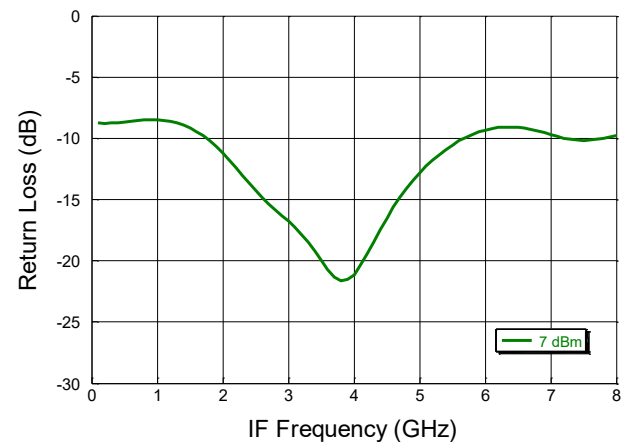

Double-Balanced Mixer

17 - 31 GHz



MAMX-011126

Rev. V1

Typical Performance Curves: Down Conversion Mode, Upper Side Band (USB), Low Side LO @ +25°C

P1dB vs. RF Frequency

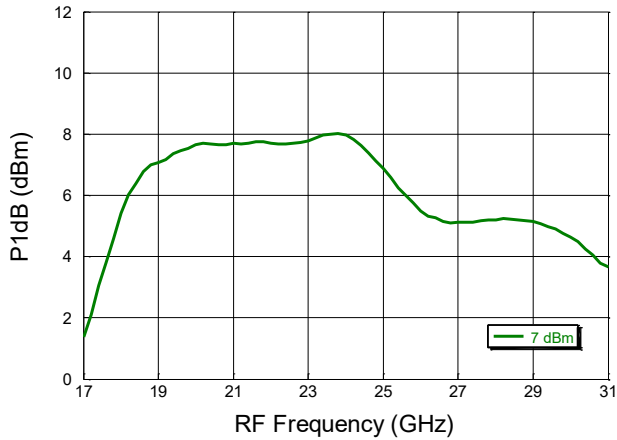

P1dB over LO drive

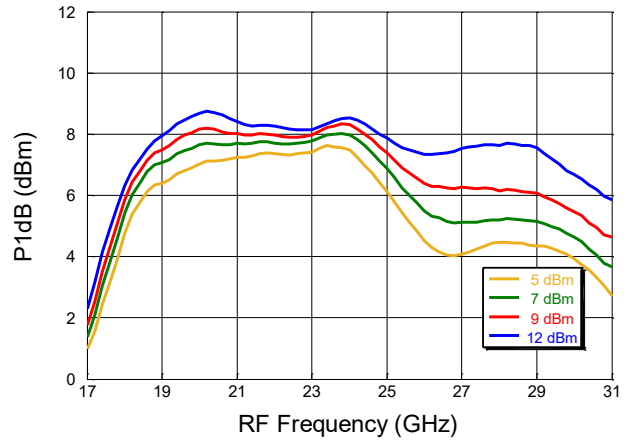

2RF x 2LO Spurious Suppression

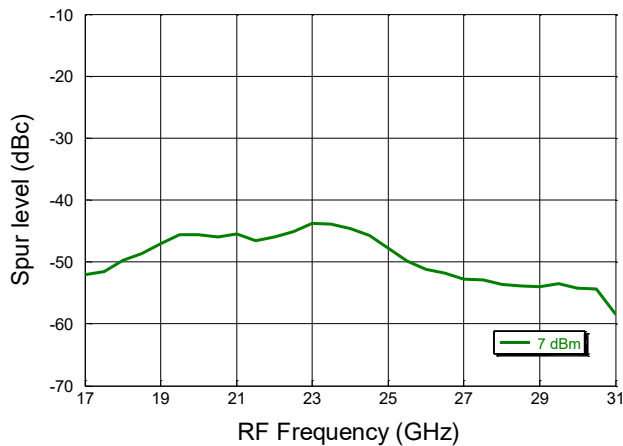

IF Bandwidth vs. IF Frequency

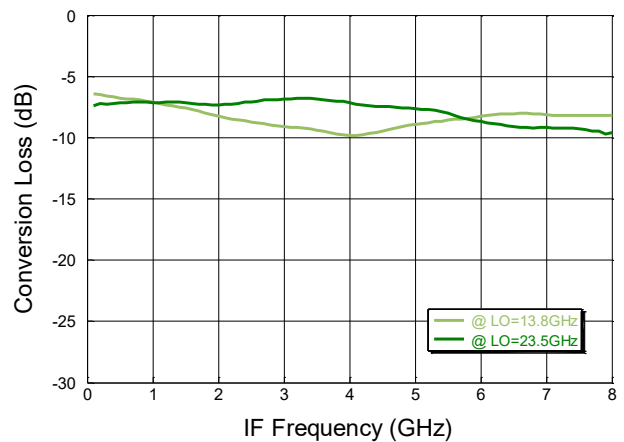

Double-Balanced Mixer

17 - 31 GHz



MAMX-011126

Rev. V1

Typical Performance Curves: Up Conversion Mode, Upper Side Band (USB),
Low Side LO @ +25°C. $I_F = 1$ GHz

Conversion Loss vs. Frequency

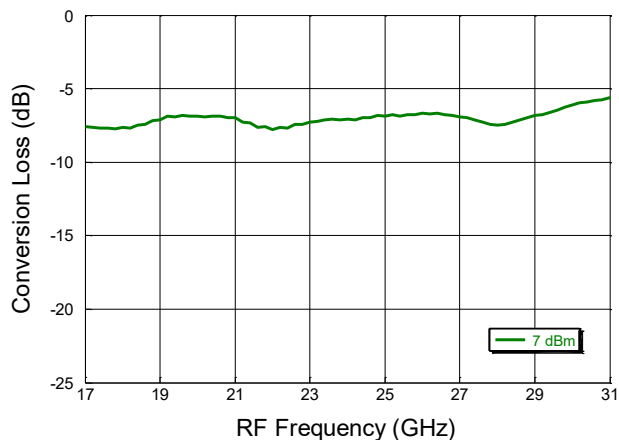

Conversion Loss over LO Drive

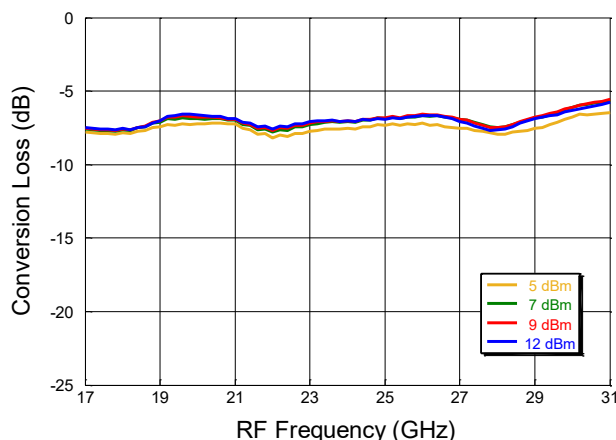

IIP3 over LO Drive vs. RF Frequency

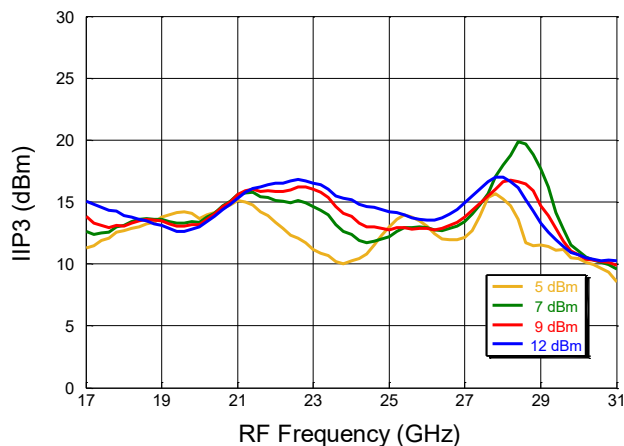

Double-Balanced Mixer 17 - 31 GHz



MAMX-011126

Rev. V1

Lead-Free 3 mm 12-Lead AQFN[†]

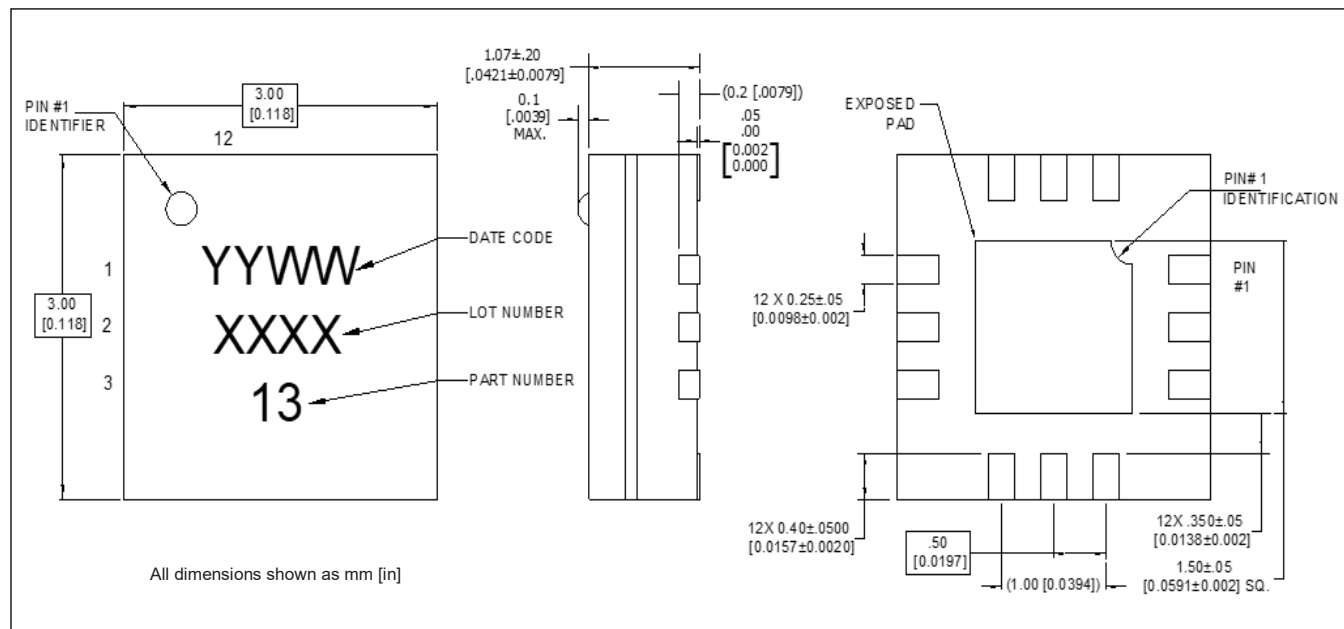

[†] Reference Application Note S2083 for lead-free solder reflow recommendations.
Meets JEDEC moisture sensitivity level 3 requirements.
Plating is NiPdAu.

MACOM Technology Solutions Inc. ("MACOM"). All rights reserved.

These materials are provided in connection with MACOM's products as a service to its customers and may be used for informational purposes only. Except as provided in its Terms and Conditions of Sale or any separate agreement, MACOM assumes no liability or responsibility whatsoever, including for (i) errors or omissions in these materials; (ii) failure to update these materials; or (iii) conflicts or incompatibilities arising from future changes to specifications and product descriptions, which MACOM may make at any time, without notice. These materials grant no license, express or implied, to any intellectual property rights.

THESE MATERIALS ARE PROVIDED "AS IS" WITH NO WARRANTY OR LIABILITY, EXPRESS OR IMPLIED, RELATING TO SALE AND/OR USE OF MACOM PRODUCTS INCLUDING FITNESS FOR A PARTICULAR PURPOSE, MERCHANTABILITY, INFRINGEMENT OF INTELLECTUAL PROPERTY RIGHT, ACCURACY OR COMPLETENESS, OR SPECIAL, INDIRECT, INCIDENTAL, OR CONSEQUENTIAL DAMAGES WHICH MAY RESULT FROM USE OF THESE MATERIALS.

MACOM products are not intended for use in medical, lifesaving or life sustaining applications. MACOM customers using or selling MACOM products for use in such applications do so at their own risk and agree to fully indemnify MACOM for any damages resulting from such improper use or sale.