

High Peak Power Surface Mount Limiter 2 - 20 GHz



MADL-011100

Rev. V2

Features

- Operating Frequency: 2 - 20 GHz
- Peak Power Operation: 58 dBm @ 13 GHz
- Insertion Loss: 1 dB @ 12 GHz
- Flat Leakage Power: 28 dBm @ 58 dBm
- Lead Free 8.8 x 5 x 1.8 mm package
- Passive Device, No DC Bias Required
- Internal DC Blocks and Return
- RoHS* Compliant

Applications

- Receiver Protection
- Ship and Airborne Radar

Description

The MADL-011100 is a lead-free wide band surface mount limiter that integrates multiple limiter stages and blocking capacitors into a compact laminate package. This device provides superior low and high signal performance from 2 to 20 GHz without DC bias.

The MADL-011100 is ideally suitable for high peak power receiver-protector microwave circuit applications where higher performance surface mount limiter assemblies are required.

Functional Schematic

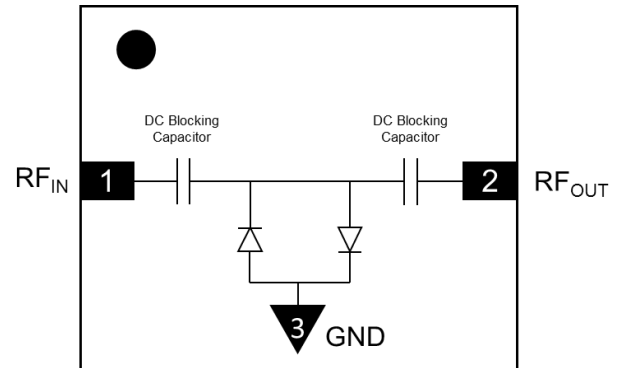

Pin Configuration

Pin #	Function
1	RF Input
2	RF Output
3 (Paddle) ¹	Ground

1. The exposed pad centered on the package bottom must be connected to RF, DC and thermal ground.

Ordering Information

Part Number	Package
MADL-011100	Parts in Waffle Pack
MADL-011100-SMB	Sample Board

* Restrictions on Hazardous Substances, compliant to current RoHS EU directive.

High Peak Power Surface Mount Limiter

2 - 20 GHz



MADL-011100

Rev. V2

Electrical Specifications: $T_A = +25^\circ\text{C}$, $Z_0 = 50 \Omega$, $P_{in} = -10 \text{ dBm}$ (unless otherwise specified)

Parameter	Test Conditions	Units	Min.	Typ.	Max.
Insertion Loss	2 GHz 12 GHz 18 GHz	dB	—	0.4 1.0 1.7	0.7 1.4 2.1
Return Loss	2 - 18 GHz	dB	—	15	—
P1dB	13 GHz	dBm	—	26	—
IIP3	-10 dBm per Tone, 10 MHz Spacing, F1 = 13.000 GHz F2 = 13.010 GHz	dBm	—	24	—
IIP2	-10 dBm per Tone, 10 MHz Spacing, F1 = 13.000 GHz F2 = 13.010 GHz	dBm	—	62	—
Peak Power Handling ²	1 μs PW, 1% Duty Cycle, 3 GHz 5 GHz 13 GHz 15 GHz	dBm	—	58 58 58 54	—
CW Power Handling ³	5 GHz	dBm	—	38	—
Flat Leakage Power	1 μs PW, 1% Duty Cycle, 13 GHz @ +58 dBm	dBm	—	28	—
Spike Leakage Power	1 μs PW, 1% Duty Cycle, 13 GHz @ +58 dBm	dBm	—	33	—
Spike Leakage Time	58 dBm Incident Power 1 μs RF Pulse Width, 1% Duty Cycle 13 GHz	ns	—	25	—
Spike Leakage Energy	55 dBm Incident Power 1 μs RF Pulse Width, 1% Duty Cycle 13 GHz	ergs	—	0.5	—
1 dB Recovery Time 3 dB Recovery Time	55 dBm Incident Power 1 μs RF Pulse Width, 1% Duty Cycle 5 GHz	ns	—	270 130	—

2. Both Source and Load VSWR < 1.2:1

High Peak Power Surface Mount Limiter

2 - 20 GHz



MADL-011100

Rev. V2

Recommended Operating Conditions³

Parameter	Recommended Operation Value
Peak Incident Power @ +85°C, 1 μs pulse, 1% duty 3 GHz 5 GHz 13 GHz	57 dBm 57 dBm 57 dBm
CW Incident Power @ +85°C	36 dBm
DC Voltage	40 V
Junction Temperature ²	175°C
Operating Temperature	-40°C to +85°C
Storage Temperature	-55°C to +150°C

3. Operating at nominal conditions with $T_J \leq +175^\circ\text{C}$ will ensure MTTF > 1×10^6 hours.

Absolute Maximum Ratings^{4,5}

Parameter	Absolute Maximum Value
Peak Incident Power @ +85°C, 1 μs pulse, 1% duty 3 GHz 5 GHz 13 GHz	58 dBm 58 dBm 58 dBm
CW Incident Power @ +85°C	37 dBm
DC Voltage ⁶	45 V
Junction Temperature ⁷	175°C
Operating Temperature	-40°C to +85°C
Storage Temperature	-55°C to +150°C

4. Exceeding any one or combination of these limits may cause permanent damage to this device.

5. MACOM does not recommend sustained operation near these survivability limits.

6. Maximum DC voltage applied externally to RF input and RF output DC blocking capacitors.

7. Operating at nominal conditions with $T_J \leq +175^\circ\text{C}$ will ensure MTTF > 1×10^6 hours.

Handling Procedures

Please observe the following precautions to avoid damage:

Static Sensitivity

These electronic devices are sensitive to electrostatic discharge (ESD) and can be damaged by static electricity. Proper ESD control techniques should be used when handling these devices.

High Peak Power Surface Mount Limiter 2 - 20 GHz



MADL-011100

Rev. V2

Typical Performance Curves: Freq. = 2 - 20 GHz, $Z_0 = 50 \Omega$

Insertion Loss

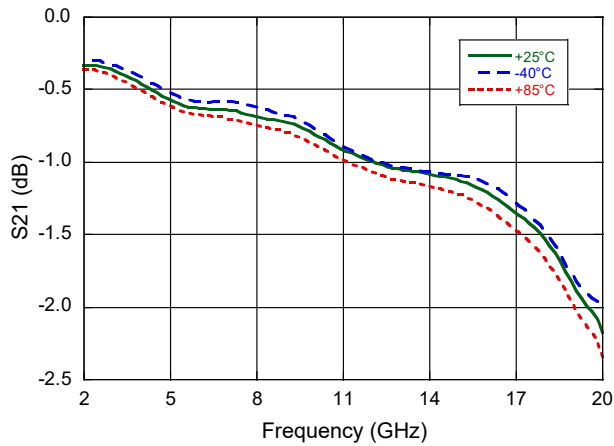

Input Return Loss

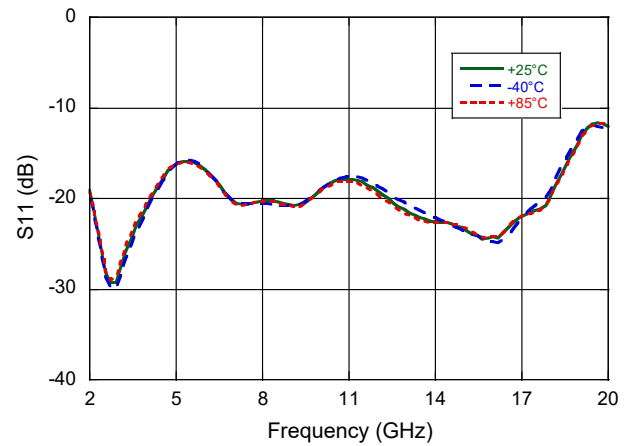

Output Return Loss

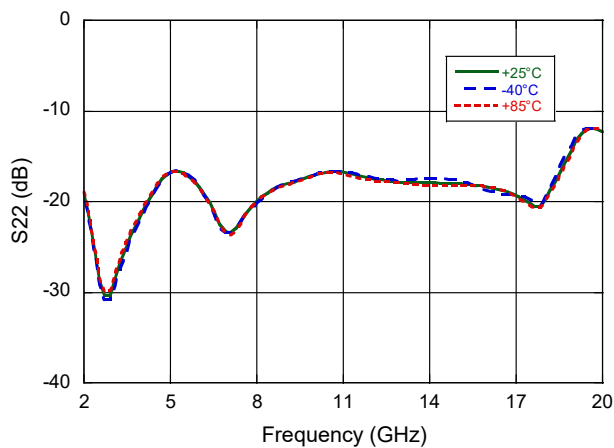

High Peak Power Surface Mount Limiter 2 - 20 GHz



MADL-011100

Rev. V2

Typical Performance Curves: 1 μ s Pulse Width, 1% Duty Cycle

Flat Leakage Power @ 5 GHz

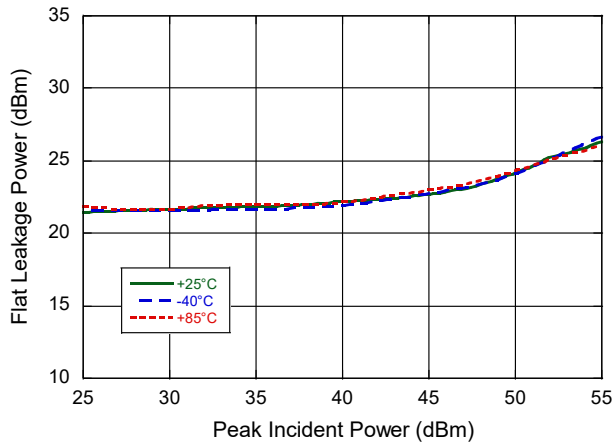

Spike Leakage Power @ 5 GHz

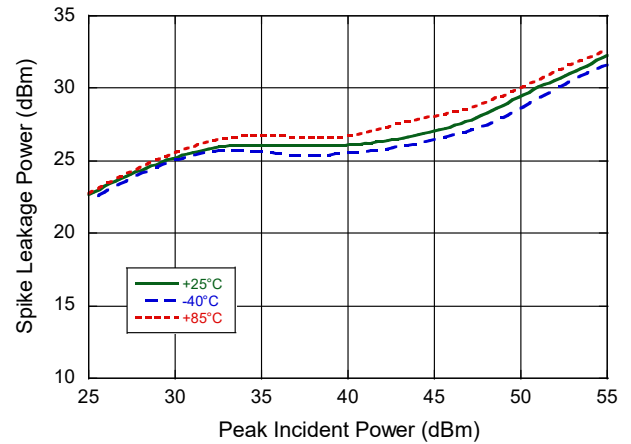

Recovery Time @ 5 GHz, 1 dB

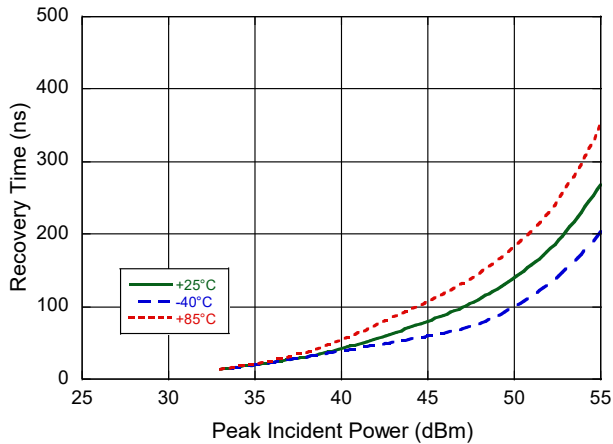

Recovery Time @ 5 GHz, 2 dB

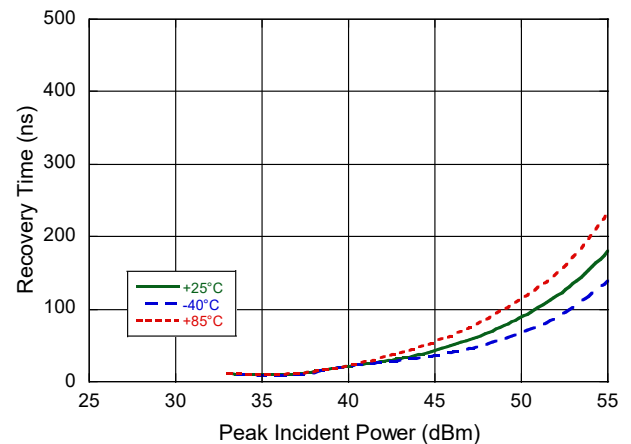

Recovery Time @ 5 GHz, 3 dB

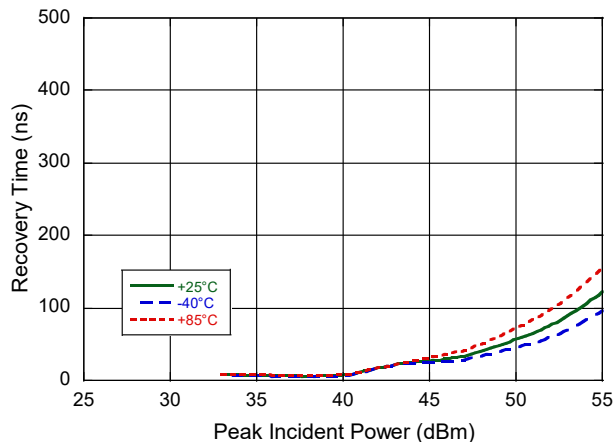

High Peak Power Surface Mount Limiter 2 - 20 GHz



MADL-011100

Rev. V2

Typical Performance Curves: $Z_0 = 50 \Omega$

**Flat Leakage Power @ 1 GHz,
1 μ s RF Pulse Width, 1% Duty Cycle**

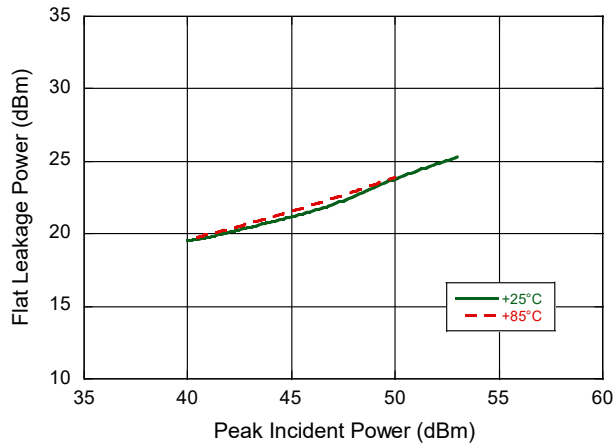

**Spike Leakage Power @ 1 GHz,
1 μ s RF Pulse Width, 1% Duty Cycle**

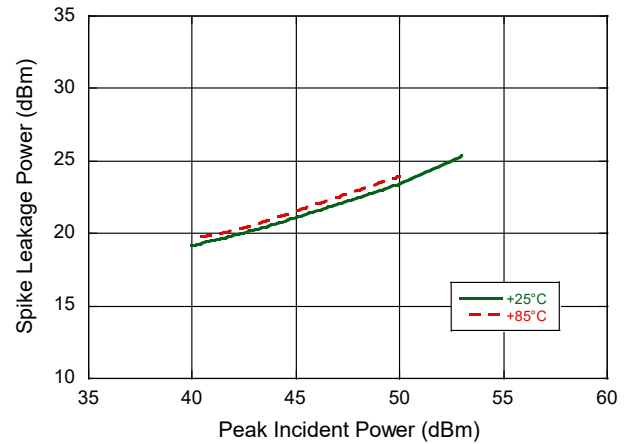

**Flat & Spike Leakage Power @ 1 GHz,
10 μ s RF Pulse Width, 2% Duty Cycle**

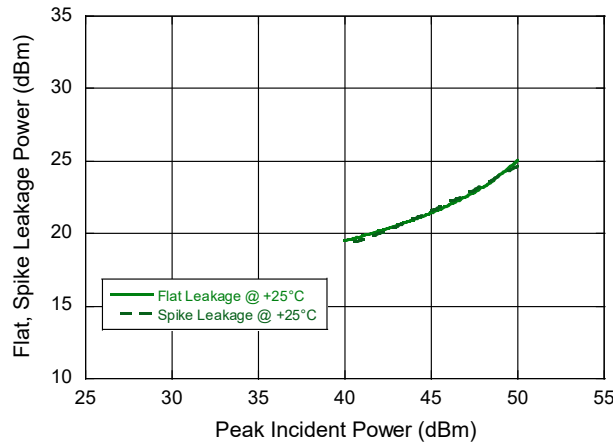

High Peak Power Surface Mount Limiter 2 - 20 GHz



MADL-011100

Rev. V2

Typical Performance Curves: $Z_0 = 50 \Omega$

**Flat Leakage Power @ 3 GHz,
1 μ s RF Pulse Width, 1% Duty Cycle**

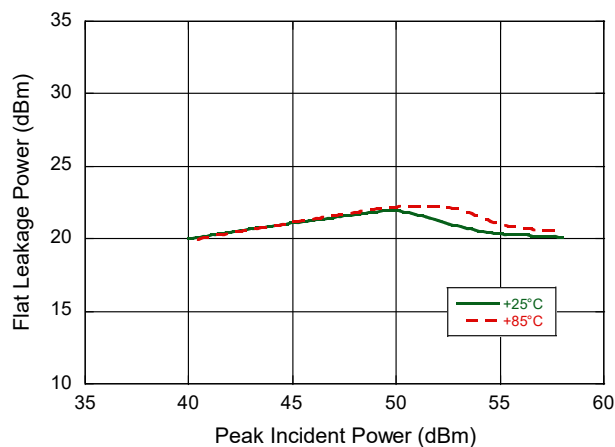

**Spike Leakage Power @ 3 GHz,
1 μ s RF Pulse Width, 1% Duty Cycle**

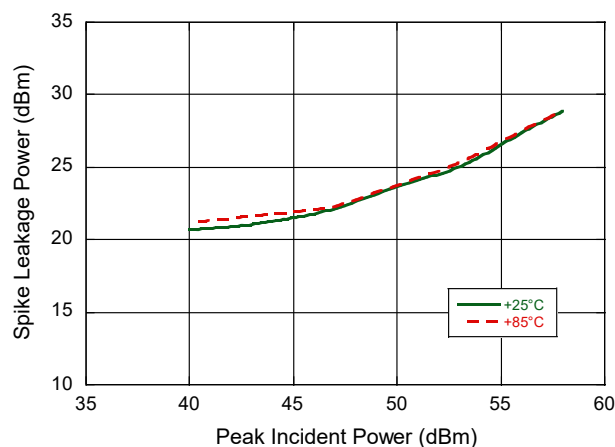

**Flat Leakage Power @ 3 GHz,
10 μ s RF Pulse Width, 2% Duty Cycle**

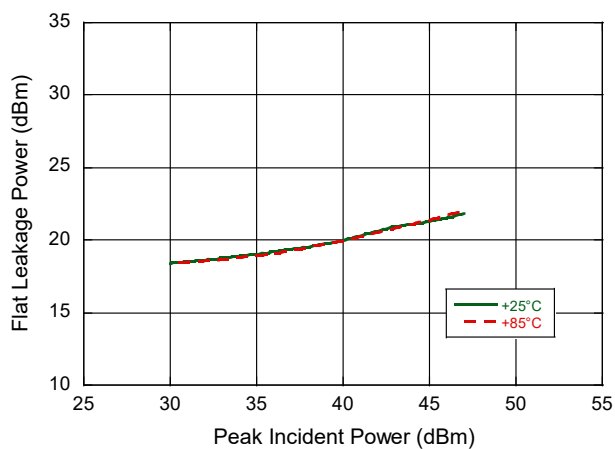

**Spike Leakage Power @ 3 GHz,
10 μ s RF Pulse Width, 2% Duty Cycle**

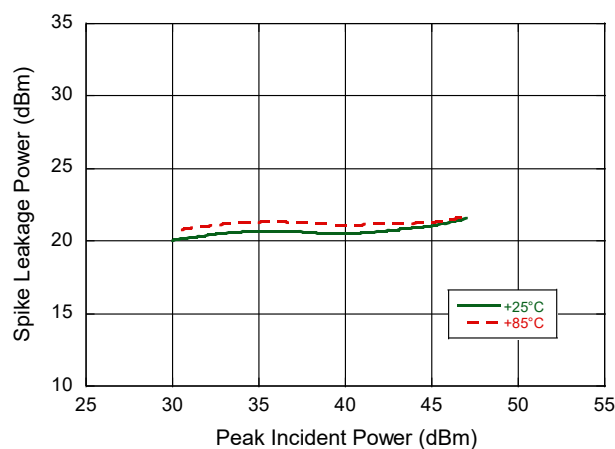

High Peak Power Surface Mount Limiter 2 - 20 GHz



MADL-011100

Rev. V2

Typical Performance Curves: 1 μ s RF Pulse Width, 1% Duty Cycle

Flat Leakage Power @ 13 GHz

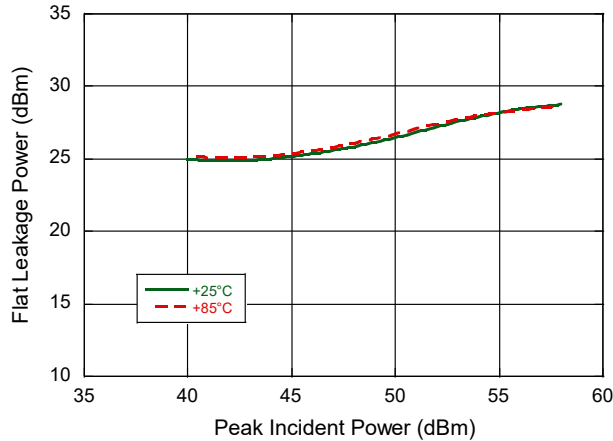

Spike Leakage Power @ 13 GHz

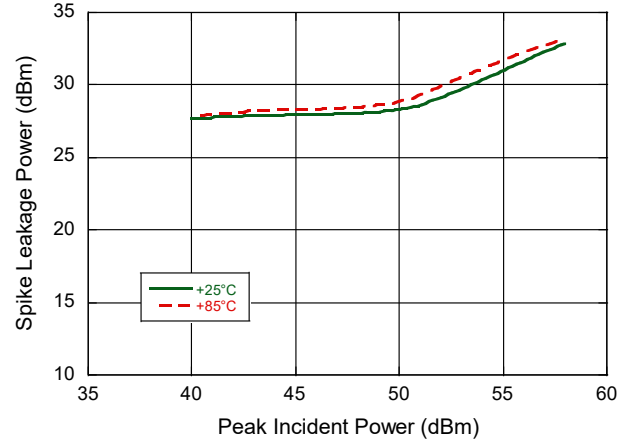

Flat Leakage Power @ 15 GHz

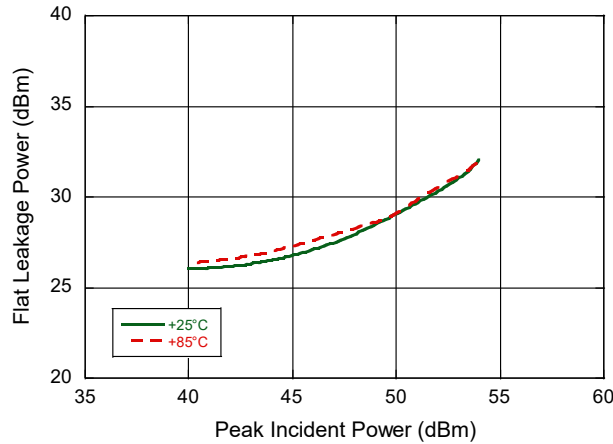

Spike Leakage Power @ 15 GHz

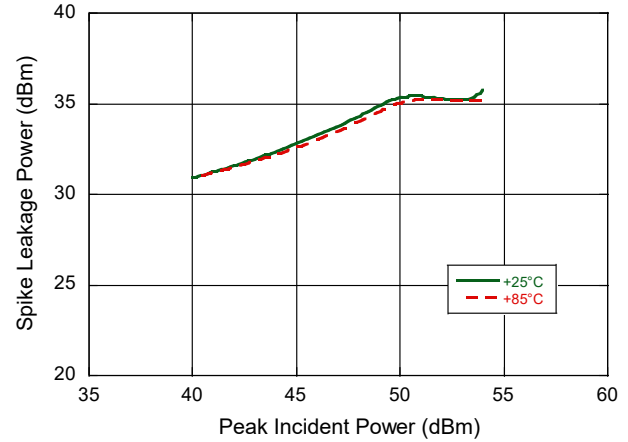

Flat Leakage Power @ 18 GHz

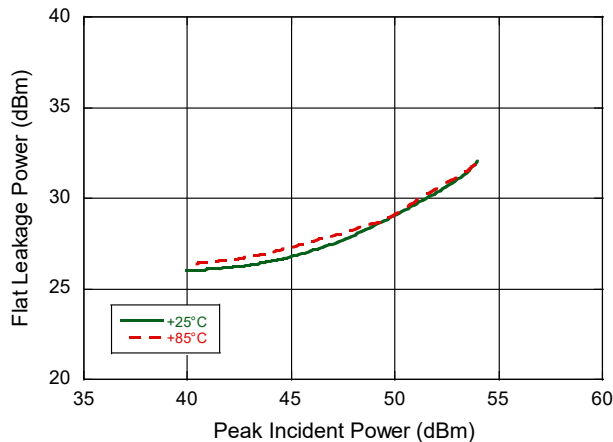

Spike Leakage Power @ 18 GHz

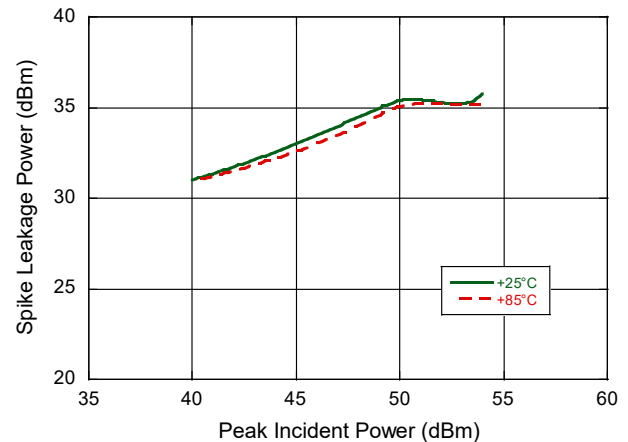

High Peak Power Surface Mount Limiter 2 - 20 GHz



MADL-011100

Rev. V2

Recommended Solder Mask Pattern on SMB to Prevent Voiding (units in mm)

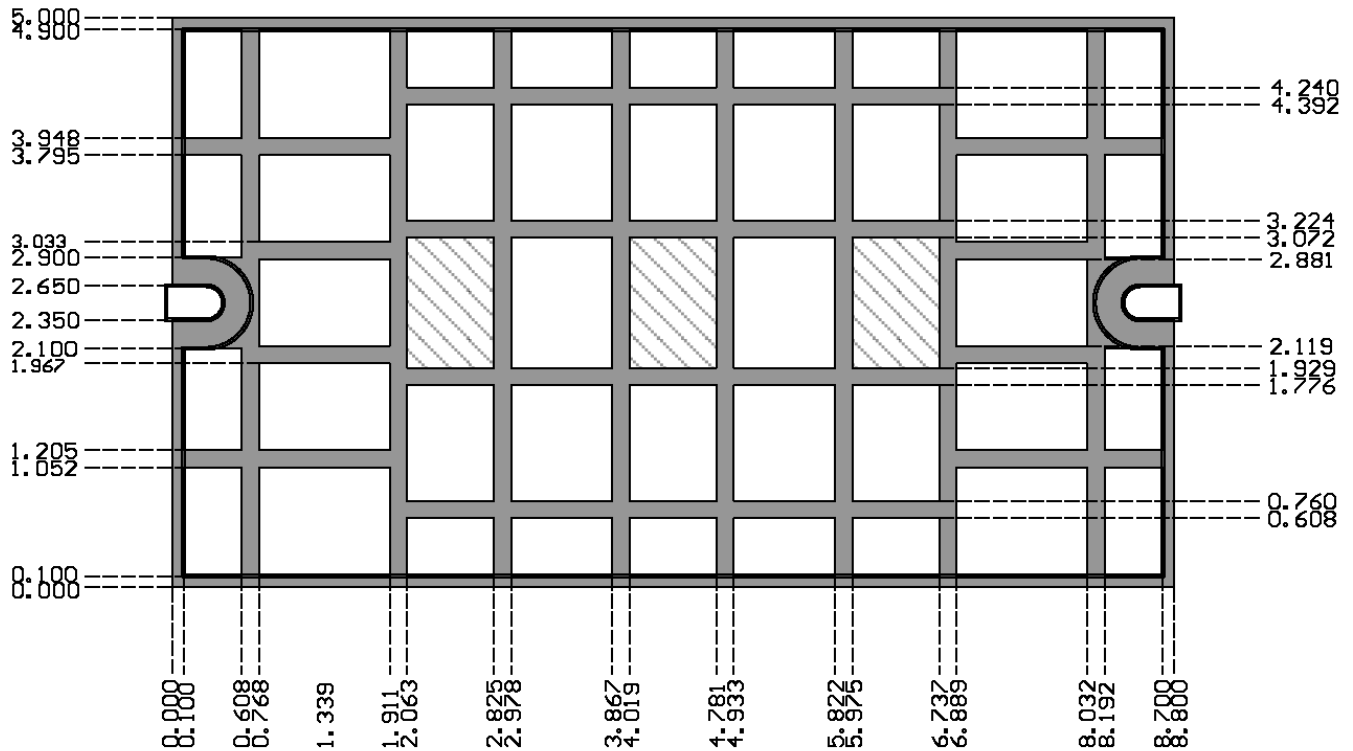

Diode Locations: Minimize solder voiding

Recommended Attachment

A High density solid Cu via farm or Solid Cu heat Slug is recommended under the attach pad for optimum thermal heat dissipation. Solder voiding under the package should be minimized and no voiding should be present under the diode locations.

High Peak Power Surface Mount Limiter 2 - 20 GHz



MADL-011100

Rev. V2

Outline Drawing: Lead-Free 8.8 mm x 5 mm x 1.8 mm 2-Lead Package[†]

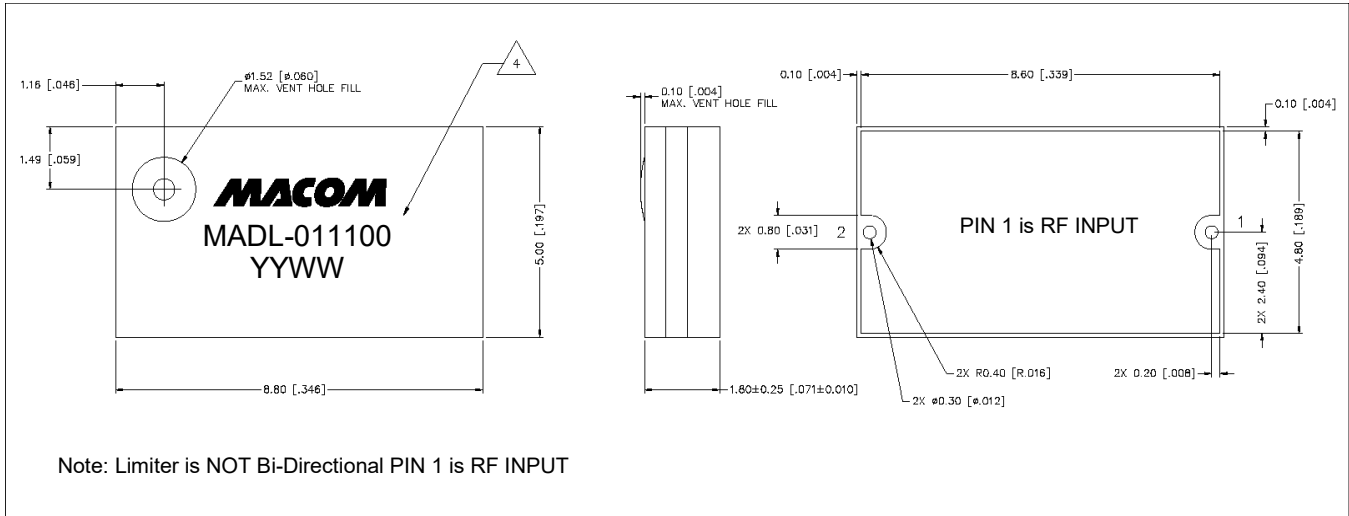

[†] Reference Application Note S2083 for lead-free solder reflow recommendations.
Meets JEDEC moisture sensitivity level (MSL) 3 requirements.
Plating is Au over Pd over Ni over Cu

High Peak Power Surface Mount Limiter

2 - 20 GHz



MADL-011100

Rev. V2

MACOM Technology Solutions Inc. ("MACOM"). All rights reserved.

These materials are provided in connection with MACOM's products as a service to its customers and may be used for informational purposes only. Except as provided in its Terms and Conditions of Sale or any separate agreement, MACOM assumes no liability or responsibility whatsoever, including for (i) errors or omissions in these materials; (ii) failure to update these materials; or (iii) conflicts or incompatibilities arising from future changes to specifications and product descriptions, which MACOM may make at any time, without notice. These materials grant no license, express or implied, to any intellectual property rights.

THESE MATERIALS ARE PROVIDED "AS IS" WITH NO WARRANTY OR LIABILITY, EXPRESS OR IMPLIED, RELATING TO SALE AND/OR USE OF MACOM PRODUCTS INCLUDING FITNESS FOR A PARTICULAR PURPOSE, MERCHANTABILITY, INFRINGEMENT OF INTELLECTUAL PROPERTY RIGHT, ACCURACY OR COMPLETENESS, OR SPECIAL, INDIRECT, INCIDENTAL, OR CONSEQUENTIAL DAMAGES WHICH MAY RESULT FROM USE OF THESE MATERIALS.

MACOM products are not intended for use in medical, lifesaving or life sustaining applications. MACOM customers using or selling MACOM products for use in such applications do so at their own risk and agree to fully indemnify MACOM for any damages resulting from such improper use or sale.