

High Gain High Linearity 0.5 W Driver Amplifier 1.7 - 2.9 GHz



MAAM-011302

Rev. V1

Features

- 2-Stage Driver Amplifier with simple bias control circuit
- 1.7 - 2.9 GHz wideband operation frequency
- No External Matching Components Required
- Gain: 38 dB
- Low quiescent Current: 150 mA
- OP1dB: 26 dBm
- OP3dB: 27 dBm
- Output IP3: 41 dBm
- Noise Figure: 4.0 dB
- Single supply voltage: 5 V
- Logic voltage: 1.8 or 3.3 V
- Lead-Free 3 mm 16 Lead SMT Package
- RoHS* Compliant

Applications

- 5G Massive MIMO
- Small Cell BTS
- Wireless Infrastructure
- Multi Market

Description

The MAAM-011302 is a wideband high linearity driver amplifier packaged in a compact 3 mm 16-Lead SMT package. This driver amplifier provides 38 dB gain, 26 dBm OP1dB, and 41 dBm OIP3 with 150 mA quiescent current and device ON/OFF function to support TDD system applications. RF input and output ports are internally matched over the entire operating frequency range of 1.7 - 2.9 GHz.

Ordering Information¹

Part Number	Package
MAAM-011302-TR1000	1000 piece reel
MAAM-011302-001SMB	Sample Board

1. Reference Application Note M513 for reel size information.

Functional Schematic

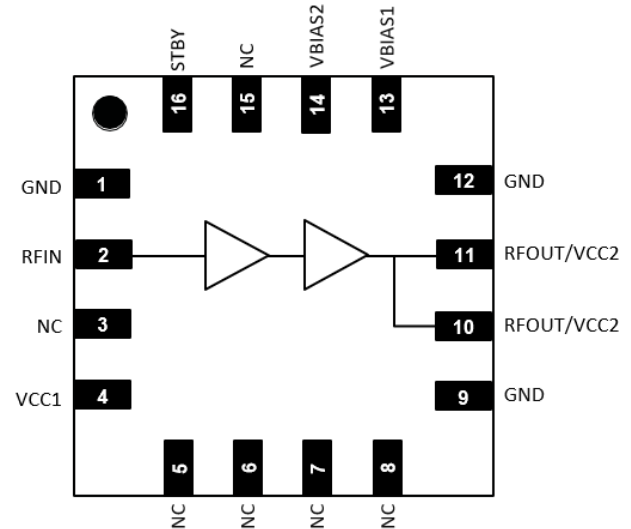

Pin Names

Pin #	Function
1, 9, 12	GND
2	RFIN
3, 5 - 8, 15	No connection ²
4	VCC1
10 - 11	RFOUT/VCC2
13	VBIAS1
14	VBIAS2
16	STBY
17	Paddle ³

2. MACOM recommends connecting No Connection (N/C) pins to ground.

3. The exposed pad centered on the package bottom must be connected to RF, DC and thermal ground.

* Restrictions on Hazardous Substances, compliant to current RoHS EU directive.

High Gain High Linearity 0.5 W Driver Amplifier 1.7 - 2.9 GHz



MAAM-011302

Rev. V1

Pin Description

Pin #	Name	Description
1, 9, 12	GND	These pins are grounded internally.
2	RFIN	RF input. Internally DC blocked.
3, 6 - 8, 15	NC	No connection. Can be connected to ground. Not connected internally.
4	VCC1	DC supply voltage. Place bypass capacitor as close to pin as possible.
5	NC	No connection. Can be connected to ground. Grounded internally.
10, 11	RFOUT/ VCC2	RF output. DC bias current is injected through these two pins. Supply voltage through a choke coil. DC-blocking capacitor is required following the choke coil. Place bypass capacitor as close to the choke coil as possible.
13	VBIAS1	DC supply voltage for Bias Circuit. Place bypass capacitor as close to pin as possible. VBIAS1 should be connected to VCC1 and VCC2 single supply.
14	VBIAS2	No connection. Leave open (floating).
16	STBY	Supply amplifier ON/OFF logic control voltage.
17	Paddle	Must be connected to RF, DC, and thermal ground. This pin is grounded internally.

High Gain High Linearity 0.5 W Driver Amplifier

1.7 - 2.9 GHz



MAAM-011302

Rev. V1

AC Electrical Specifications:

Freq. = 2.5 GHz, $T_c^4 = +25^\circ\text{C}$, $V_{CC1} = V_{CC2} = V_{BIAS1} = +5\text{ V}$, $Z_0 = 50\ \Omega$

Parameter	Test Conditions	Units	Min.	Typ.	Max.
Gain	1.8 GHz 2.5 GHz	dB	38.0 36.0	40.5 38.5	—
Gain Flatness	Any 100MHz	dB	—	0.3	—
Output P1dB	—	dBm	—	25	—
Output P3dB	—	dBm	—	27	—
Output IP3	$P_{OUT} = +12\text{ dBm / tone, } \Delta f = 10\text{ MHz}$	dBm	—	41	—
Input Return Loss	—	dB	—	15	—
Output Return Loss	—	dB	—	15	—
Noise Figure	—	dB	—	4.0	—
Power Consumption	V_{CC1} , V_{BIAS1} , R_{FOUT}/V_{CC2} Active state	W	—	0.75	—
Power Consumption	V_{CC1} , I_{BIAS} , R_{FOUT}/V_{CC2} Standby state	W	—	0.005	—

4. T_c is defined by exposed paddle temperature.

DC Electrical Specifications: $T_c^4 = +25^\circ\text{C}$, $V_{CC1} = V_{CC2} = V_{BIAS1} = +5\text{ V}$, $Z_0 = 50\ \Omega$

Parameter	Test Conditions	Units	Min.	Typ.	Max.
Standby to Active Mode Settling Time	RFIN to RFOUT gain settled within 0.1 dB of final value after STBY command	ns	—	300	—
Active to Standby Mode Settling Time	RFIN to RFOUT signal reduced at least 30 dB after STBY command	ns	—	300	—
Supply Voltage ⁵	V_{CC1} , R_{FOUT}/V_{CC2} , V_{BIAS1}	V	4.75	5	5.25
Supply Current ⁵	V_{CC1} , R_{FOUT}/V_{CC2} , V_{BIAS1}	mA	—	150	—
Logic Control Voltage	Logic High, STBY Logic Low, STBY	V	1.17 0	—	3.3 0.63
Logic input Current	Logic High/Low, STBY	μA	-10	—	10

5. Connect V_{BIAS1} , V_{CC1} , and V_{CC2} to a single supply.

Truth Table

PIN	Device Control	
STBY	Logic High	Device Active Mode
	Logic Low	Device Standby Mode

High Gain High Linearity 0.5 W Driver Amplifier 1.7 - 2.9 GHz



MAAM-011302

Rev. V1

Recommended Operating Conditions

Parameter	Symbol	Unit	Min.	Typ.	Max.
DC Power Supply ⁵	VCC1, VCC2, VBIAS1	V	4.75	5.0	5.25
Operating Temperature ⁴	T _c	°C	-40	—	105
Junction Temperature ^{6,7}	T _J	°C	—	—	150

6. Operating at nominal conditions with T_J ≤ +150 °C will ensure MTTF > 1 x 10⁶ hours.

7. Junction Temperature (T_J) = T_C + θ_{JC} * PDISS where PDISS is the total DC & RF dissipated power. Typical thermal resistance (θ_{JC}) = 47 °C/W.

a) For T_C = +25°C, T_J = 59 °C @ 5 V

b) For T_C = +105°C, T_J = 146 °C @ 5 V

Absolute Maximum Ratings^{8,9}

Parameter	Symbol	Unit	Min.	Max.
Input Power	RFIN	dBm	—	20
DC Supply Voltage ⁵	VCC1, VCC2, VBIAS1	V	-0.5	5.5
Logic Control Voltage	STBY	V	-0.5	3.6
Operating Temperature ⁴	T _c	°C	-40	125
Storage Temperature ⁴	T _c	°C	-65	150

8. Exceeding any one or combination of these limits may cause permanent damage to this device.

9. MACOM does not recommend sustained operation near these survivability limits.

Handling Procedures

Please observe the following precautions to avoid damage:

Static Sensitivity

These electronic devices are sensitive to electrostatic discharge (ESD) and can be damaged by static electricity. Proper ESD control techniques should be used when handling these HBM Class 1B and CDM Class C3 devices.

High Gain High Linearity 0.5 W Driver Amplifier 1.7 - 2.9 GHz



MAAM-011302

Rev. V1

PCB Layout

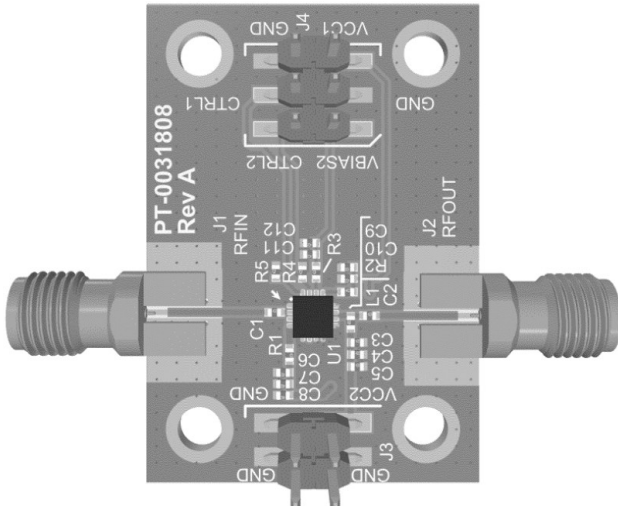

Parts List

Part	Value	Case Style
C1	24 pF	0402
C2	5 pF	0402
C3, C6, C9	100 pF	0402
C4, C7, C10	1 μ F	0402
L1	18 nH	0402
R1, R2	0 Ω	0402
R5	1k Ω	0402

Application Schematic¹⁰

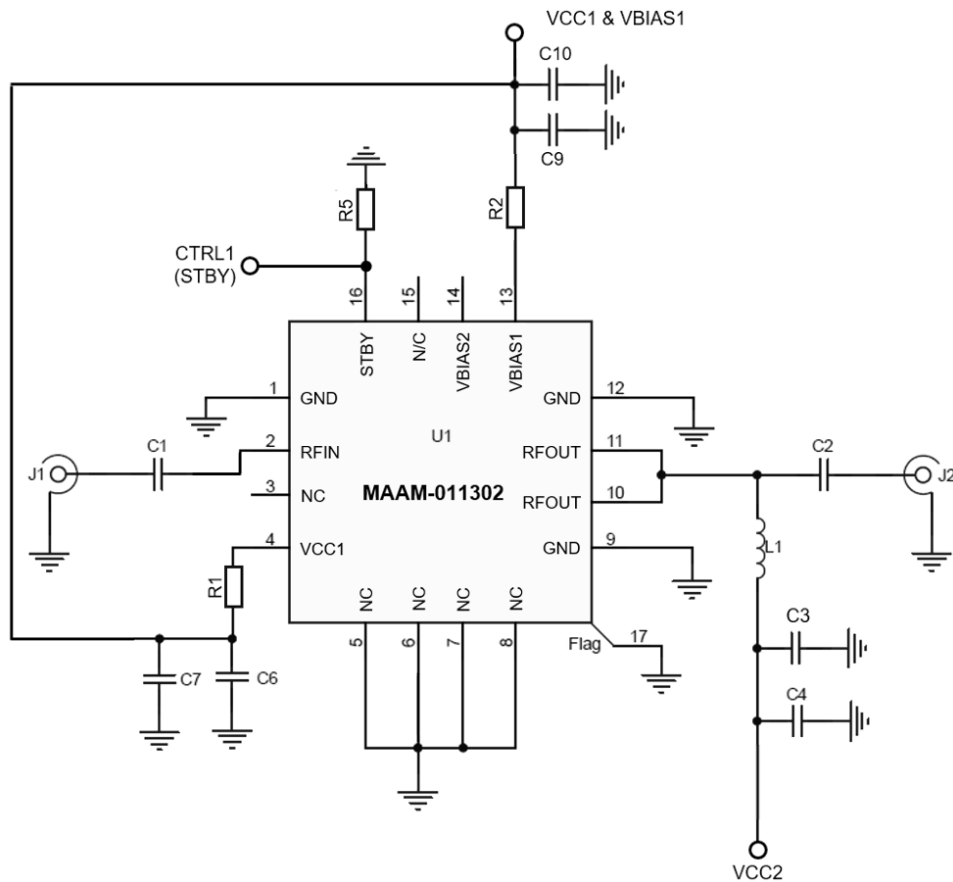

10. Connect VBIAS1, VCC1, and VCC2 pins to a single +5 V supply. Connect CTRL1 pin to 0 V / 1.8 V Logic pin for STBY control. Leave VBIAS2 and CTRL2 pins open (floating).

5

MACOM Technology Solutions Inc. (MACOM) and its affiliates reserve the right to make changes to the product(s) or information contained herein without notice. Visit www.macom.com for additional data sheets and product information.

For further information and support please visit:
<https://www.macom.com/support>

DC-0031059

High Gain High Linearity 0.5 W Driver Amplifier 1.7 - 2.9 GHz



MAAM-011302
Rev. V1

Typical Performance Curves

$P_{IN} = -35$ dBm, $VCC1 = VCC2 = VBIAS1 = +5$ V, $Z_0 = 50 \Omega$ (unless otherwise stated)

Gain¹¹, 1.7 - 2.9 GHz

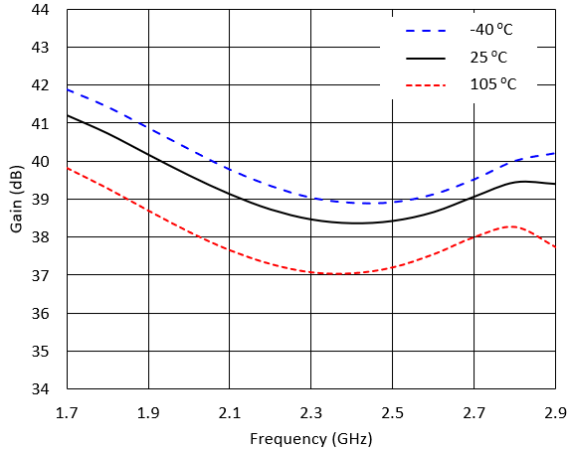

Noise Figure¹¹, 1.7 - 2.9 GHz

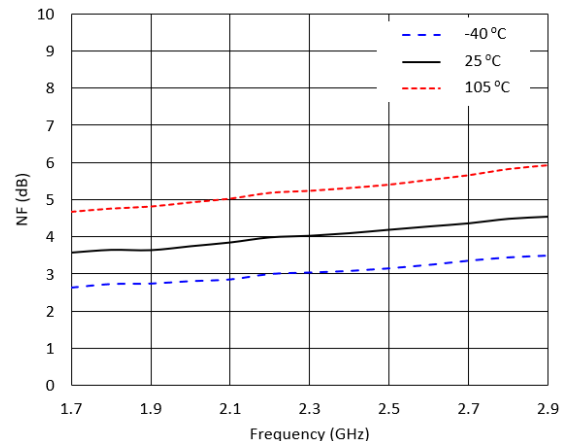

Input Return Loss, 1.7 - 2.9 GHz

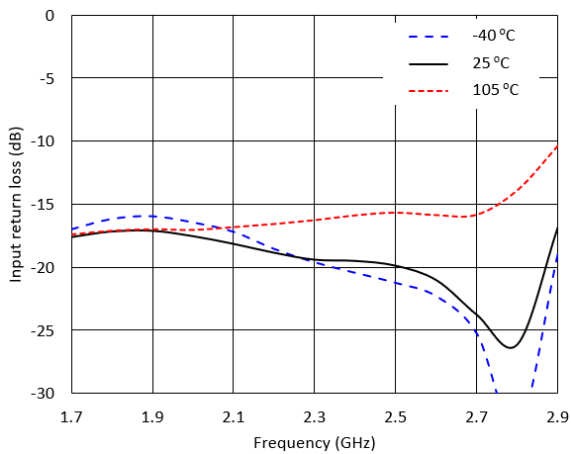

Output Return Loss, 1.7 - 2.9 GHz

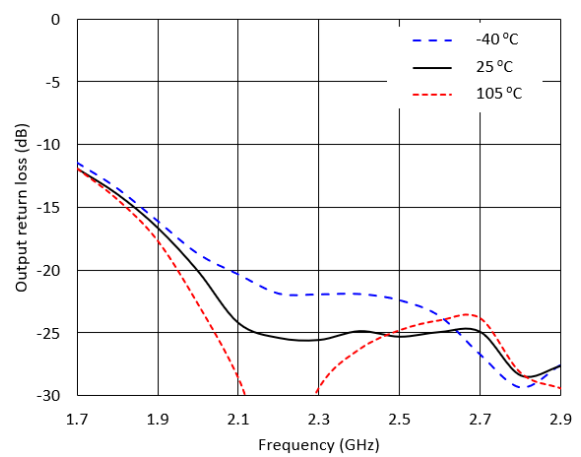

Output P_{1dB}^{11} , 1.7 - 2.9 GHz

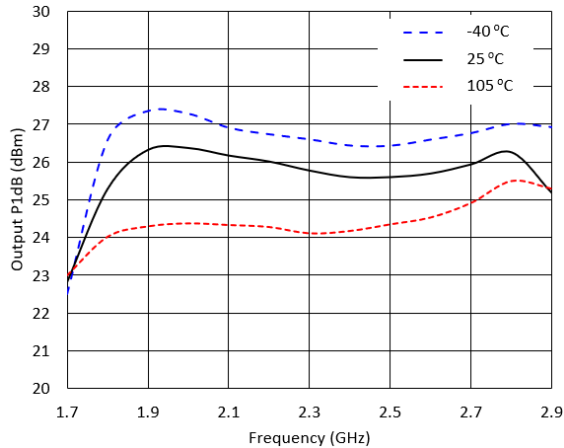

Gain vs. Output power¹¹, 1.8 GHz

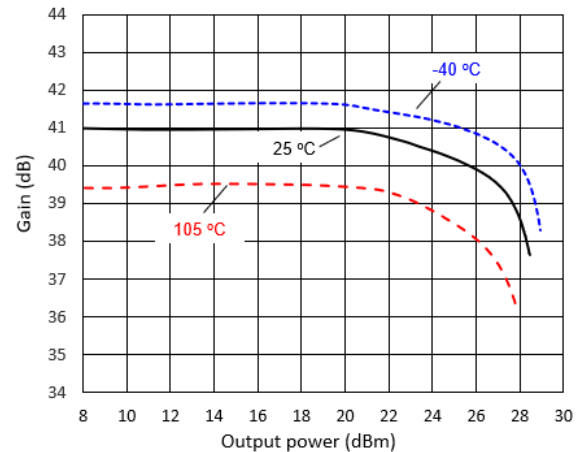

6 11. For Gain, Noise Figure, and Output P_{1dB} plots, RF trace and connector losses are de-embedded.

MACOM Technology Solutions Inc. (MACOM) and its affiliates reserve the right to make changes to the product(s) or information contained herein without notice. Visit www.macom.com for additional data sheets and product information.

High Gain High Linearity 0.5 W Driver Amplifier 1.7 - 2.9 GHz



MAAM-011302
Rev. V1

Typical Performance Curves

VCC1 = VCC2 = VBIAS1 = +5 V, Z₀ = 50 Ω (unless otherwise stated)

ICC vs. Output power¹¹, 1.8 GHz

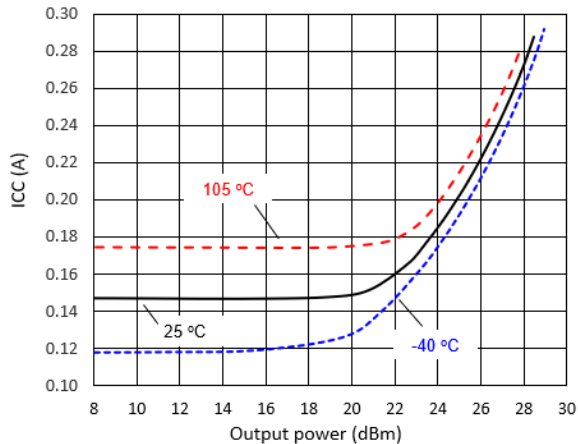

Gain vs. Output power¹¹, 2.5 GHz

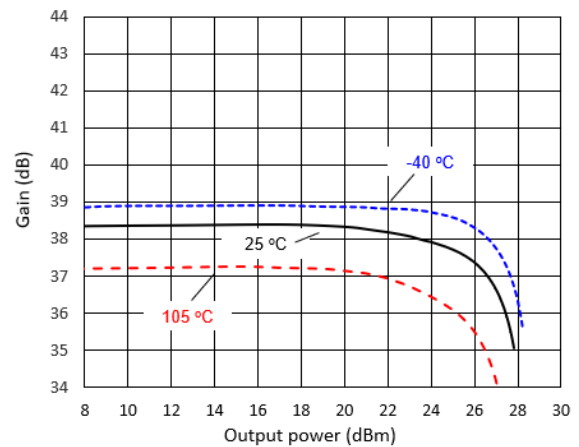

ICC vs. Output power¹¹, 2.5 GHz

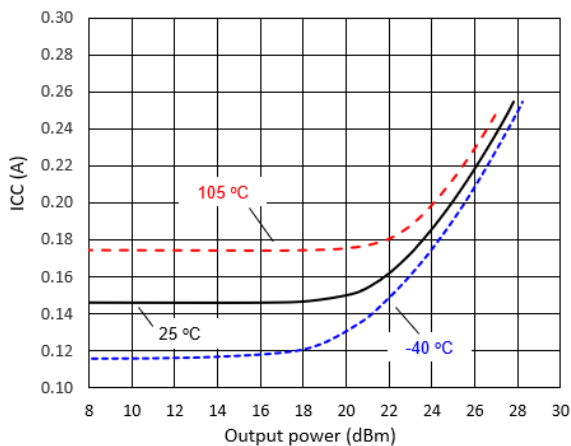

Output IP3 vs. Output power / tone, +25 °C

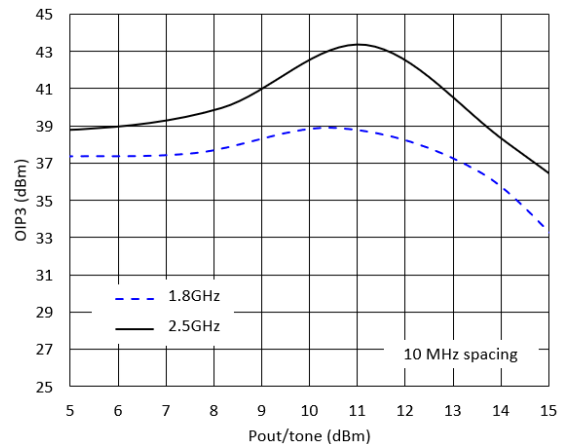

IMD3 vs. Output power / tone, 1.8 GHz

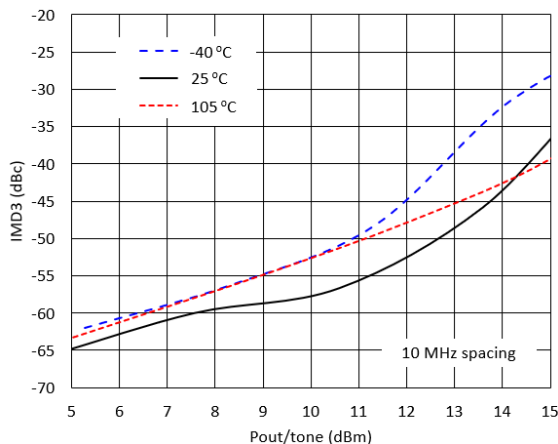

IMD3 vs. Output power / tone, 2.5 GHz

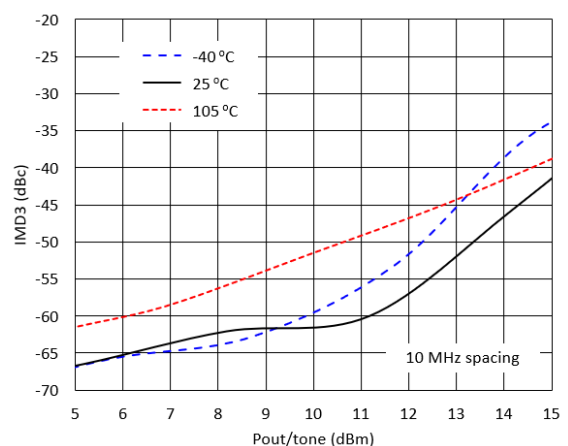

High Gain High Linearity 0.5 W Driver Amplifier 1.7 - 2.9 GHz



MAAM-011302

Rev. V1

Lead-Free 3 mm 16-Lead SMT[†]

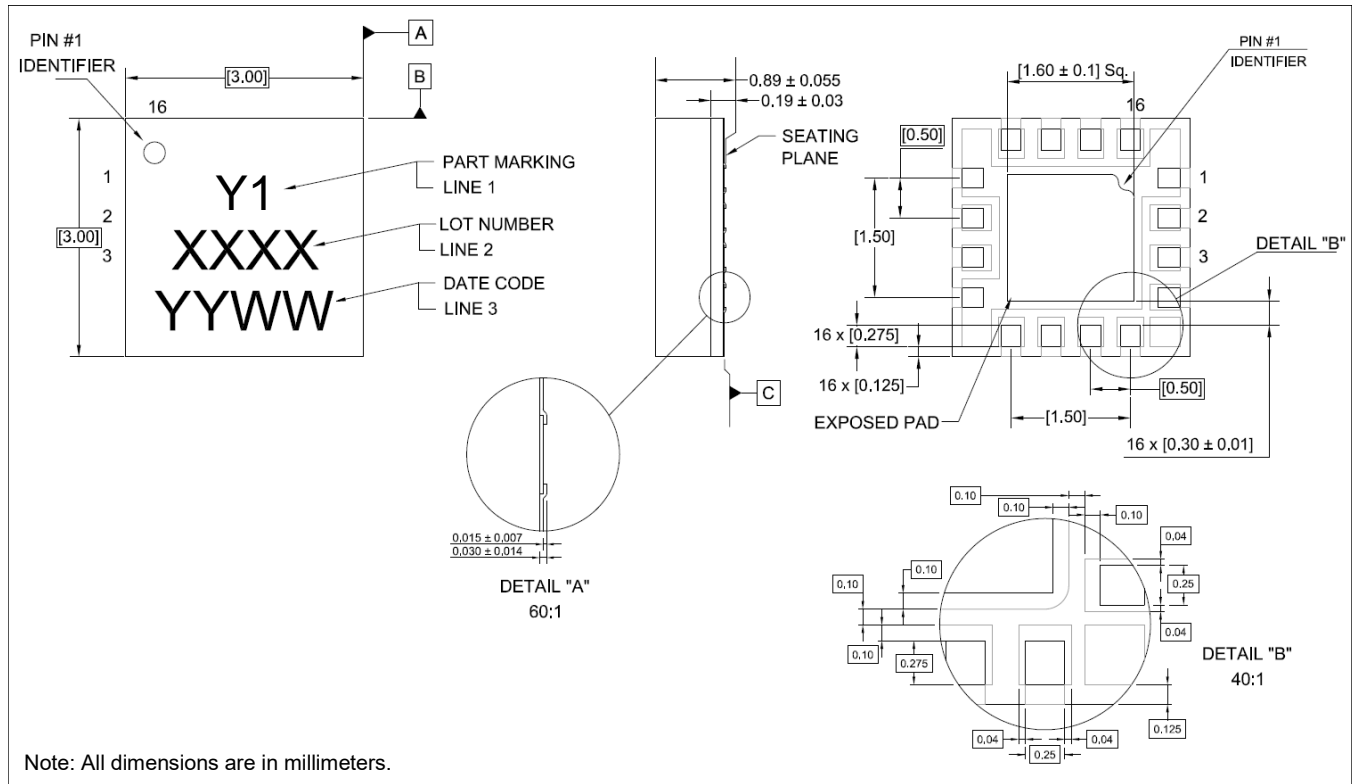

[†] Reference Application Note S2083 for lead-free solder reflow recommendations.
Meets JEDEC moisture sensitivity level 3 requirements in accordance to JEDEC J-STD-020D.
Plating is NiPdAu over copper

Revision History

Rev	Date	Change Description
V1	12/21/23	Initial release.

High Gain High Linearity 0.5 W Driver Amplifier 1.7 - 2.9 GHz



MAAM-011302

Rev. V1

MACOM Technology Solutions Inc. ("MACOM"). All rights reserved.

These materials are provided in connection with MACOM's products as a service to its customers and may be used for informational purposes only. Except as provided in its Terms and Conditions of Sale or any separate agreement, MACOM assumes no liability or responsibility whatsoever, including for (i) errors or omissions in these materials; (ii) failure to update these materials; or (iii) conflicts or incompatibilities arising from future changes to specifications and product descriptions, which MACOM may make at any time, without notice. These materials grant no license, express or implied, to any intellectual property rights.

THESE MATERIALS ARE PROVIDED "AS IS" WITH NO WARRANTY OR LIABILITY, EXPRESS OR IMPLIED, RELATING TO SALE AND/OR USE OF MACOM PRODUCTS INCLUDING FITNESS FOR A PARTICULAR PURPOSE, MERCHANTABILITY, INFRINGEMENT OF INTELLECTUAL PROPERTY RIGHT, ACCURACY OR COMPLETENESS, OR SPECIAL, INDIRECT, INCIDENTAL, OR CONSEQUENTIAL DAMAGES WHICH MAY RESULT FROM USE OF THESE MATERIALS.

MACOM products are not intended for use in medical, lifesaving or life sustaining applications. MACOM customers using or selling MACOM products for use in such applications do so at their own risk and agree to fully indemnify MACOM for any damages resulting from such improper use or sale.