

GaN Low Noise Amplifier

24 - 34 GHz



MAAL-011251-DIE

Rev. V2

Features

- Noise Figure: 1.6 dB
- Gain: 18 dB
- Including DC Current Regulation
- DC Consumption: 50 mA
- Drain Voltage Bias: 8 V
- Input & Output Matched: 50 Ω
- Die Size: 3650 x 1260 x 100 μm
- RoHS* Compliant

Applications

- Radar
- SATCOM

Description

The MAAL-011251-DIE is a very low noise 3 stage LNA designed to operate from 24 to 34 GHz with 1.6 dB of noise figure and 18 dB of gain and is offered in bare die form. It is fully matched across the frequency band.

The MAAL-011251-DIE has a single positive and single negative voltage bias which includes a DC current regulation. This LNA is matched to 50 Ω at both input and output ports. This device is ideally suited to satellite communication and radar applications.

The MAAL-011251-DIE is manufactured using a high performance 100 nm gate length GaN on Si HEMT power technology (D01GH). The MMIC uses gold bonding pads and backside metallization and is fully protected with silicon nitride passivation to obtain the highest level of reliability.

Block Diagram

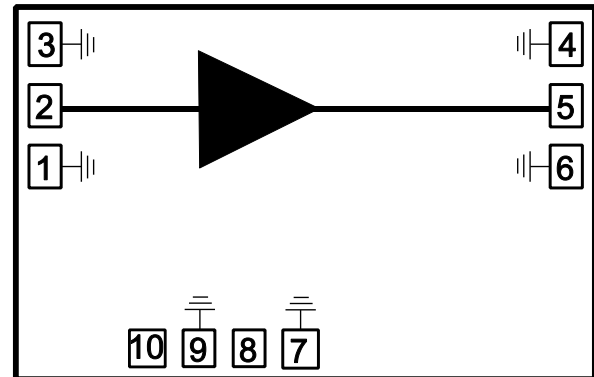

Pad Configuration

Pad #	Function	Function
1,3,4,6,7,9	GND	Ground
2	RF _{IN}	RF Input
5	RF _{OUT}	RF Output
8	V _D	Voltage Drain
10	V _S	Negative voltage

Ordering Information

Part Number	Package
MAAL-011251-DIE	DIE
MAAL-011251-SB2	Evaluation Board

* Restrictions on Hazardous Substances, compliant to current RoHS EU directive.

Electrical Specifications: Freq. = 24 - 34 GHz, $V_D = 8\text{ V}$, $T_A = +25^\circ\text{C}$

Parameter	Test Conditions	Units	Min.	Typ.	Max.
Noise Figure	At nominal conditions	dB	—	1.6	2.1
Gain	At nominal conditions	dB	15	18	—
Output P1dB	At nominal conditions	dBm	—	5	—
Input Return Loss	At nominal conditions	dB	—	-11	—
Output Return Loss	At nominal conditions	dB	—	-12	—
Current	Total DC current included DC current regulation	mA	—	50	—

Recommended Operating Conditions

Parameter	Unit
DC Supply V_S	-3 V
DC Supply V_D	+8 V

Absolute Maximum Ratings^{1,2,3,4}

Parameter	Absolute Maximum
Input RF ports	30 dBm
DC Voltage Drain Supply	12 V
Junction Temperature ^{7,8}	+200°C
Operating Temperature	-40°C to +85°C
Storage Temperature	-40°C to +150°C

Handling Procedures

Please observe the following precautions to avoid damage:

Static Sensitivity

These electronic devices are sensitive to electrostatic discharge (ESD) and can be damaged by static electricity. Proper ESD control techniques should be used when handling these devices.

1. Exceeding any one or combination of these limits may cause permanent damage to this device.
2. MACOM does not recommend sustained operation near these survivability limits.
3. Operating at nominal conditions with $T_J \leq +150^\circ\text{C}$ will ensure $\text{MTTF} > 1 \times 10^{11}$ hours.
4. Junction Temperature (T_J) = $T_C + \Theta_{jc} * (V * I)$
 Typical thermal resistance (Θ_{jc}) = 32.5°C/W.
 a) For $T_C = +85^\circ\text{C}$,
 $T_J = 125^\circ\text{C} @ 8\text{ V}, 150\text{ mA}$

Typical Performance Curves @ $T_c = 25^\circ\text{C}$ in wafer: S-Parameters with 0.1 nH assumed Wirebond

Noise Figure over Frequency

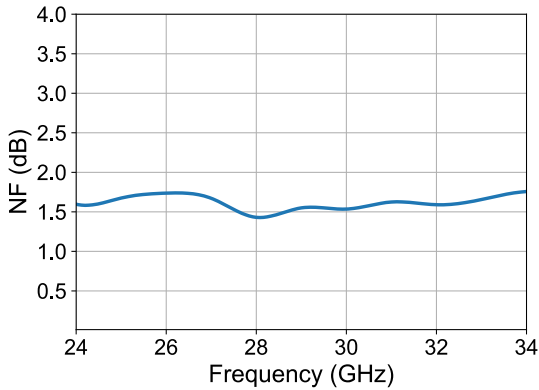

Gain over Frequency

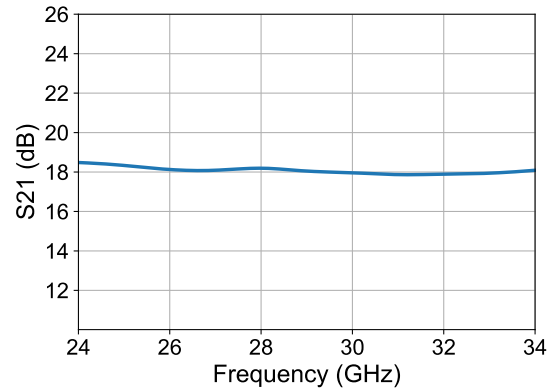

Input Return Loss over Frequency

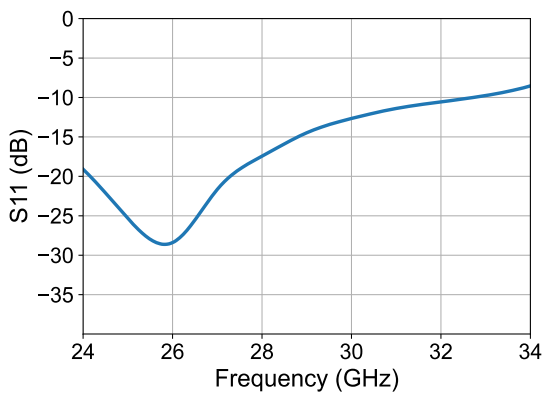

Output Return Loss over Frequency

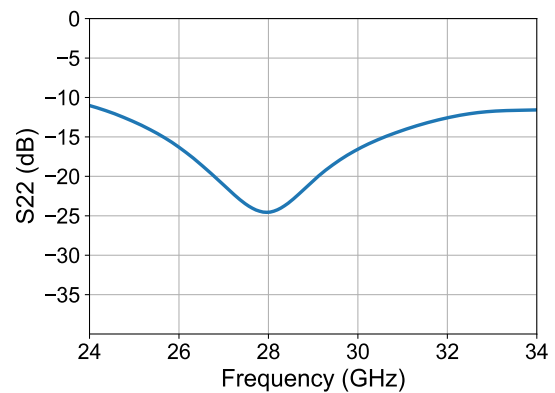

Output P1dB over Frequency at different current

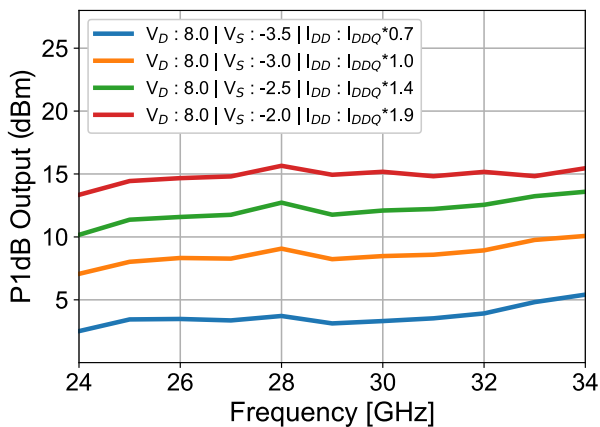

Typical Performance Curves In board @ $T_C = 25^\circ\text{C}$ with De-Embedding at different temperature: S-Parameters in CW at PCB level with De-Embedding

Noise Figure over Frequency

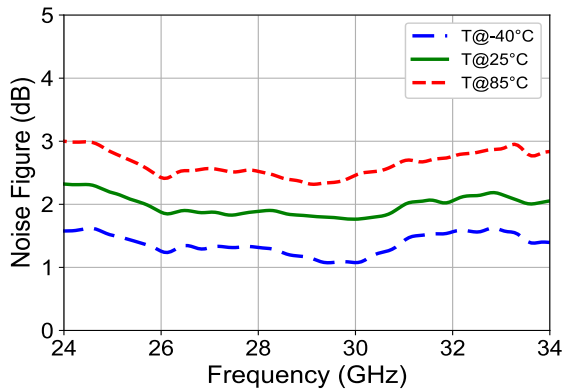

Gain over Frequency

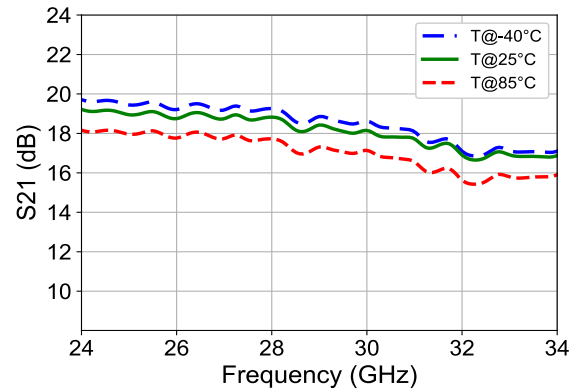

Input Return Loss over Frequency

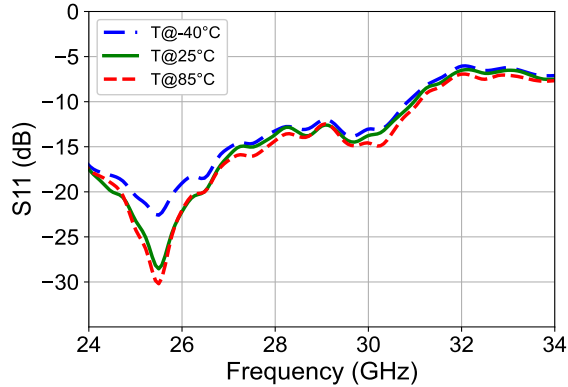

Output Return Loss over Frequency

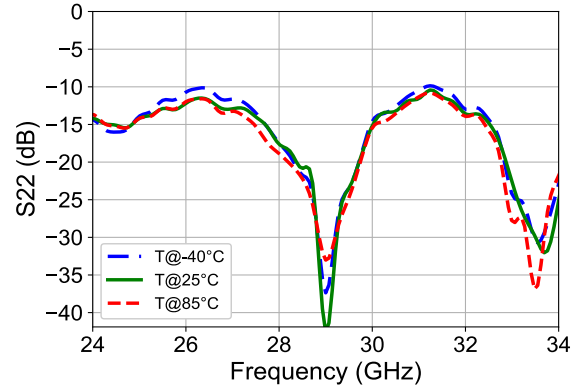

Typical Performance Curves In Board @ $T_c = 25^\circ\text{C}$ with De-Embedding at different temperature

Output power over Input power

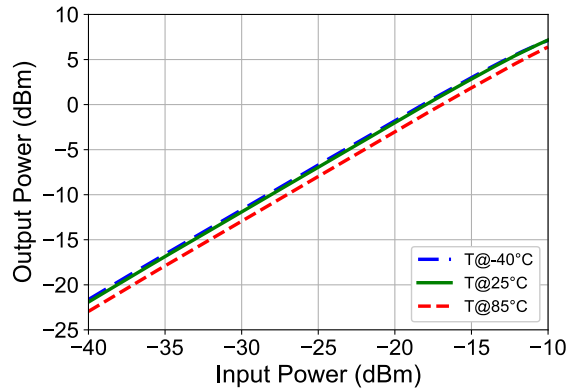

IM3 over Input power

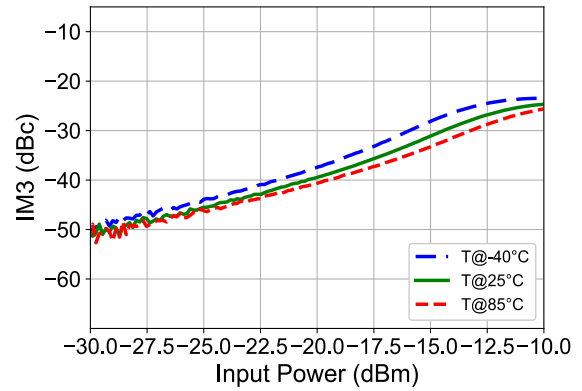

RF access line & connector Losses over Frequency

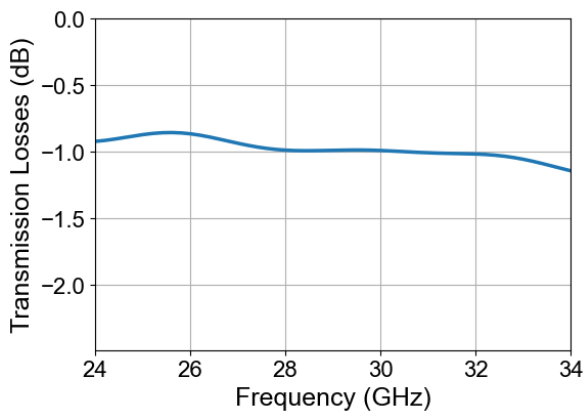

Recommended Bonding Diagram

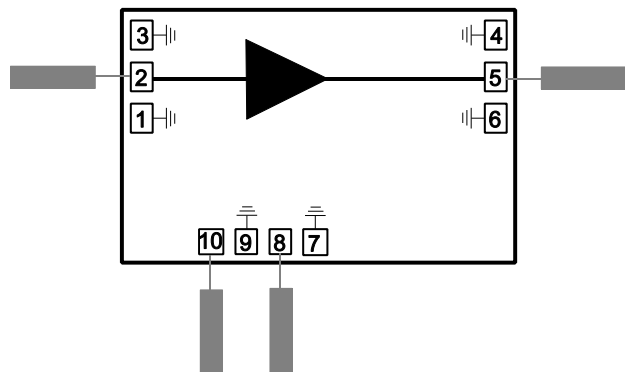

Functional Schematic

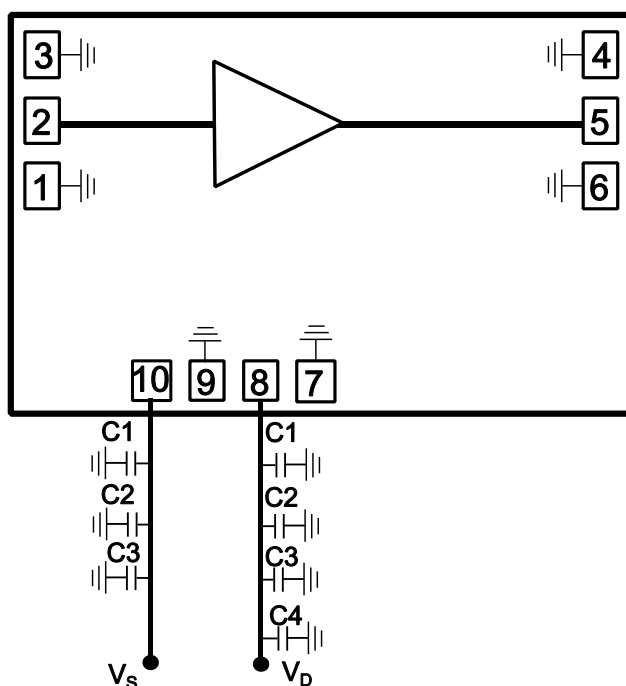

Parts List

Part	Value	Case Style	Manufacturer	Type	Manufacturer's Part #
C1	47pF	0.381 mm	KYOCERA AVX	Single layer capacitor	116RG470M100TT
C2	100pF	1005 mm	YAGEO	SMD Multi Layer Capacitor	223891811536
C3	10nF	1005 mm	KYOCERA AVX	SMD Multi Layer Capacitor	0402YC103KAT2A
C4	1 μ F	1005 mm	Murata	SMD Multi Layer Capacitor	GRM155R70G105KA12D

Die Outline (mm)

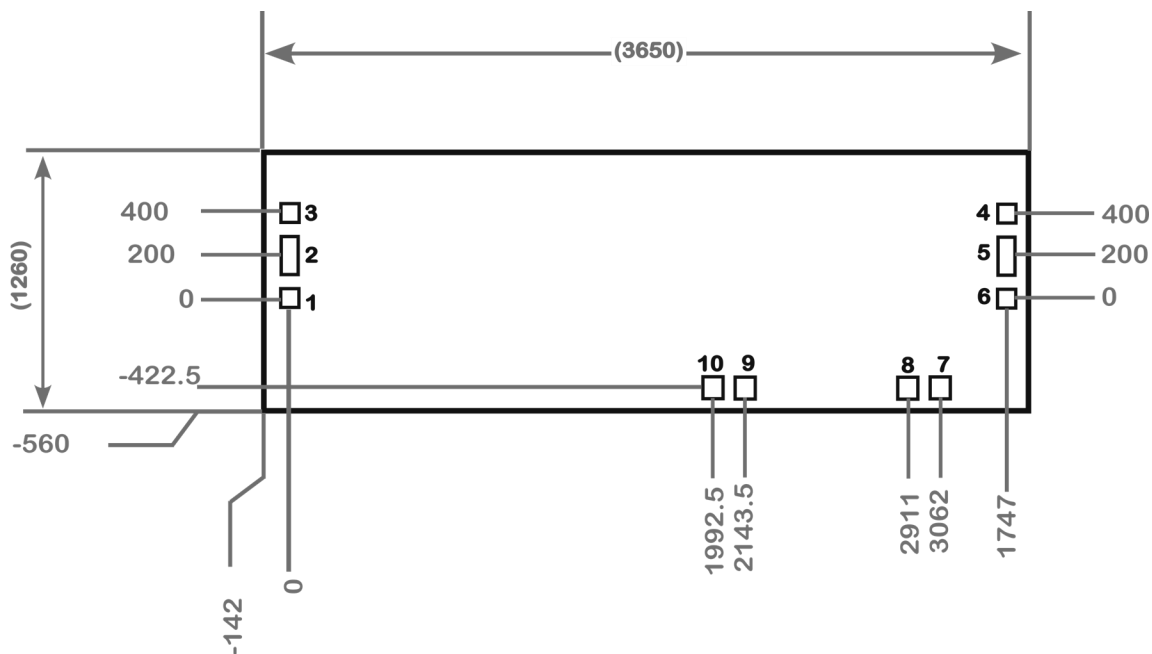

PADs Dimensions (µm)

Pad #	X	Y
1,3,4,6	93	93
2,5	93	193
7,8,9,10	97	107

Revision History

Rev	Date	Change description
V1	12/29/23	PTRR
V2	12/03/24	Production Release

MACOM Technology Solutions Inc. ("MACOM"). All rights reserved.

These materials are provided in connection with MACOM's products as a service to its customers and may be used for informational purposes only. Except as provided in its Terms and Conditions of Sale or any separate agreement, MACOM assumes no liability or responsibility whatsoever, including for (i) errors or omissions in these materials; (ii) failure to update these materials; or (iii) conflicts or incompatibilities arising from future changes to specifications and product descriptions, which MACOM may make at any time, without notice. These materials grant no license, express or implied, to any intellectual property rights.

THESE MATERIALS ARE PROVIDED "AS IS" WITH NO WARRANTY OR LIABILITY, EXPRESS OR IMPLIED, RELATING TO SALE AND/OR USE OF MACOM PRODUCTS INCLUDING FITNESS FOR A PARTICULAR PURPOSE, MERCHANTABILITY, INFRINGEMENT OF INTELLECTUAL PROPERTY RIGHT, ACCURACY OR COMPLETENESS, OR SPECIAL, INDIRECT, INCIDENTAL, OR CONSEQUENTIAL DAMAGES WHICH MAY RESULT FROM USE OF THESE MATERIALS.

MACOM products are not intended for use in medical, lifesaving or life sustaining applications. MACOM customers using or selling MACOM products for use in such applications do so at their own risk and agree to fully indemnify MACOM for any damages resulting from such improper use or sale.