

Dual Low Noise Amplifier

17.25 - 21.50 GHz



MAAL-011146

Rev. V1

Features

- 17 dB Small Signal Gain
- 1.4 dB Noise Figure
- Single 2 V Bias
- Lead-Free 3 mm 16-Lead PQFN Package
- RoHS* Compliant

Applications

- ISM
- Multi Market

Description

The MAAL-011146 is a dual channel low noise amplifier. This device has a small signal gain of 17 dB with a noise figure of 1.4 dB.

This lead-free, 3 mm QFN package requires only a single positive bias supply.

The device is well suited to multiple receiver applications which require high performance with simple bias requirements and the ease of volume manufacturing with 3 mm QFN packaging.

All data shown measured on an evaluation board with thru losses subtracted out (de-embedded).

Functional Block Diagram

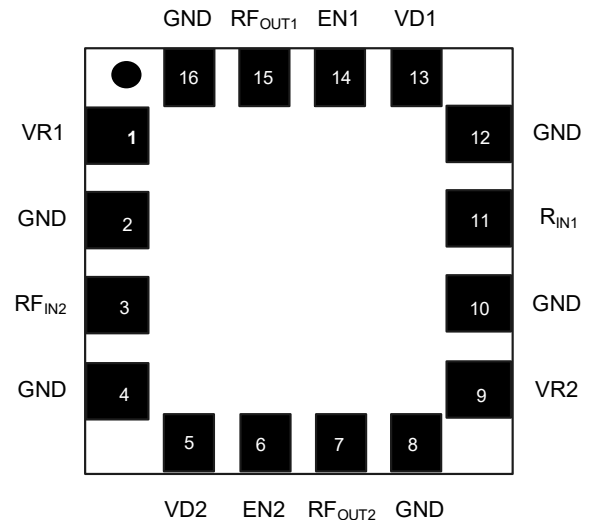

Pin Configuration

Pin #	Pin Name	Description
1	VR1	Bias Control CH1
2,4,8,10,12,16	GND	Ground
3	RF _{IN2}	RF Input CH2
5	VD2	Supply CH2
6	EN2	Enable CH2
7	RF _{out2}	RF Output CH2
9	VR2	Bias Control CH2
11	RF _{IN1}	RF Input CH1
13	VD1	Supply CH1
14	EN1	Enable CH1
15	RF _{out1}	RF Output CH1
Paddle ²		RF and DC Ground

Ordering Information¹

Part Number	Package
MAAL-011146-TR1000	1000 piece reel
MAAL-011146-SMB	Sample Board

1. Reference Application Note M513 for reel size information.

2. The exposed pad centered on the package bottom must be connected to RF and DC ground.

¹ * Restrictions on Hazardous Substances, compliant to current RoHS EU directive.

Dual Low Noise Amplifier

17.25 - 21.50 GHz



MAAL-011146

Rev. V1

Electrical Specifications: Freq: 17.25 - 21.50 GHz, $V_D = 2\text{ V}$, $T_A = +25^\circ\text{C}$

Parameter	Test Conditions	Units	Min.	Typ.	Max.
Small Signal Gain	17.25 GHz 19.00 GHz 21.50 GHz	dB	16 16 14	19 19 17	—
Gain Flatness	—	dB	—	2	—
Noise Figure	—	dB	—	1.4	2.0
Input Return Loss	—	dB	—	10	—
Output Return Loss	—	dB	—	15	—
Reverse isolation	—	dB	—	30	—
Individual channel isolation when disabled	Defined as channel S21 when in disabled state	dB	—	20	—
Channel to Channel Isolation - Both Enabled One Enabled	Both Channels are ON Channel 2 is OFF	dB	—	35 35	—
Output P1dB	—	dBm	—	12	—
Supply Current (I_D)	—	mA	—	30	45

3. Measure output power at channel 2 output and calculating the coupling factor referenced to channel 1 output.

Absolute Maximum Ratings^{3,4}

Parameter	Absolute Max.
Supply Voltage	3.3 VDC
Supply Current	70 mA
Input Power	12.0 dBm
Storage Temperature	-65°C to +165°C
Operating Temperature	-40°C to +85°C
Channel Temperature ^{5,6}	+150°C

3. Exceeding any one or combination of these limits may cause permanent damage to this device.
4. MACOM does not recommend sustained operation near these survivability limits.
5. Operating at nominal conditions with $T_J \leq +150^\circ\text{C}$ will ensure $\text{MTTF} > 1 \times 10^6$ hours
6. Junction Temperature (T_J) = $T_C + \Theta_{jc} * (V * I)$
 Typical thermal resistance (Θ_{jc}) = 57 °C/W.
 - a) For $T_C = +25^\circ\text{C}$,
 $T_J = 29^\circ\text{C} @ 2 \text{ V}, 35 \text{ mA}$
 - b) For $T_C = +85^\circ\text{C}$,
 $T_J = 84^\circ\text{C} @ 2 \text{ V}, 35 \text{ mA}$

Enable Pin Logic Levels^{7,8}

Parameter	Function	Voltage Range
Logic Low	Shut down	0 V to 0.68 V
Logic High	Enable	1.07 V to 2.2V

7. Conforms with EIA/JEDEC 8-7 (1.8 V) logic levels.

8. Each Enable Pin sinks < 100 μA of current.

Handling Procedures

Please observe the following precautions to avoid damage:

Static Sensitivity

Gallium Arsenide Integrated Circuits are sensitive to electrostatic discharge (ESD) and can be damaged by static electricity. Proper ESD control techniques should be used when handling these Class 1A devices.

Application Schematic

Adjust Rbias for desired bias current. Place C2 and C3 as close as physically possible to the package. The location for C1 and C4 is not critical.

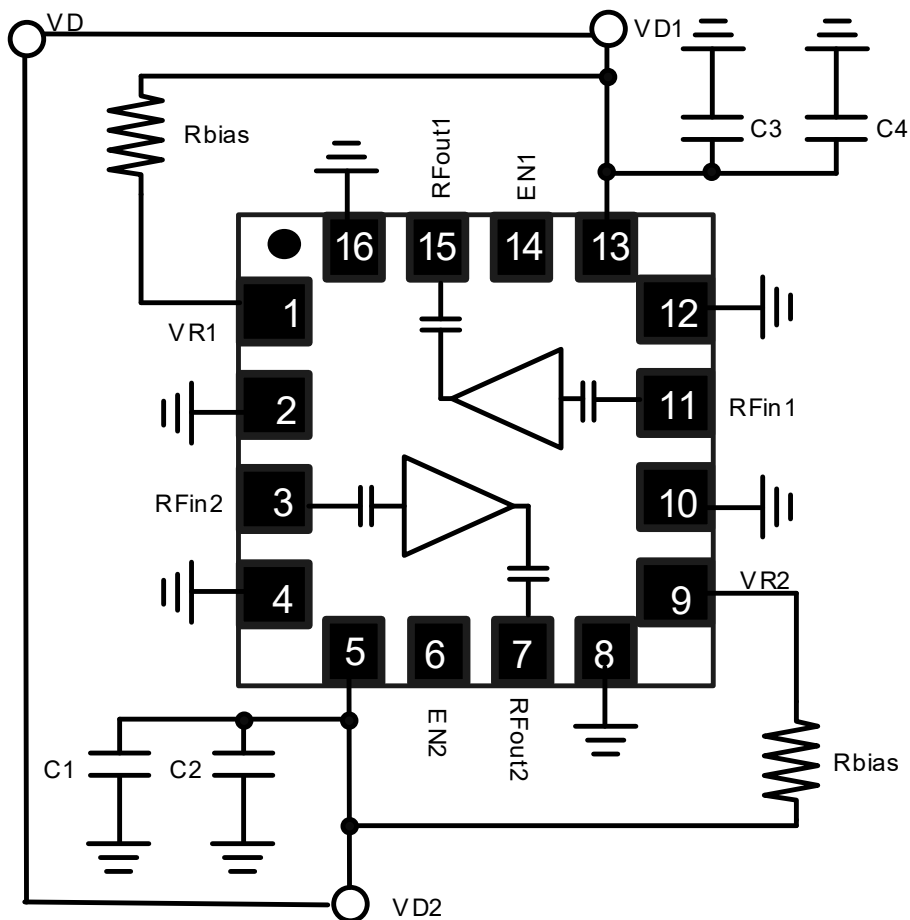

Device	Value
Rbias	Set for desired bias current
C1, C4	0.1 μ F
C2, C3	100 pF

Dual Low Noise Amplifier

17.25 - 21.50 GHz



MAAL-011146

Rev. V1

Typical Performance Curves CH1: $V_D = 2.5\text{ V}$, $I_D = 30\text{ mA}$

Gain

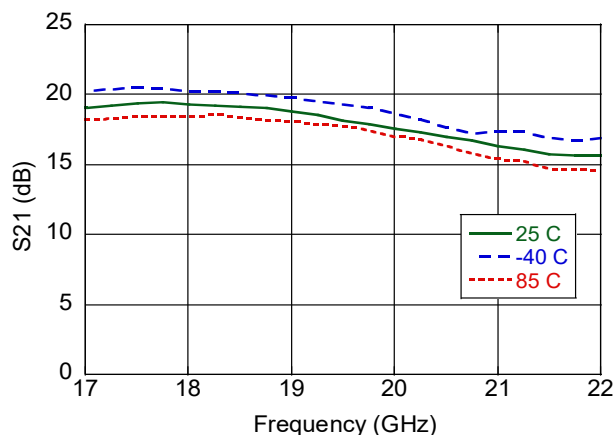

Input Return Loss

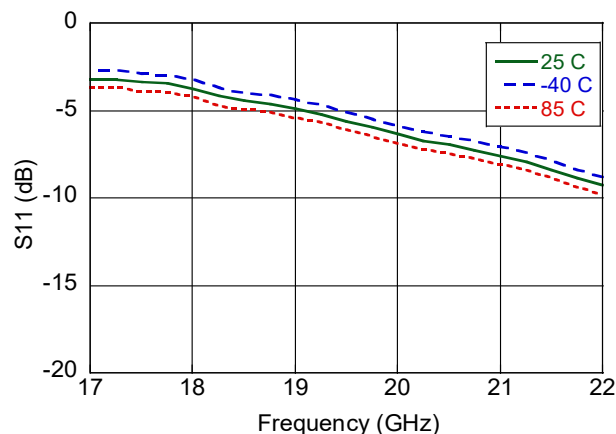

Output Return Loss

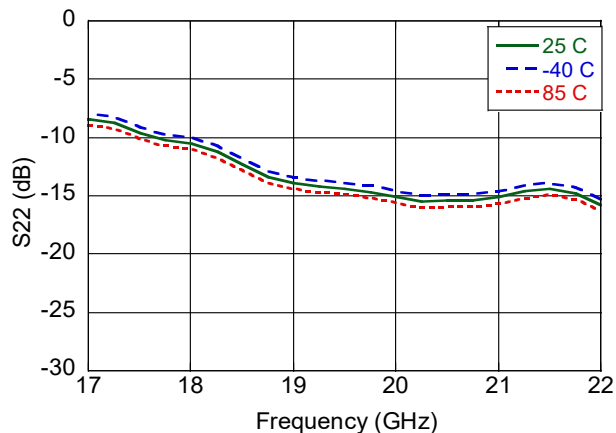

Reverse Isolation

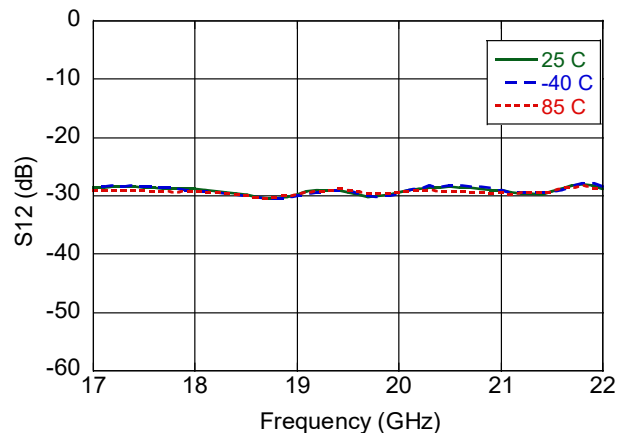

P1dB

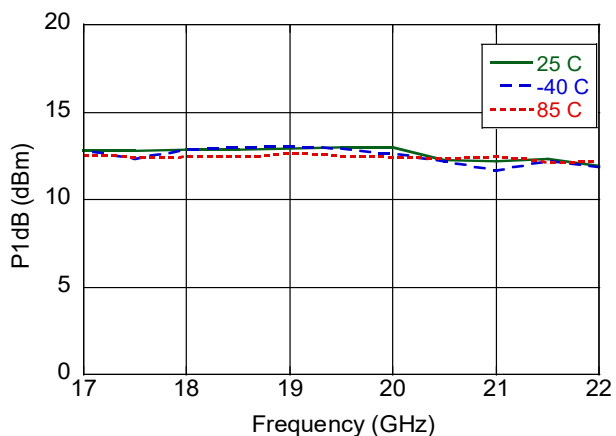

P3dB

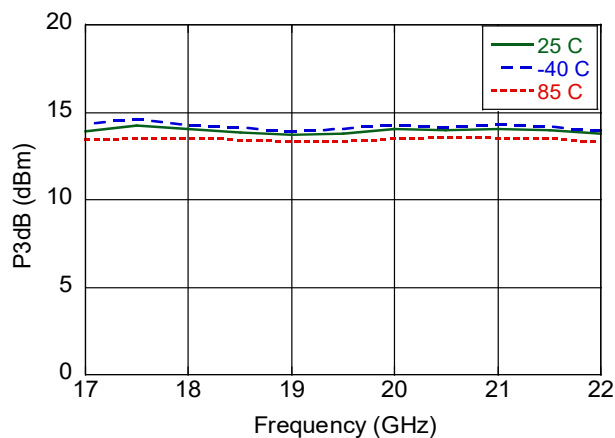

Typical Performance Curves CH2: $V_D = 2.5\text{ V}$, $I_D = 30\text{ mA}$

Gain

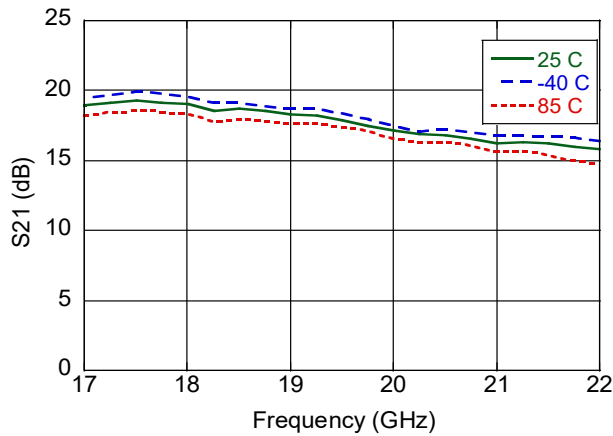

Input Return Loss

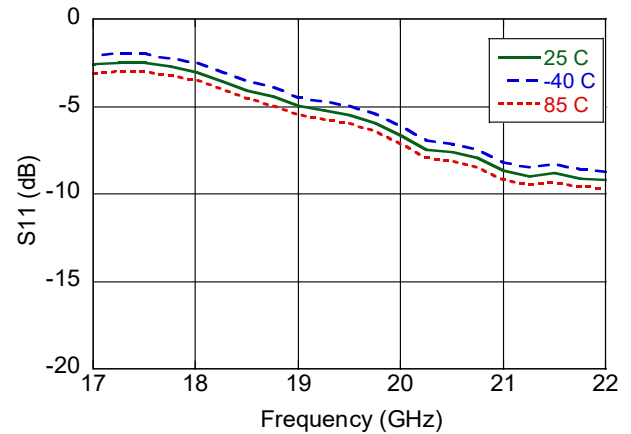

Output Return Loss

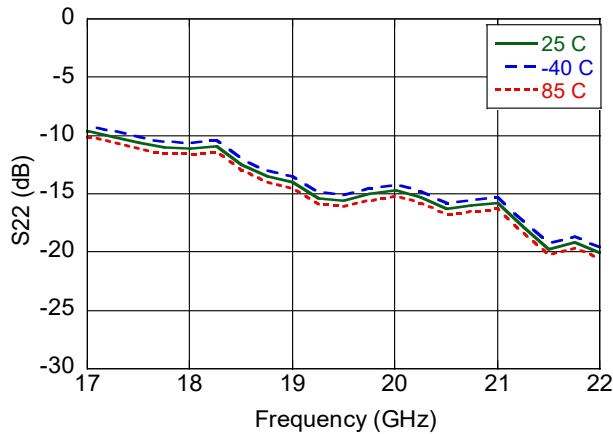

Reverse Isolation

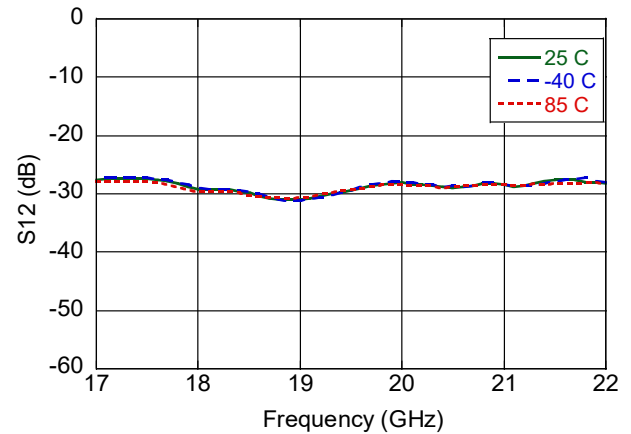

P1dB

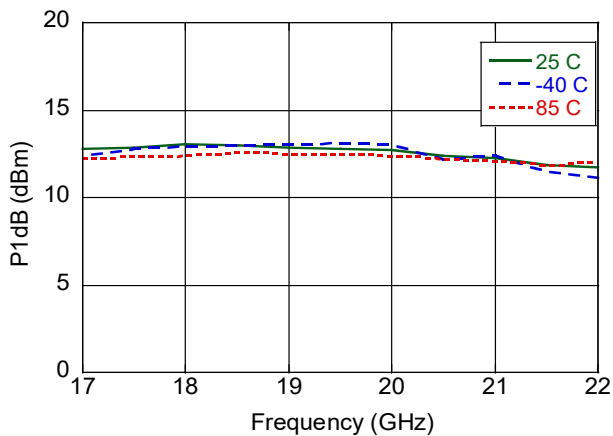

P3dB

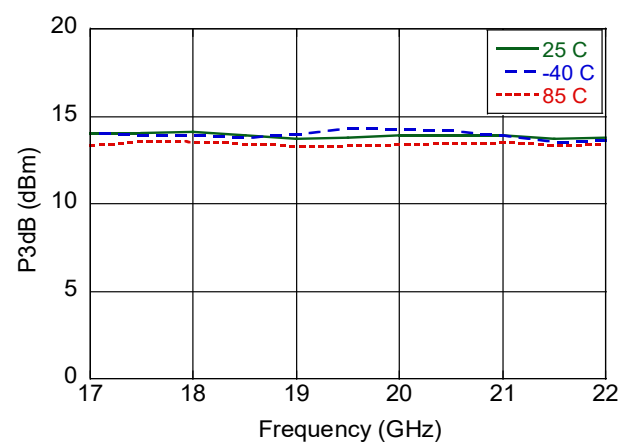

Dual Low Noise Amplifier

17.25 - 21.50 GHz



MAAL-011146

Rev. V1

Typical Performance Curves CH1: $I_D = 30 \text{ mA}$, $+25^\circ\text{C}$

Gain

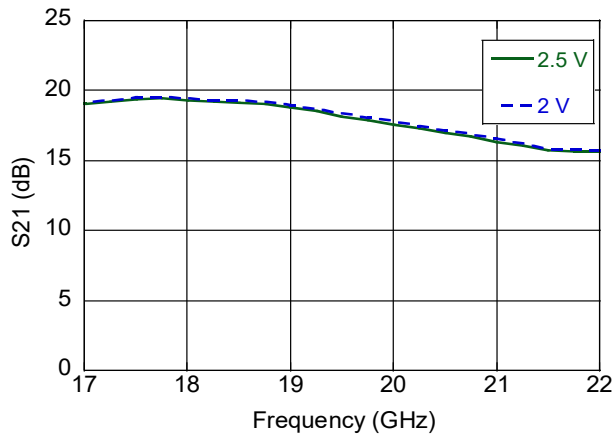

Input Return Loss

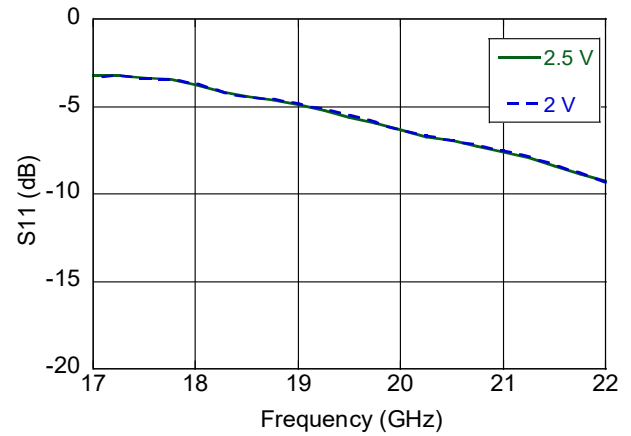

Output Return Loss

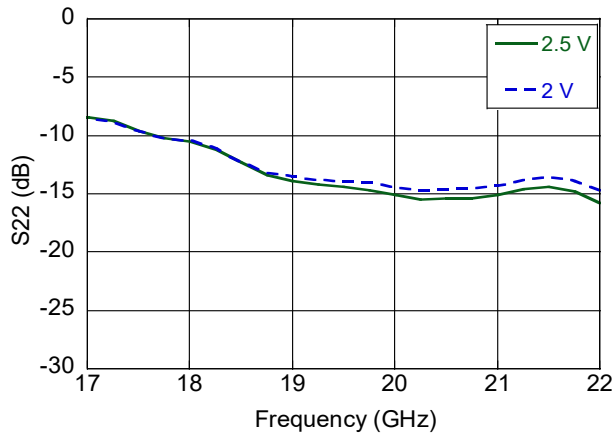

Reverse Isolation

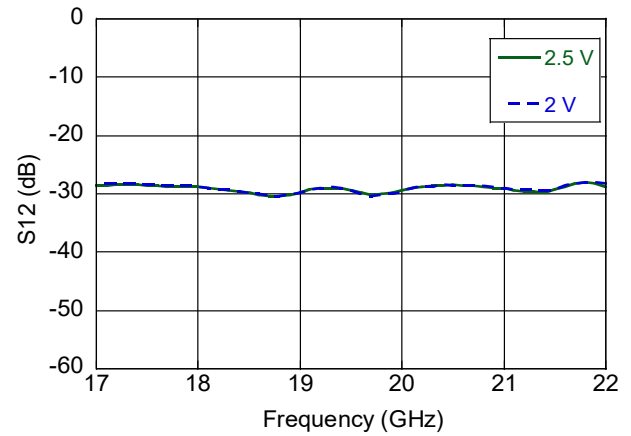

P1dB

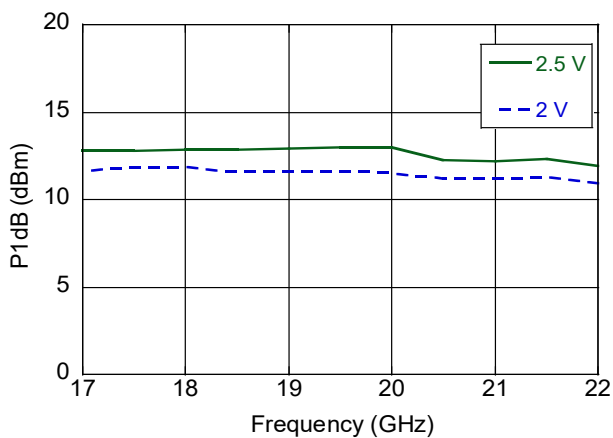

P3dB

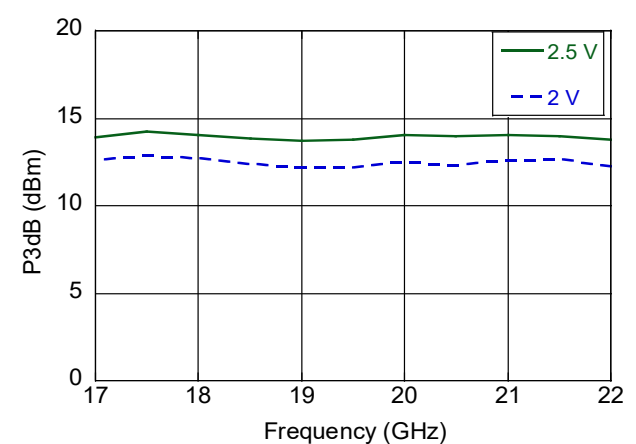

Dual Low Noise Amplifier

17.25 - 21.50 GHz



MAAL-011146

Rev. V1

Typical Performance Curves CH2: $I_D = 30 \text{ mA}$, $+25^\circ\text{C}$

Gain

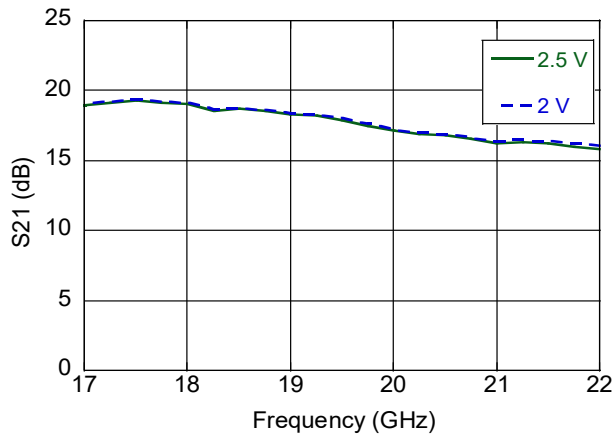

Input Return Loss

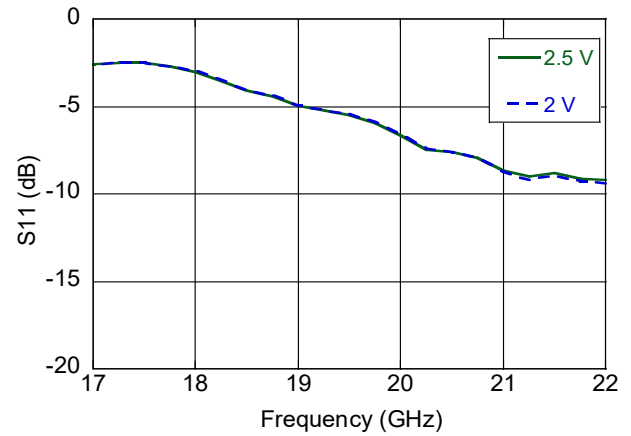

Output Return Loss

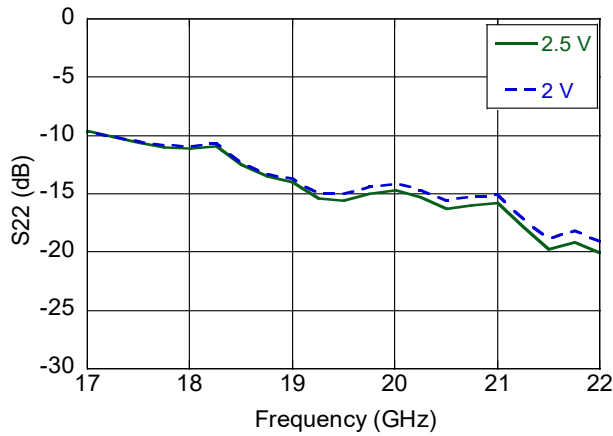

Reverse Isolation

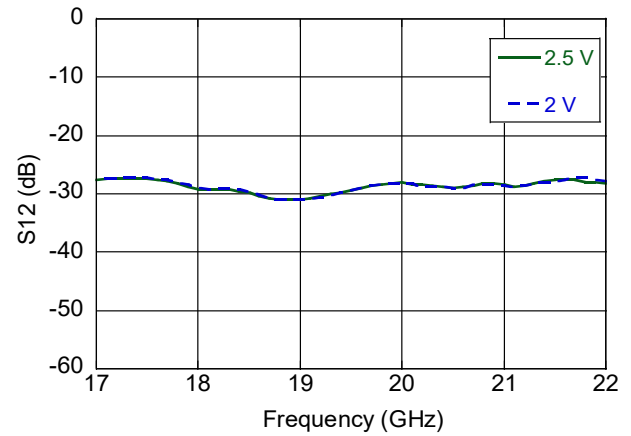

P1dB

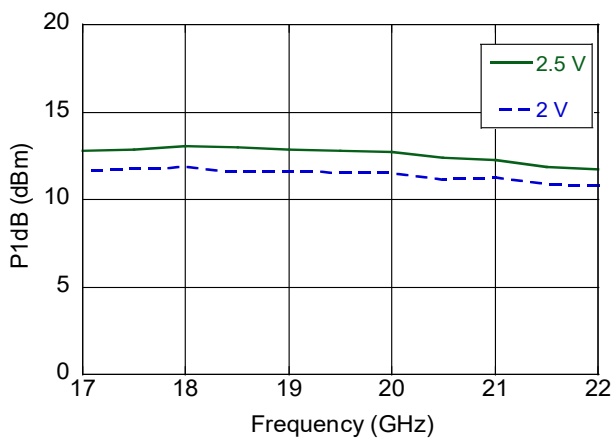

P3dB

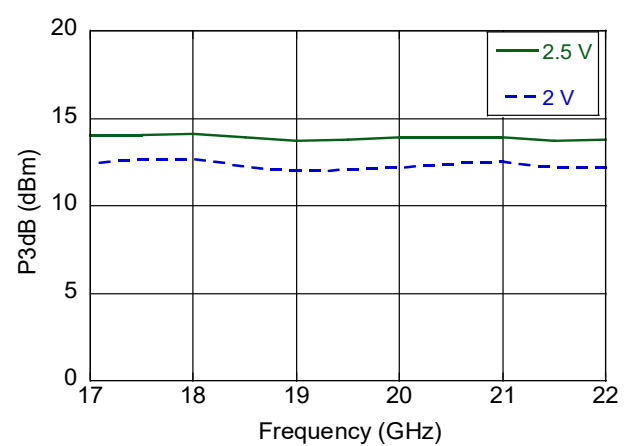

Typical Performance Curves CH1: $V_D = 2.5\text{ V}$, $+25^\circ\text{C}$

Gain

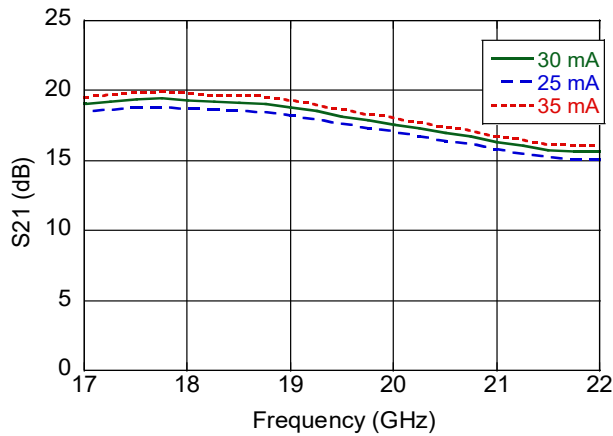

Input Return Loss

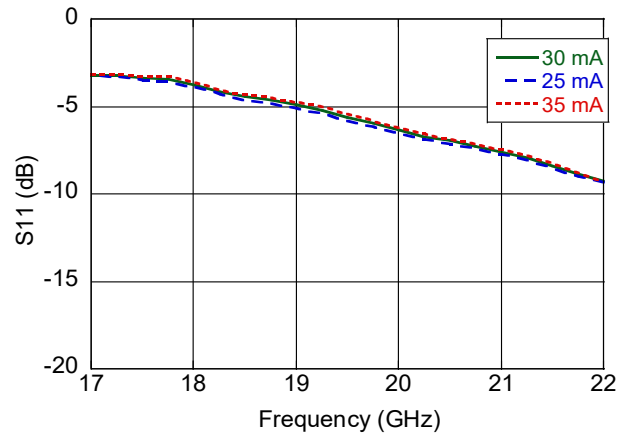

Output Return Loss

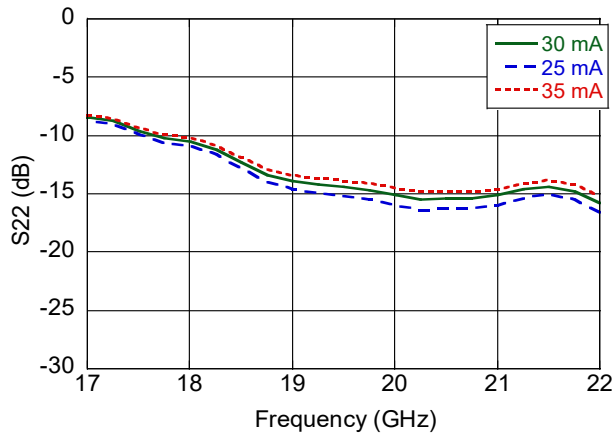

Reverse Isolation

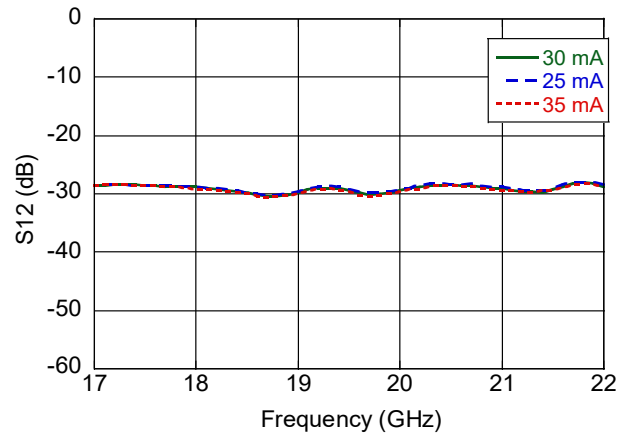

P1dB

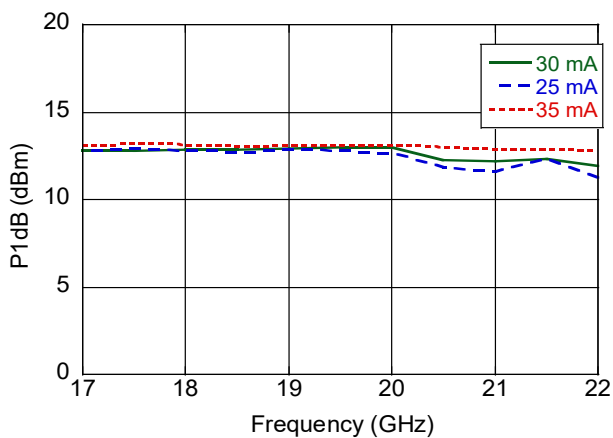

P3dB

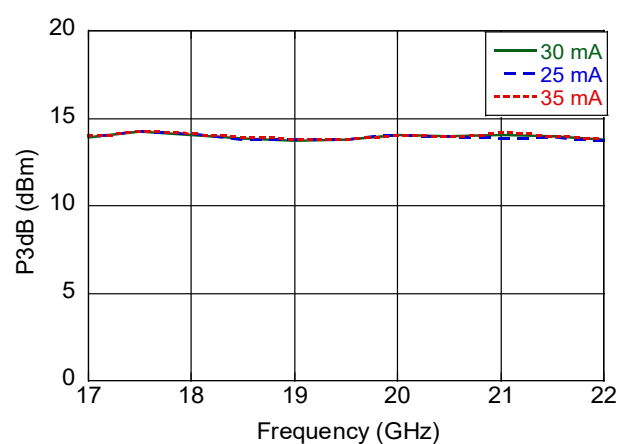

Typical Performance Curves CH2: $V_D = 2.5\text{ V}$, $+25^\circ\text{C}$

Gain

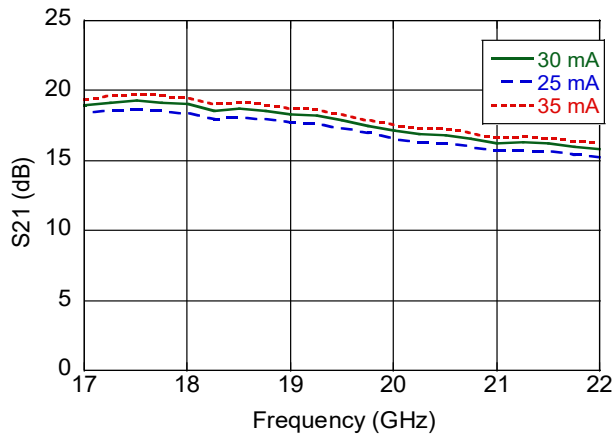

Input Return Loss

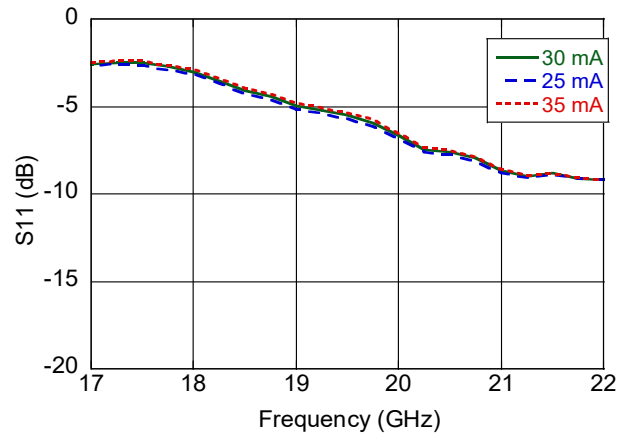

Output Return Loss

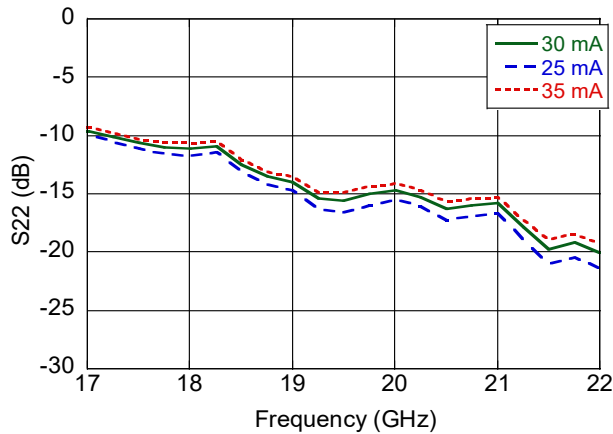

Reverse Isolation

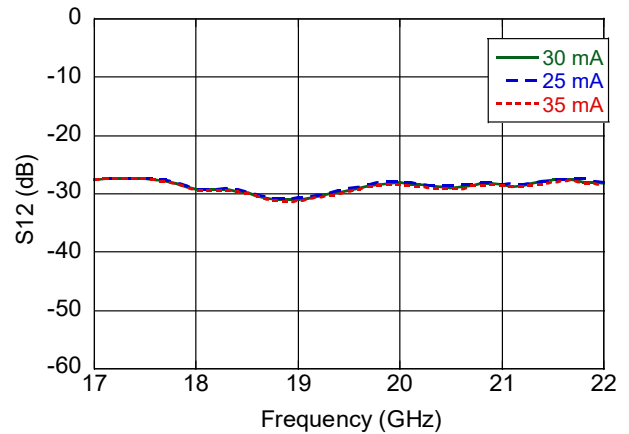

P1dB

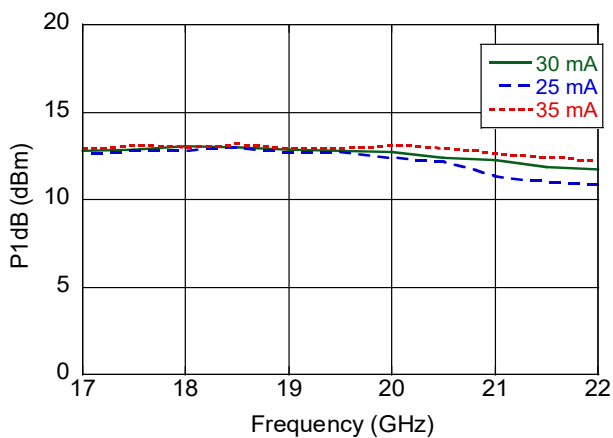

P3dB

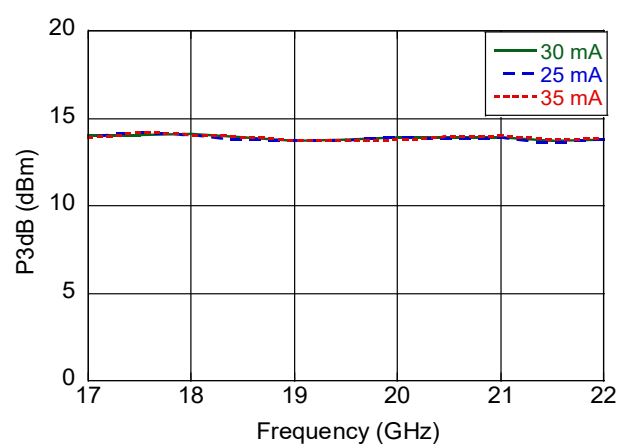

Dual Low Noise Amplifier

17.25 - 21.50 GHz



MAAL-011146

Rev. V1

Typical Performance Curves CH1: $V_D = 2.5\text{ V}$, $I_D = 30\text{ mA}$, $+25^\circ\text{C}$

Output IP3 @ $P_{in} = -15\text{ dBm}$ per tone

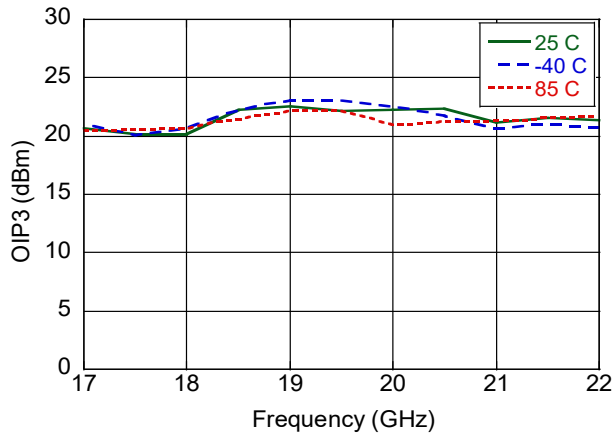

Noise Figure

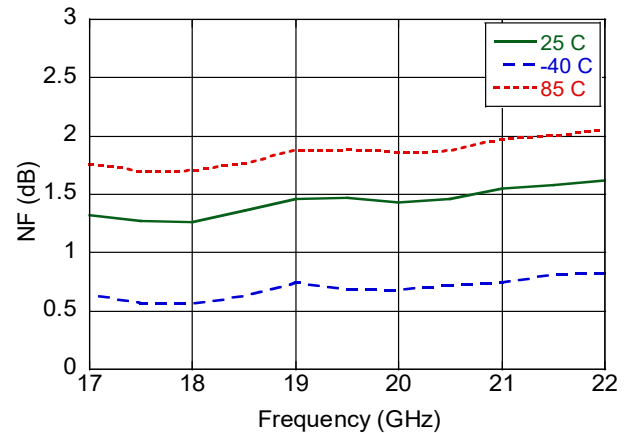

Output IP3 @ $P_{in} = -15\text{ dBm}$ per tone

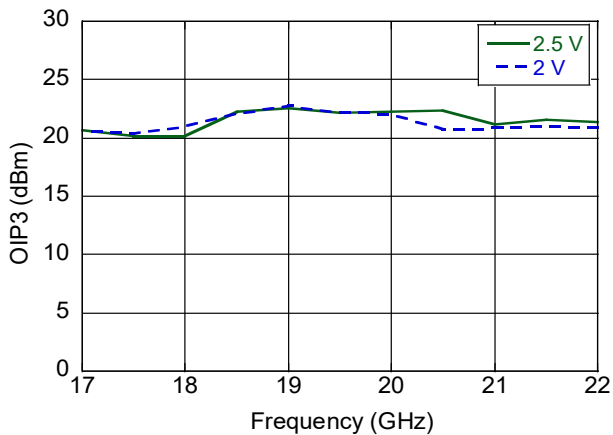

Noise Figure

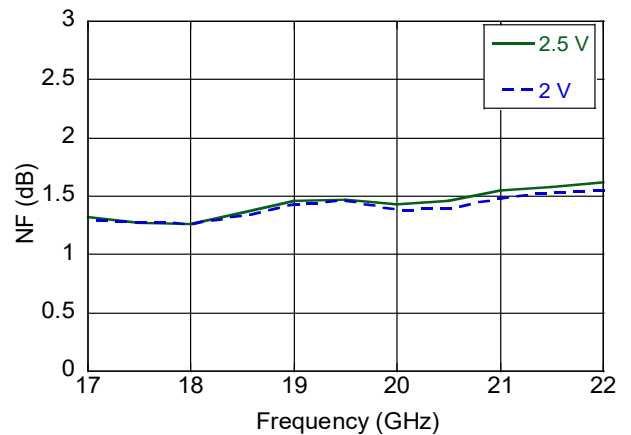

Output IP3 @ $P_{in} = -15\text{ dBm}$ per tone

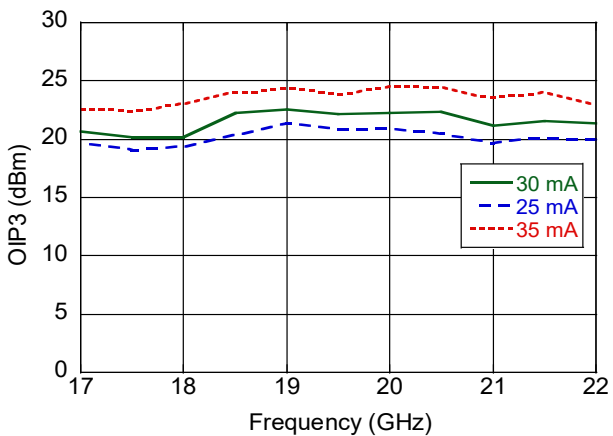

Noise Figure

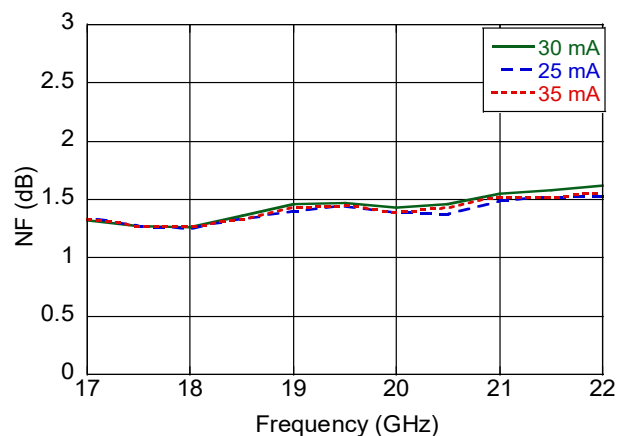

Dual Low Noise Amplifier

17.25 - 21.50 GHz



MAAL-011146

Rev. V1

Typical Performance Curves CH2: $V_D = 2.5\text{ V}$, $I_D = 30\text{ mA}$, $+25^\circ\text{C}$

Output IP3 @ $P_{in} = -15\text{ dBm}$ per tone

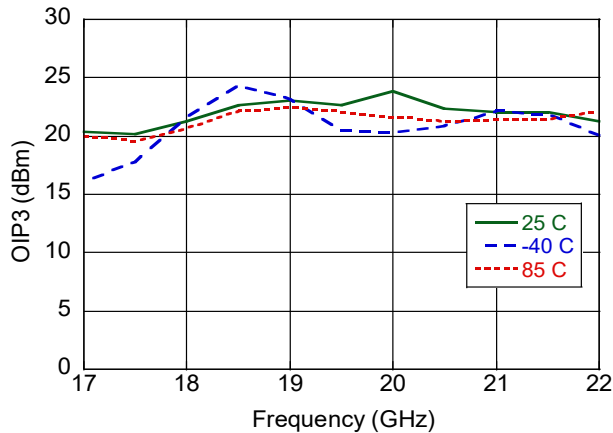

Noise Figure

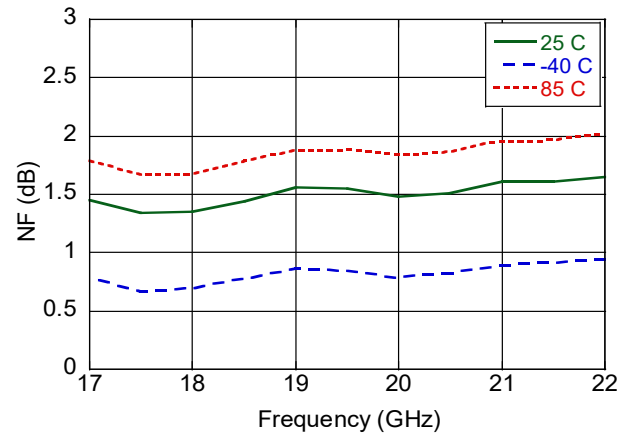

Output IP3 @ $P_{in} = -15\text{ dBm}$ per tone

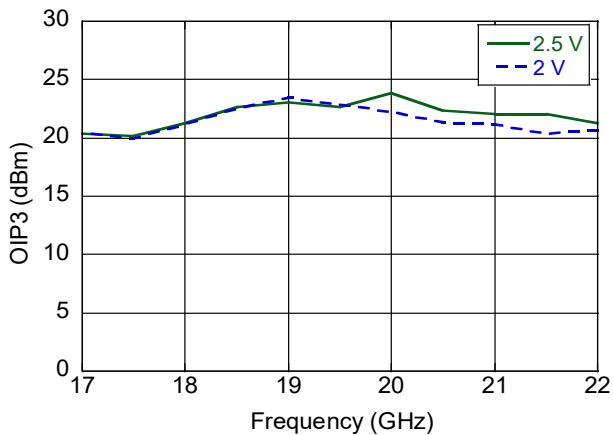

Noise Figure

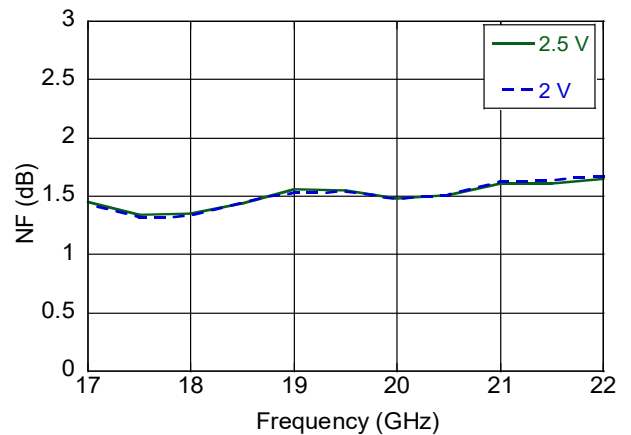

Output IP3 @ $P_{in} = -15\text{ dBm}$ per tone

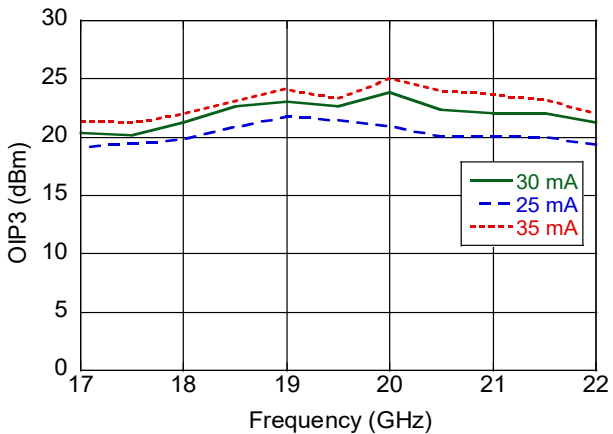

Noise Figure

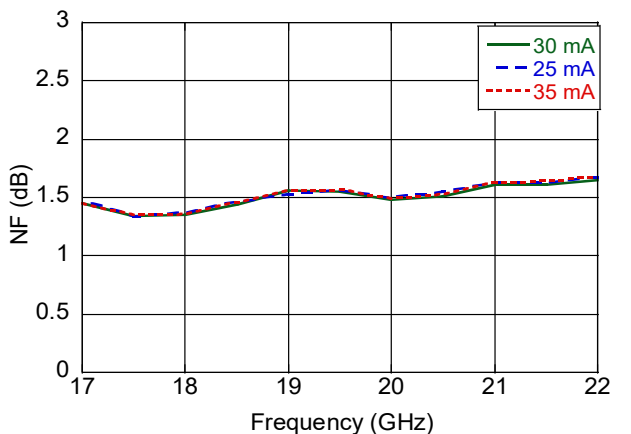

Evaluation Board Thru Losses Including Edge Connectors

Combined Input and Output Thru Loss

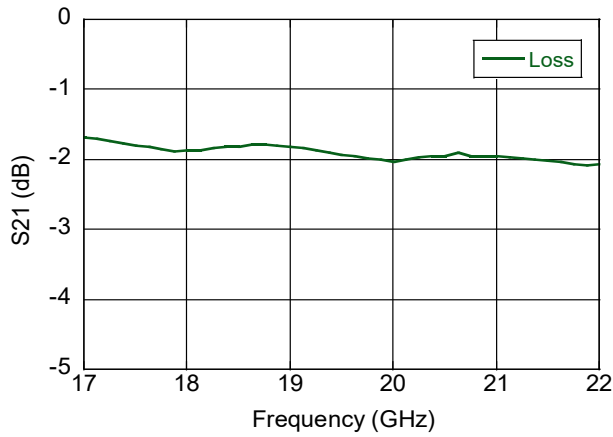

Dual Low Noise Amplifier

17.25 - 21.50 GHz



MAAL-011146

Rev. V1

Lead-Free 3 mm 16-Lead PQFN[†]

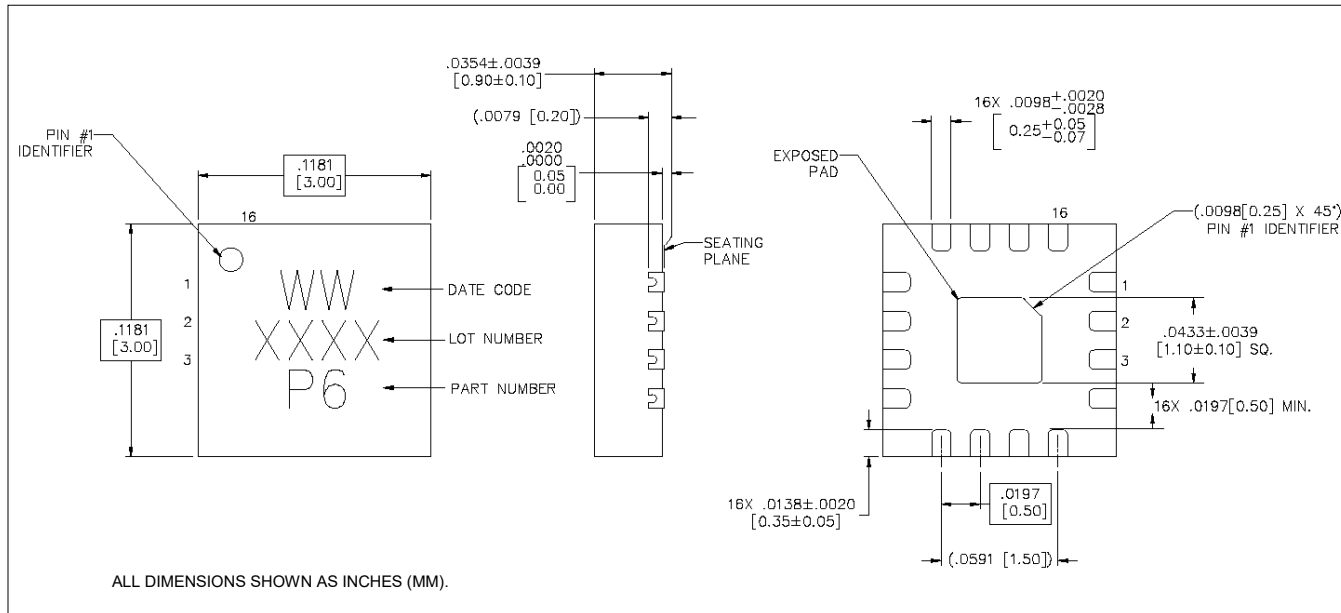

[†] Reference Application Note S2083 for lead-free solder reflow recommendations.
 Meets JEDEC moisture sensitivity level 1 requirements.
 Plating is NiPdAuAg plating over copper

MACOM Technology Solutions Inc. ("MACOM"). All rights reserved.

These materials are provided in connection with MACOM's products as a service to its customers and may be used for informational purposes only. Except as provided in its Terms and Conditions of Sale or any separate agreement, MACOM assumes no liability or responsibility whatsoever, including for (i) errors or omissions in these materials; (ii) failure to update these materials; or (iii) conflicts or incompatibilities arising from future changes to specifications and product descriptions, which MACOM may make at any time, without notice. These materials grant no license, express or implied, to any intellectual property rights.

THESE MATERIALS ARE PROVIDED "AS IS" WITH NO WARRANTY OR LIABILITY, EXPRESS OR IMPLIED, RELATING TO SALE AND/OR USE OF MACOM PRODUCTS INCLUDING FITNESS FOR A PARTICULAR PURPOSE, MERCHANTABILITY, INFRINGEMENT OF INTELLECTUAL PROPERTY RIGHT, ACCURACY OR COMPLETENESS, OR SPECIAL, INDIRECT, INCIDENTAL, OR CONSEQUENTIAL DAMAGES WHICH MAY RESULT FROM USE OF THESE MATERIALS.

MACOM products are not intended for use in medical, lifesaving or life sustaining applications. MACOM customers using or selling MACOM products for use in such applications do so at their own risk and agree to fully indemnify MACOM for any damages resulting from such improper use or sale.