

Low Power CMOS Transimpedance Amplifier with Rx Pwr Mon Output and AGC for Fiber Optic Networks up to 2.5 Gbps

Rev V6

Applications

- 2x Fiber Channel
- GPON
- PCI Express
- ATM/SONET
- Infiniband

Features

- Typical -26.2 dBm sensitivity, +6 dBm saturation at 2.125 Gbps, -26 dBm at 2.5 Gbps, when used with 0.9 A/W InGaAs PIN
- Typical Differential Transimpedance: 9 k Ω
- Fabricated in standard CMOS
- Differential output
- Standard +3.3 Volt supply
- Available in die form only
- Monitor output (SFF-8472 compliant)
- AGC provides dynamic range of 32 dB
- Internal or external bias for photodiode
- Usable with a PIN or APD photodiode
- Same pad layout and die size as M02011/13/14/16

The M02015 is a CMOS transimpedance amplifier with AGC. The AGC gives a wide dynamic range of 32 dB. The high transimpedance gain of 9 k Ω ensures good sensitivity.

For optimum system performance, the M02015 die should be mounted with a GaAs or InGaAs PIN photodetector inside a lensed TO-Can or other optical sub-assembly.

The M02015 can either bias the PIN diode from the internal regulator or use an externally biased PIN diode.

A replica of the average photodiode current is available at the MON pad for photo-alignment and Receive Power monitoring (SFF-8472 compliant).

Typical Applications Diagram

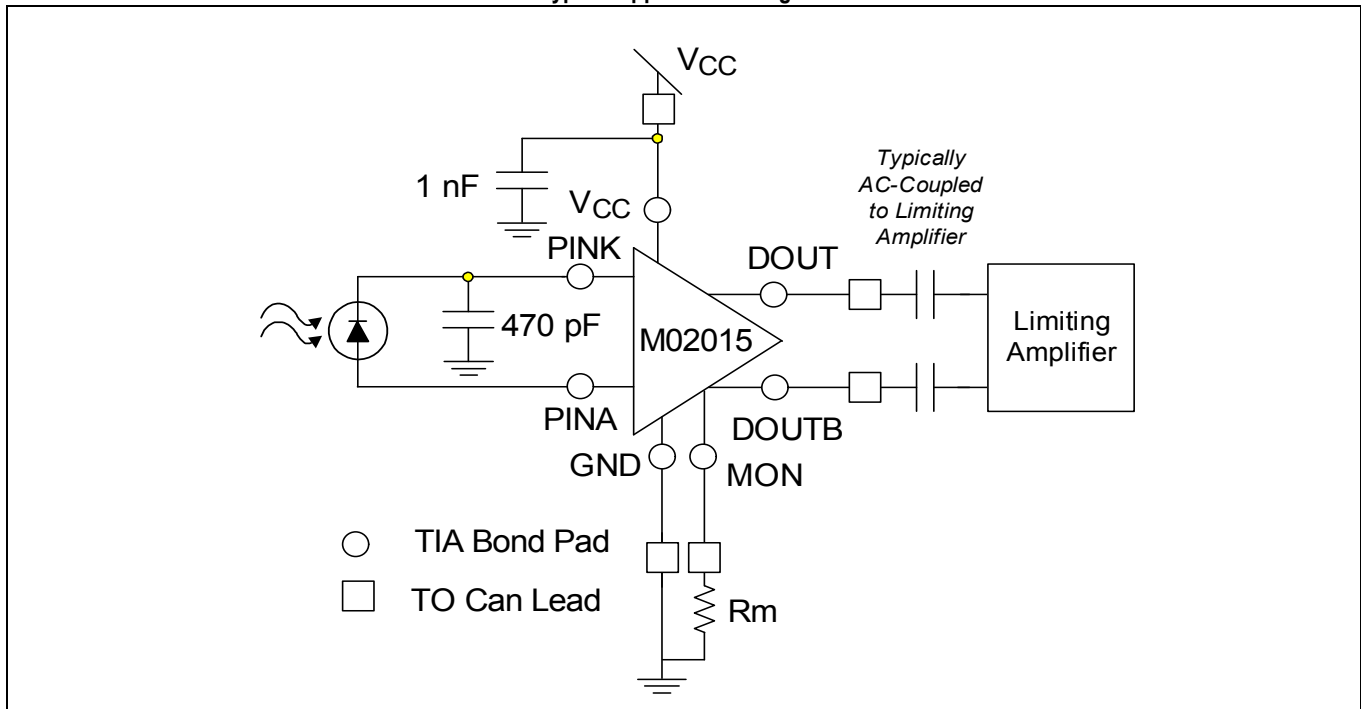

M/A-COM Technology Solutions Inc. (MACOM) and its affiliates reserve the right to make changes to the product(s) or information contained herein without notice. Visit www.macom.com for additional data sheets and product information.

Low Power CMOS Transimpedance Amplifier with Rx Pwr Mon Output and AGC for Fiber Optic Networks up to 2.5 Gbps Rev V6

Ordering Information

Part Number	Package	Operating Temperature
M02015-XX	Waffle Pack	-40 °C to 95 °C
M02015-XX	Expanded whole wafer on a ring	-40 °C to 95 °C

Revision History

Revision	Level	Date	Description
V6	Release	May 2015	Updated logos and page layout. No content changes.
H (V5)	Release	February 2014	Update Imon_off specification in Table 1-4
G (V4)	Release	August 2007	Corrected PinA, AGC, and DOUT absolute maximum voltage in Table 1-1 . Corrected Section 4.4 .
F (V3)	Release	December 2006	Corrected bottom picture in Figure 4-1 .
E (V2)	Release	October 2006	Updated the +/- signs on the x axis in the Die Specification (Chapter 5) and added notes to clarify the bonding requirements.

Pin Configuration

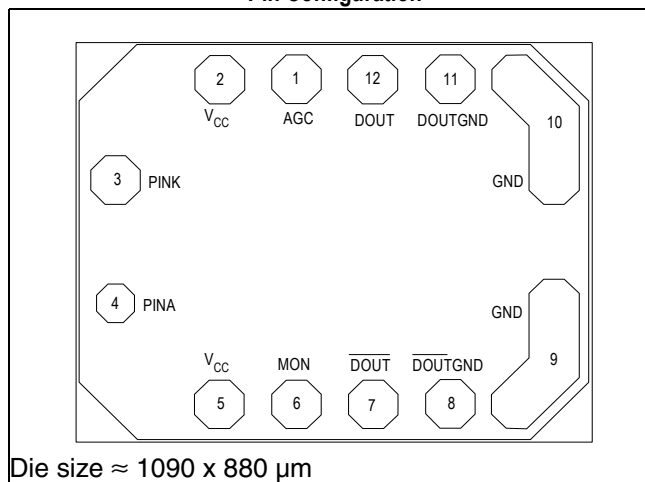

Typical Eye Diagrams

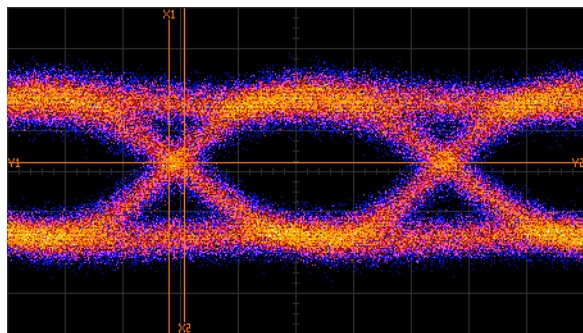

Unfiltered Eye Diagram for 2.125 Gbps @ -26.5 dBm

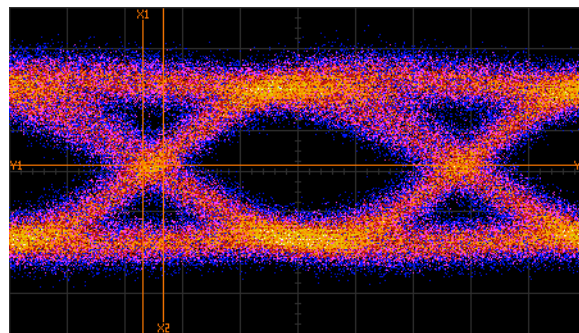

Unfiltered Eye Diagram for 2.5 Gbps @ -26 dBm

1.0 Product Specification

1.1 Absolute Maximum Ratings

These are the absolute maximum ratings at or beyond which the IC can be expected to fail or be damaged. Reliable operation at these extremes for any length of time is not implied.

Table 1-1. Absolute Maximum Ratings

Symbol	Parameter	Rating	Units
V_{CC}	Power supply ($V_{CC} - GND$)	-0.4 to +4.0	V
T_{STG}	Storage temperature	-65 to +150	°C
I_{IN}	PINA Input current	8.0 ^(1,2)	mA _{PP}
V_{PINA}, V_{AGC}	Maximum input voltage at PINA and AGC	-0.4 to +2.0 ⁽²⁾	V
I_{PINK}	Maximum average current sourced out of PINK	10.0	mA
V_{PINK}, V_{MON}	Maximum input voltage at PINK and MON	-0.4 to $V_{CC} + 0.4$	V
I_{Dout}	Maximum average current sourced out of Dout and DoutB	10.0 ⁽³⁾	mA
V_{Dout}	Maximum input voltage at Dout and DoutB	0.0 to +2.0 ⁽³⁾	V

NOTES:

- Equivalent to 4.9 mA average current.
- Do not exceed either the I_{IN} or V_{PINA} rating. PINA damage will result in performance degradation which is difficult to detect.
- Do not exceed either the I_{Dout} or V_{Dout} rating. Output device damage could occur.

1.2 Recommended Operating Conditions

Table 1-2. Recommended Operating Conditions

Symbol	Parameter	Rating	Units
V_{CC}	Power supply ($V_{CC} - GND$)	$3.3 \pm 10\%$	V
C_{PD}	Max. Photodiode capacitance ($V_r = 1.8V$), for 2.125 Gbps and 2.5 Gbps data rate	0.5	pF
T_A	Operating ambient temperature	-40 to +95	°C

1.3 DC Characteristics

Table 1-3. DC Characteristics

Symbol	Parameter	Min.	Typ.	Max.	Units
V_B	Photodiode bias voltage (PINK - PINA)	1.7	2.0	2.2	V
V_{CM}	Common mode output voltage	0.7	1	1.3	V
I_{CC}	Supply current (no loads)	24	32	40	mA
R_{LOAD}	Recommended differential output loading	85	100 ⁽¹⁾	–	Ω

NOTES:

1. 100 Ω is the load presented by the limiting amplifier.

Low Power CMOS Transimpedance Amplifier with Rx Pwr Mon Output and AGC for Fiber Optic Networks up to 2.5 Gbps

Rev V6

1.4 AC Characteristics

Table 1-4. AC Characteristics

Symbol	Parameter	Condition	Min.	Typ. ⁽¹⁾	Max.	Units
R _{OUT}	Output impedance (single ended)	–	30	50	70	Ω
LFC	Low frequency cutoff ⁽³⁾	–	–	35	50	kHz
V _D	Differential output voltage	100Ω differential load	–	250	425	mV
DCD	Duty Cycle Distortion	2.125 Gbps	–	–	50	ps
		2.5 Gbps	–	–	60	
DJ	Deterministic Jitter (includes DCD)	2.125 Gbps, 2 ⁷ - 1 PRBS	–	–	60	pspp
		2.5 Gbps, 2 ²³ - 1 PRBS	–	–	70	
PDJ	Pattern Dependant Jitter (at crossing point) with no DCD	2.125 Gbps, 2 ⁷ - 1 PRBS	–	–	29	pspp
		2.5 Gbps, 2 ²³ - 1 PRBS	–	–	34	
I _{n_rms}	Total input RMS noise	DC to 1.59 GHz (Bessel Filter), C _{in} = 0.5 pf	–	280	–	nA
		DC to 1.87 GHz (Bessel Filter), C _{in} = 0.5 pf	–	290	360	
PIN _{mean_min}	Minimum Input Optical Sensitivity ⁽²⁾	2.125 Gbps, BER < 10 ⁻¹⁰	–	-26.2	–	dBm
		2.125 Gbps, BER < 10 ⁻¹²	–	-25.7	–	
		2.5 Gbps, BER < 10 ⁻¹⁰	–	-26.0	–	
I _{mon_off}	Monitor Output Offset	–	–	–	8	μA
I _{mon_error}	Monitor Output Accuracy ⁽⁴⁾	V _{MON} = 0 to 2V	–	–	±1.75	dB

NOTES:

1. Die designed to operate over an ambient temperature range of -40°C to +95°C, T_A and V_{CC} range from 3.0 - 3.6V. Typical values are tested at T_A = 25° C and V_{CC} = 3.3V.
2. At stated data rate and BER. PD capacitance = 0.5 pF, Responsivity = 0.9 A/W, Extinction Ratio = 10, Temp = 25°C.
3. -26 dBm, Extinction Ratio = 10, Temp = 25°C.
4. After offset removed.

1.5 Dynamic Characteristics

Table 1-5. Dynamic Characteristics

Symbol	Parameter	Min.	Typ.	Max.	Units
G	Transimpedance				
	- Single ended	2.5	4.5	5.75	kΩ
	- Differential	5	9	11.5	
BW	Bandwidth to -3 dB point @ -26 dBm, 0.9 A/W, 0.5 pF PD	1400	1800	–	MHz
RC	AGC loop time constant	–	2	–	μs
I _{AGC}	AGC threshold	–	32	–	μA _{pp}
I _{OVL}	Input overload current	3.3 ⁽¹⁾	–	–	mA _{pp}
PSRR	Power supply rejection, f < 1 MHz	20	27	–	dB

NOTES:

1. To meet ac Specifications, equivalent to +3 dBm input optical power at Extinction Ratio = 10, Responsivity = 1.0 A/W.

1.6 Typical Performance

$V_{CC} = 3.3V$, Temperature = 25°C, $L_{IN} = 1\text{ nH}$, unless otherwise stated.

Figure 1-1. Typical Performance Diagrams 1 of 5

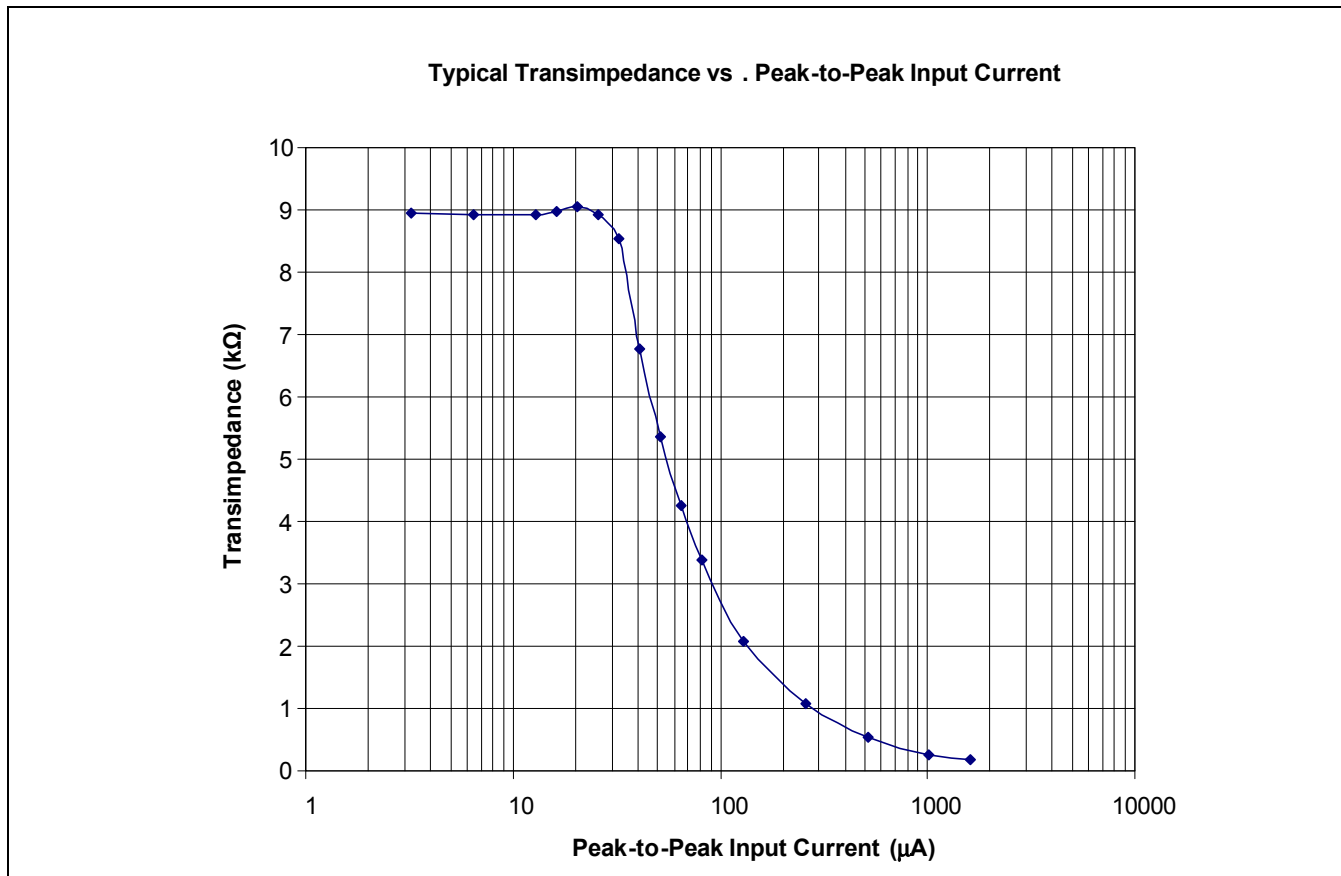

Low Power CMOS Transimpedance Amplifier with Rx Pwr Mon Output and AGC for Fiber Optic Networks up to 2.5 Gbps

Rev V6

$V_{CC} = 3.3V$, Temperature = 25°C, $L_{IN} = 1$ nH, unless otherwise stated.

Figure 1-2. Typical Performance Diagrams 2 of 5

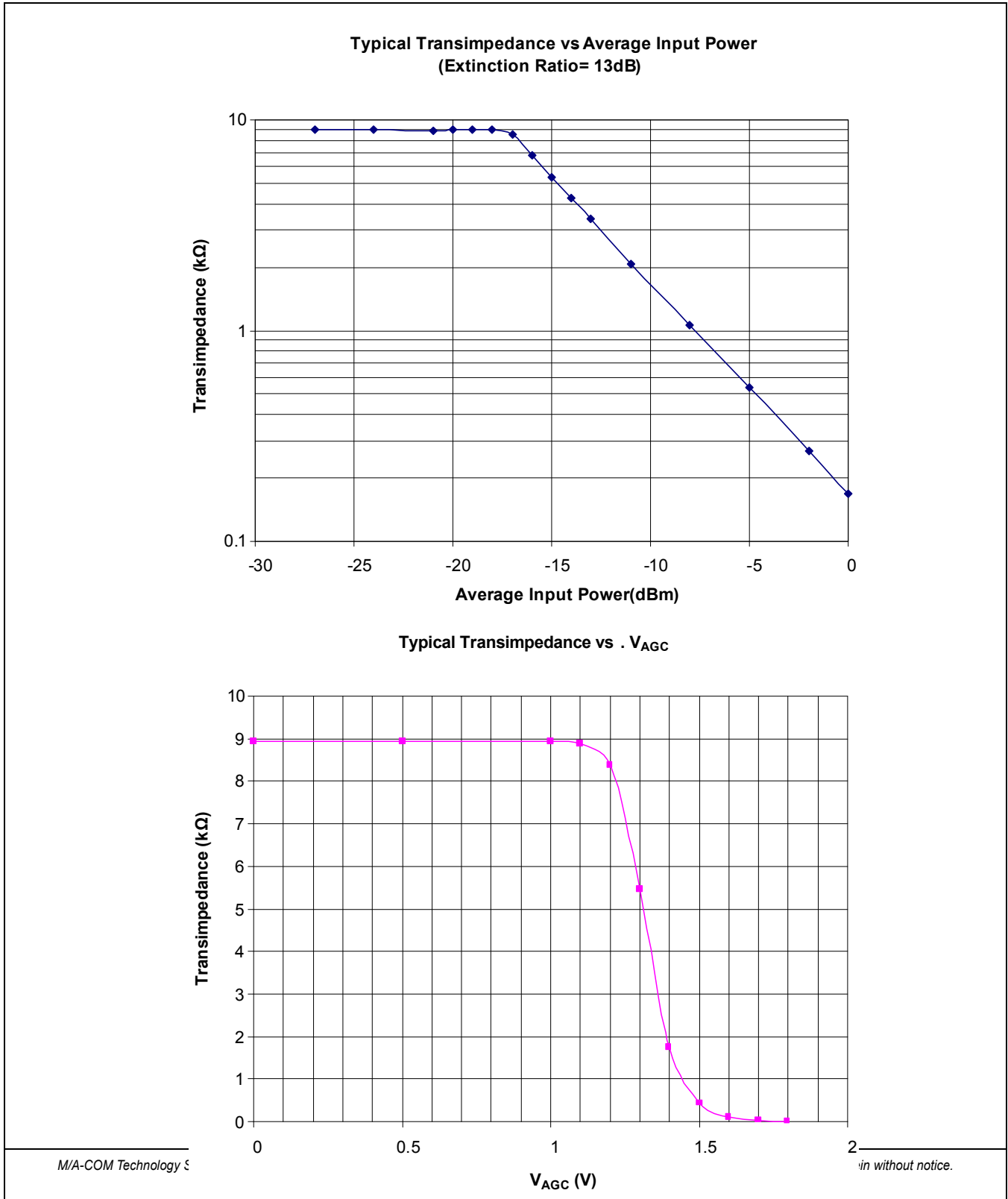

Low Power CMOS Transimpedance Amplifier with Rx Pwr Mon Output and AGC for Fiber Optic Networks up to 2.5 Gbps

Rev V6

$V_{CC} = 3.3V$, Temperature = 25°C, $L_{IN} = 1$ nH, unless otherwise stated.

Figure 1-3. Typical Performance Diagrams 3 of 5

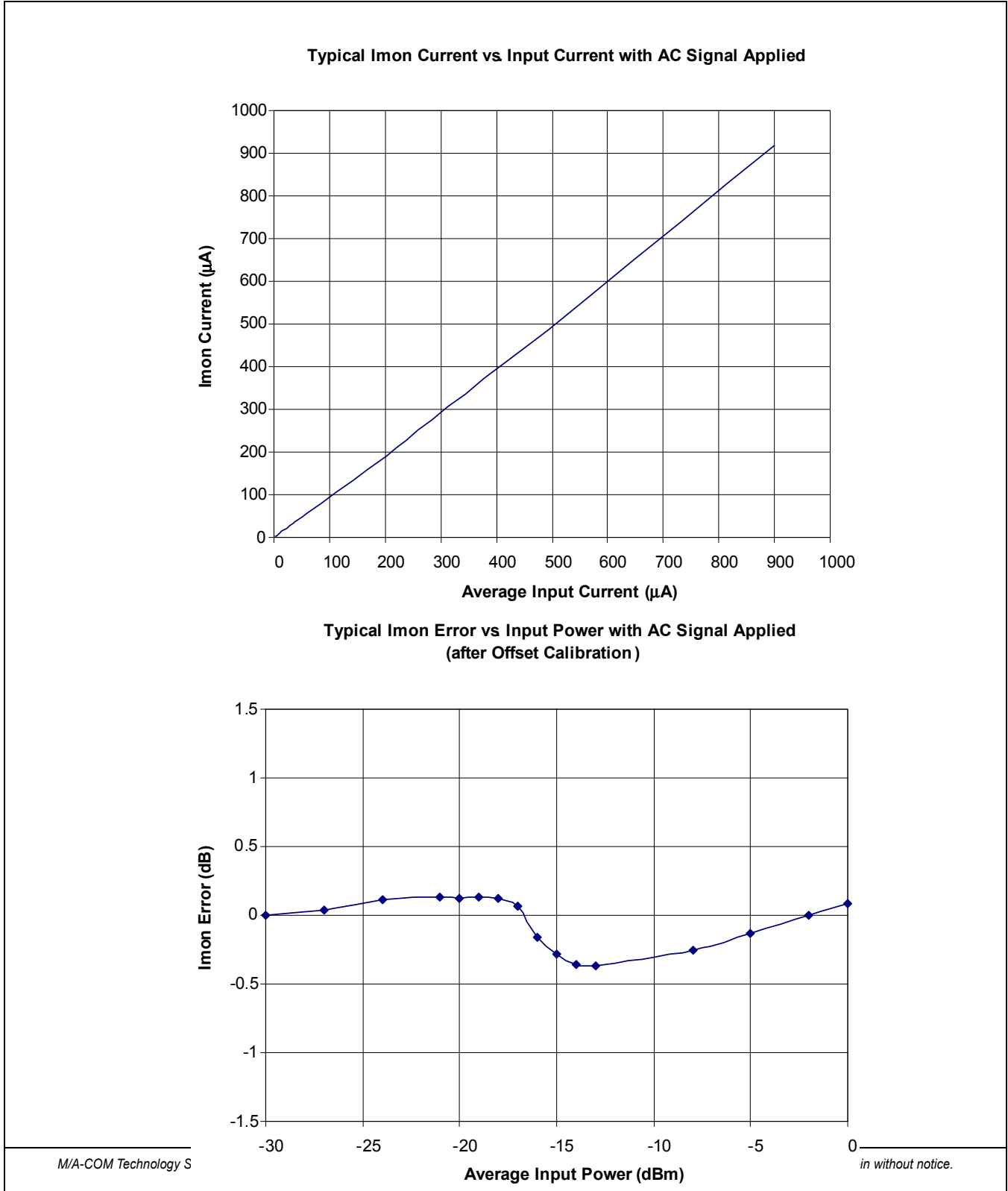

Low Power CMOS Transimpedance Amplifier with Rx Pwr Mon Output and AGC for Fiber Optic Networks up to 2.5 Gbps

Rev V6

$V_{CC} = 3.3V$, Temperature = 25°C, $L_{IN} = 1$ nH, unless otherwise stated.

Figure 1-4. Typical Performance Diagrams 4 of 5

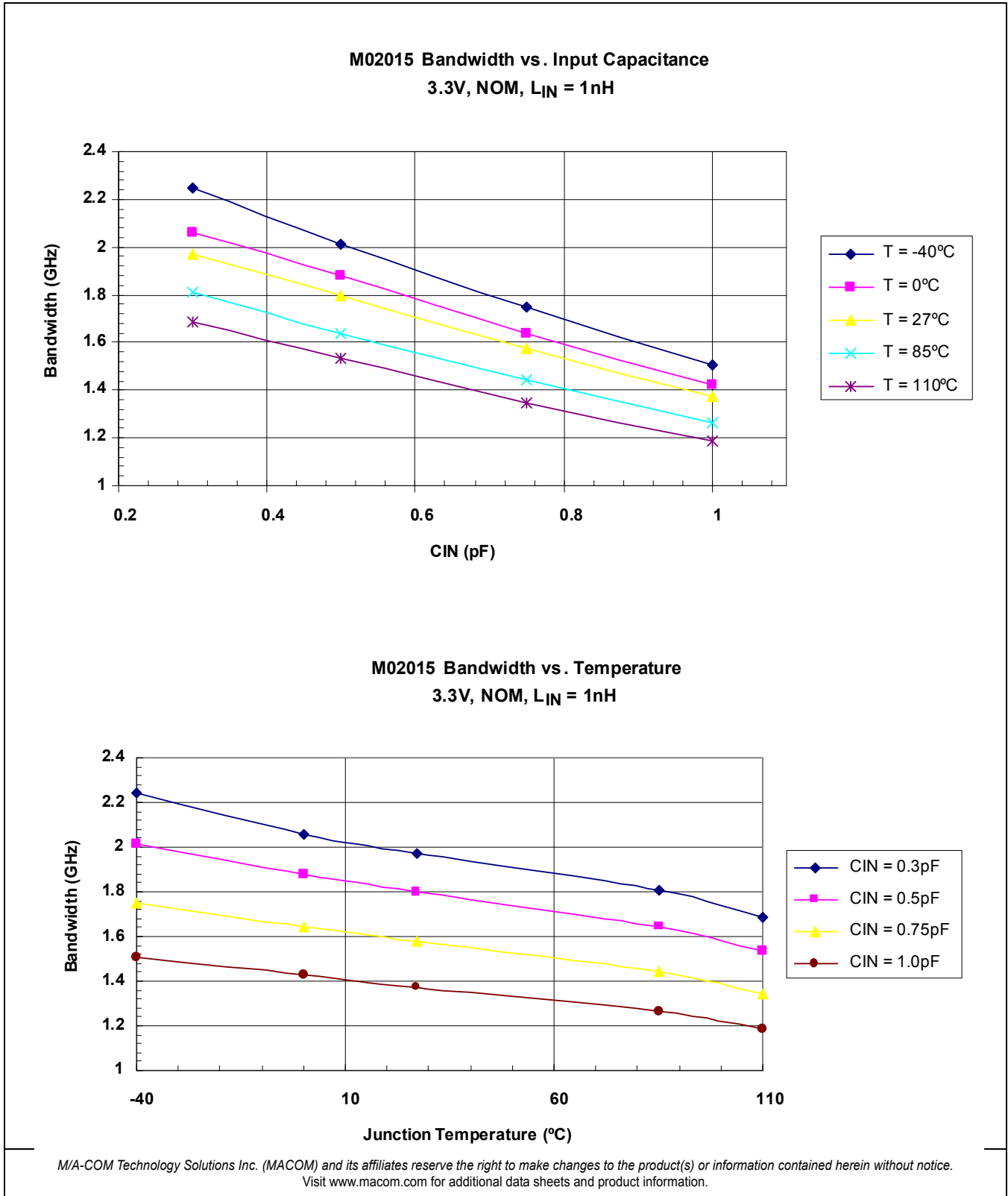

Low Power CMOS Transimpedance Amplifier with Rx Pwr Mon Output and AGC for Fiber Optic Networks up to 2.5 Gbps

Rev V6

$V_{CC} = 3.3V$, Temperature = 25°C, $L_{IN} = 1$ nH, unless otherwise stated.

Figure 1-5. Typical Performance Diagrams 5 of 5

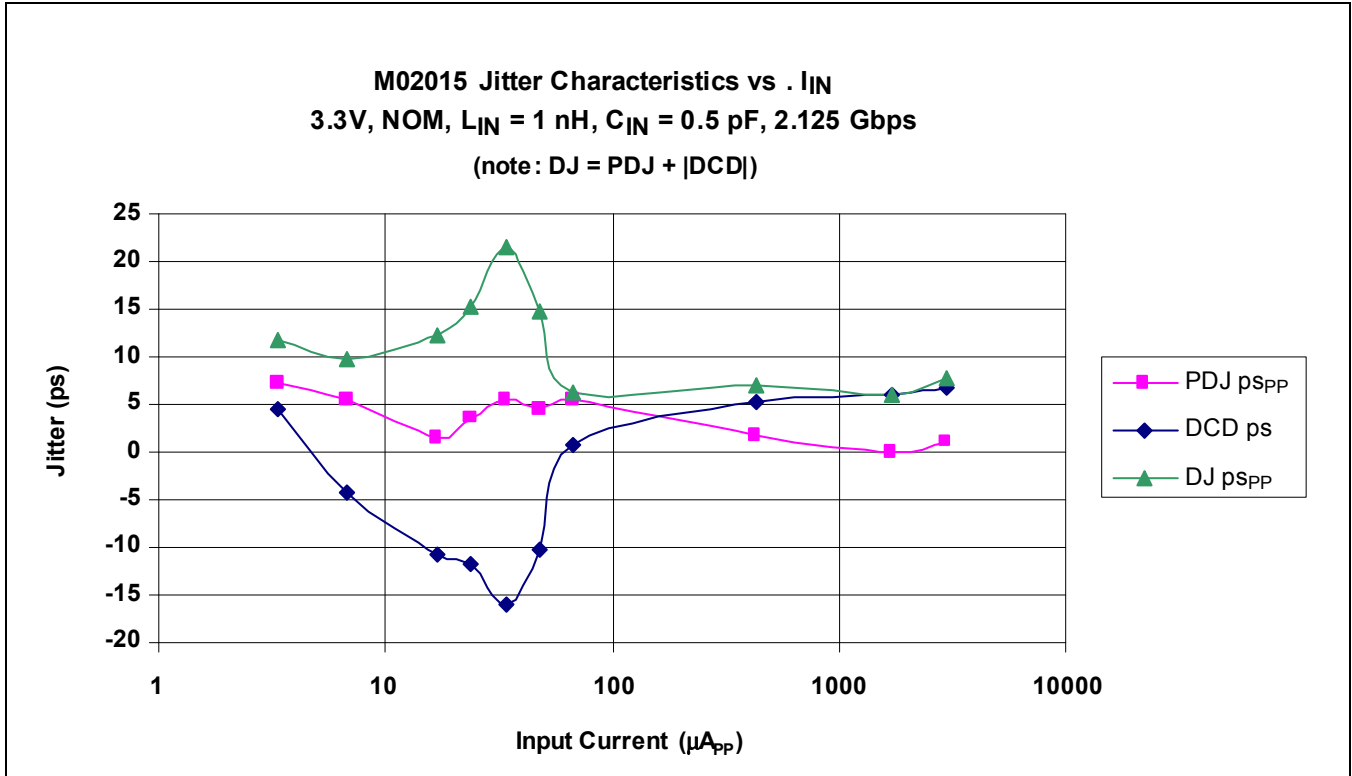

2.0 Pad Definitions

Table 2-1. Pad Description

Die Pad No	Name	Function
1	AGC	Monitor or force AGC voltage
2	V _{CC}	Power pin. Connect to most positive supply
3	PINK	Common PIN input. Connect to photo diode cathode and a 470 pF capacitor to Gnd ⁽¹⁾
4	PINA	Active PIN input. Connect to photo diode anode
5	V _{CC}	Power pin. Connect to most positive supply (only one V _{CC} pad needs to be connected)
6	MON	Analog current source output. Current matched to average photodiode current
7	DOUT	Differential data output (goes low as light increases)
8	$\overline{\text{DOUT}}\text{GND}$	Ground return for $\overline{\text{DOUT}}$ pad ⁽²⁾
9	GND	Ground pin. Connect to the most negative supply ⁽²⁾
10	GND	Ground pin. Connect to the most negative supply ⁽²⁾
11	DOUTGND	Ground return for DOUT pad ⁽²⁾
12	DOUT	Differential data output (goes high as light increases)
NA	Backside	Backside. Connect to the lowest potential, usually ground

NOTES:

- Alternatively the photodiode cathode may be connected to a decoupled positive supply, e.g. V_{CC}.
- All ground pads are common on the die. Only one ground pad needs to be connected to the TO-Can ground. However, connecting more than one ground pad to the TO-Can ground, particularly those across the die from each other can improve performance in noisy environments.

Low Power CMOS Transimpedance Amplifier with Rx Pwr Mon Output and AGC for Fiber Optic Networks up to 2.5 Gbps

Rev V6

Figure 2-1. Bare Die Layout

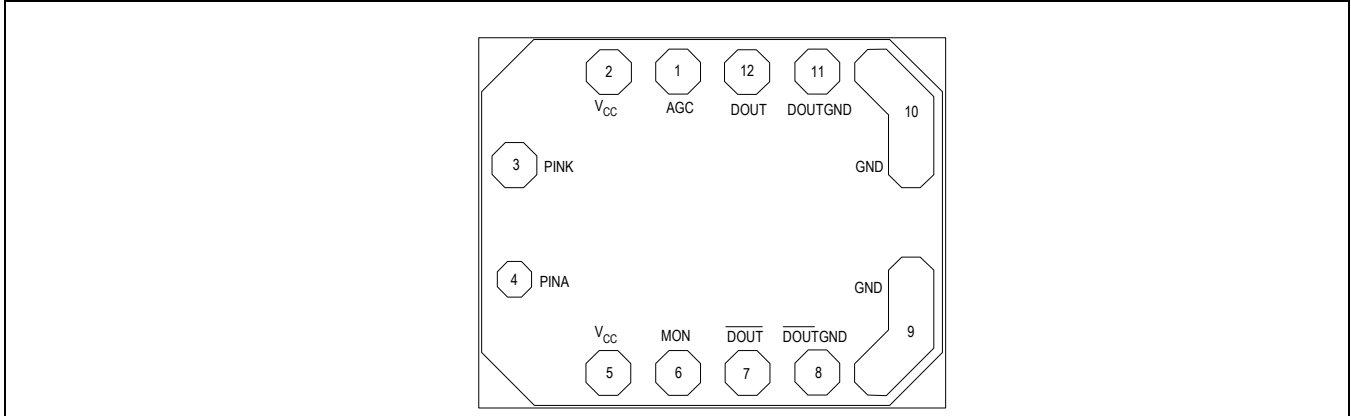

3.0 Functional Description

3.1 Overview

The M02015 is a CMOS transimpedance amplifier with AGC. The AGC gives a wide dynamic range of 32 dB. The high transimpedance gain of 9.0 k Ω ensures good sensitivity.

For optimum system performance, the M02015 die should be mounted with a GaAs or InGaAs PIN photodetector inside a lensed TO-Can or other optical sub-assembly.

The M02015 can either bias the PIN diode from the internal regulator or use an externally biased PIN diode.

A replica of the average photodiode current is available at the MON pad for photo-alignment and Receive Power monitoring (SFF-8472 compliant).

Figure 3-1. M02015 Block Diagram

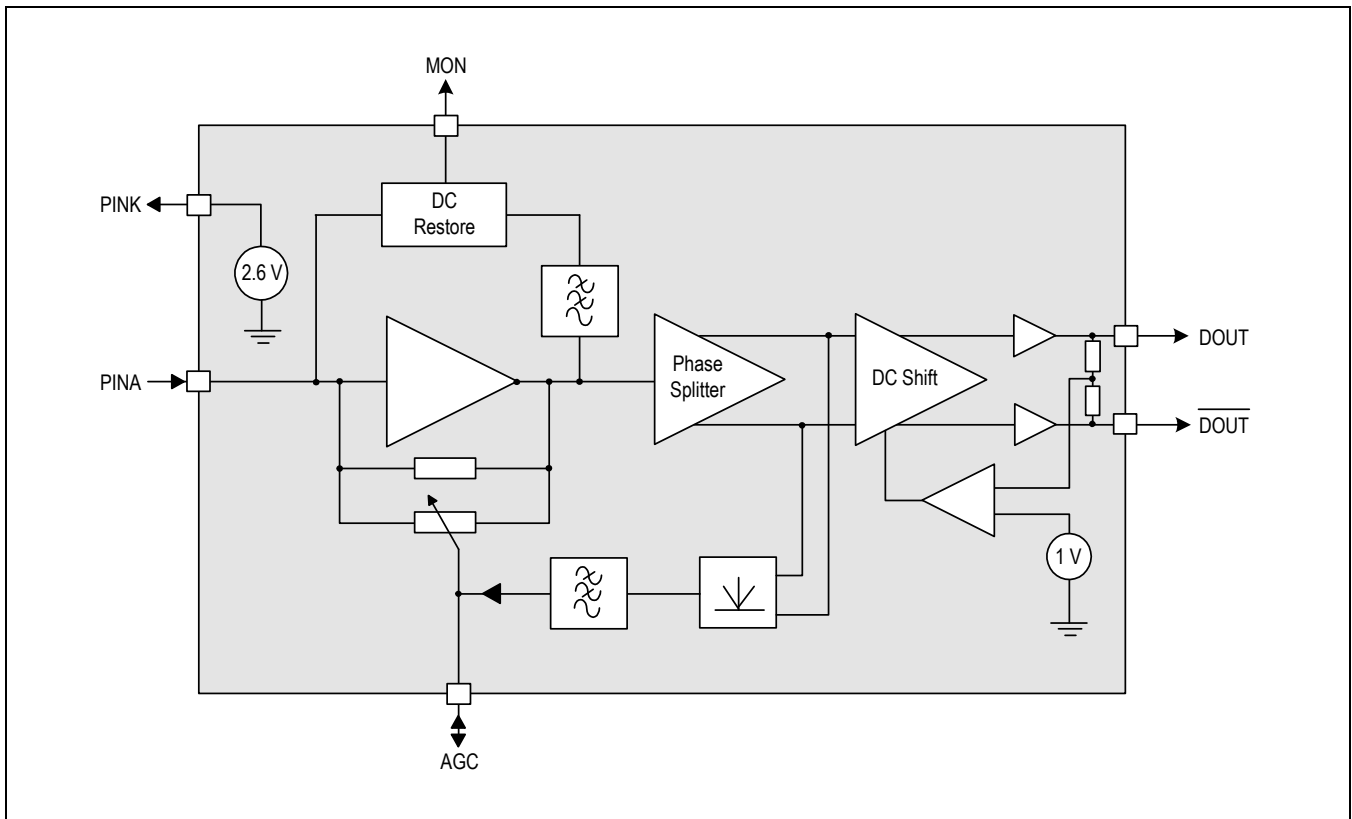

3.2 General Description

3.2.1 TIA (Transimpedance Amplifier)

The transimpedance amplifier consists of a high gain single-ended CMOS amplifier (TIA) with a feedback resistor. The feedback creates a virtual ground low impedance at the input and virtually all of the input current passes through the feedback resistor defining the voltage at the output. Advanced CMOS design techniques are employed to maintain the stability of this stage across all input conditions.

An on-chip low dropout linear regulator has been incorporated into the design to give excellent noise rejection up to several MHz. Higher frequency power supply noise is removed by the external 470 pF decoupling capacitor connected to PINK.

The circuit is designed for PIN photodiodes in the “grounded cathode” configuration, with the anode connected to the input of the TIA and the cathode connected to AC ground, such as the provided PINK terminal. Reverse DC bias is applied to reduce the photodiode capacitance. Avalanche photodiodes can be connected externally to a higher voltage.

3.2.2 AGC

The M02015 has been designed to operate over the input range of +6 dBm to -26 dBm. This represents a ratio of 1:1500 whereas the acceptable dynamic range of the output is only 1:30 which implies a compression of 50:1 in the transimpedance. The design uses a MOS transistor operating in the triode region as a “voltage controlled resistor” to achieve the transimpedance variation.

Another feature of the AGC is that it only operates on signals greater than -17 dBm (@0.9 A/W). This knee in the gain response is important when setting “signal detect” functions in the following post amplifier. It also aids in active photodiode alignment.

The AGC pad allows the AGC to be disabled during photodiode alignment by grounding the pad through a low impedance. The AGC control voltage can be monitored during normal operation at this pad by a high impedance (>10 M Ω) circuit.

3.2.3 Output Stage

The signal from the TIA enters a phase splitter followed by a DC-shift stage and a pair of voltage follower outputs. These are designed to drive a differential (100 Ω) load. They are stable for driving capacitive loads such as interstage filters. Each output has its own GND pad; all four GND pads on the chip should be connected for proper operation. Since the M02015 exhibits rapid roll-off (3 pole), simple external filtering is sufficient.

3.2.4 Monitor O/P

High impedance output sources a replica average photodiode current for monitoring purposes. This output is compatible with the DDMI Receive Power Specification (SFP-8472) and MACOM's range of DDMI controllers. Ensure that the voltage on V_{MON} is in the range of 0 to 2V. Refer to [Figure 4-1](#).

4.0 Applications Information

4.1 Recommended Pin Diode Connections

Figure 4-1. Suggested PIN Diode Connection Methods

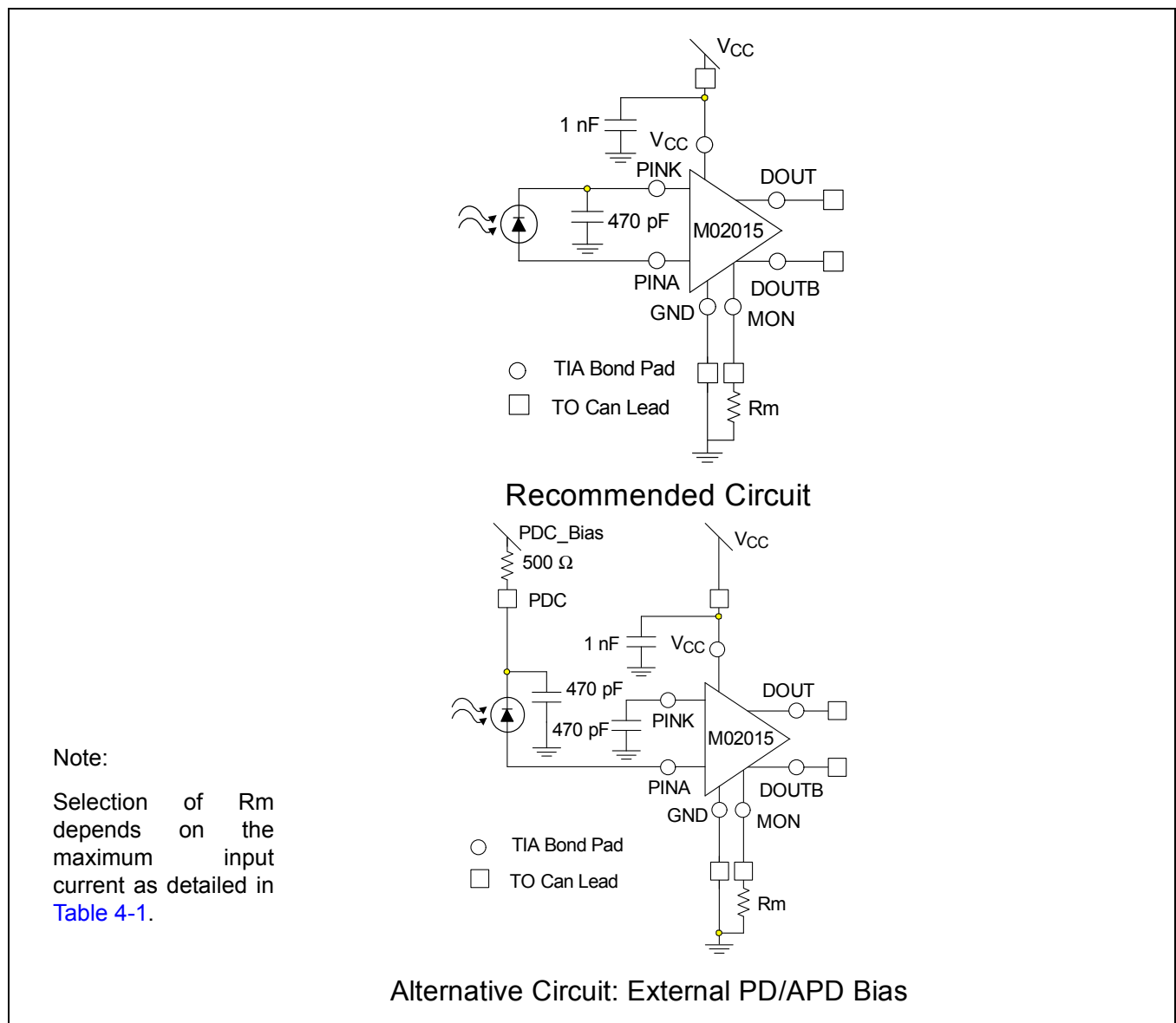

4.2 Selecting the Monitor Resistor

As described earlier the high impedance monitor output sources a replica average photodiode current for monitoring purposes. If detected by converting the current to a voltage through an external resistor (Figure 4-1), ensure that the voltage on V_{MON} is in the range of 0 to 2V. The table below provides suggested values for the monitor resistor.

Table 4-1. Selection of R_m for Maximum Input Current

I_{IN} Max (mA)	Optical Power (dBm)	R_m (Ω)
4	+6	500
2	+3	1000
1	0	2000
0.5	-3	4000

4.3 TO-Can Layout

Figure 4-2. Typical Layout Diagram with Photodiode Mounted on PINK Capacitor (5 pin TO-Can)

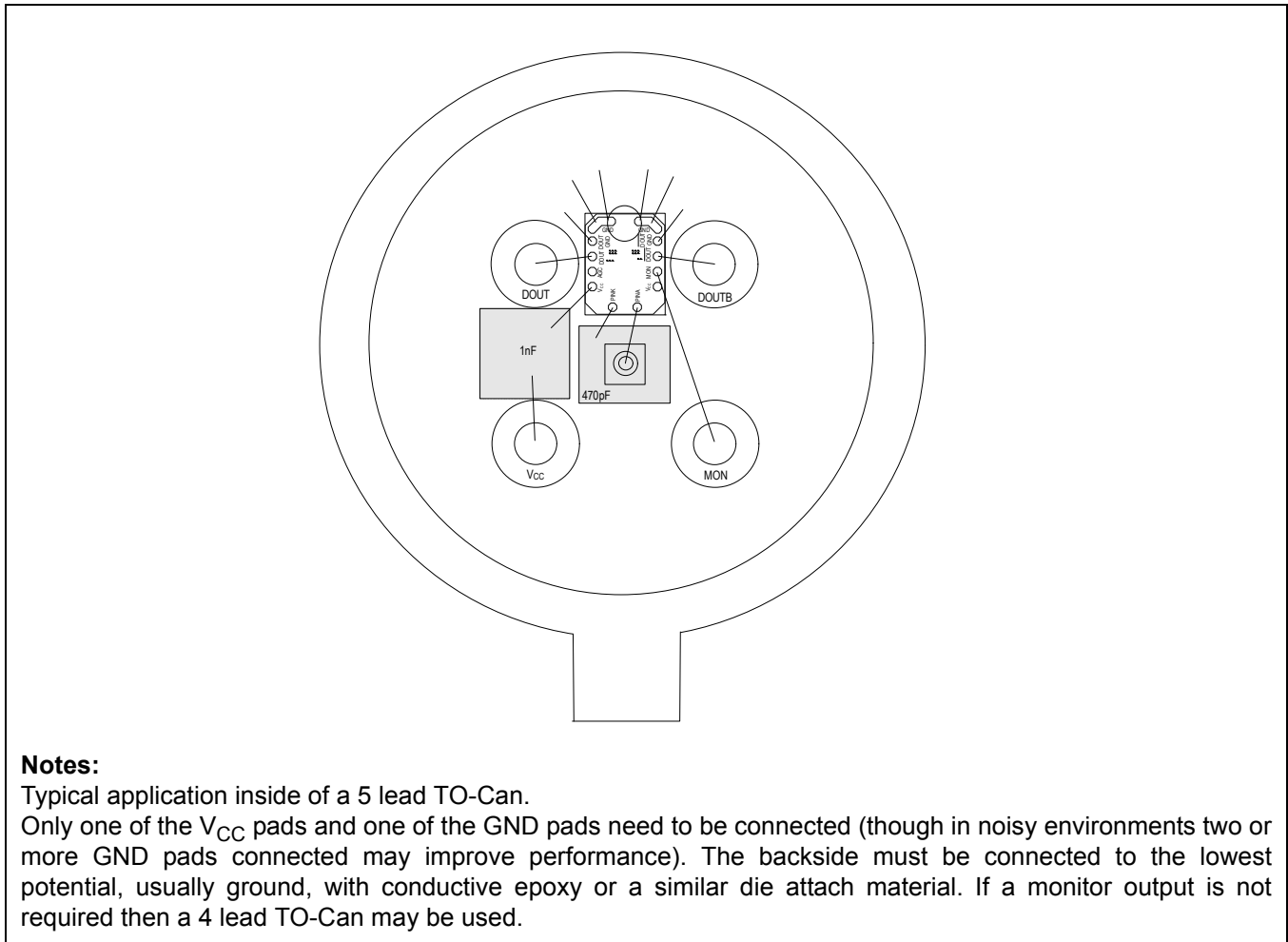
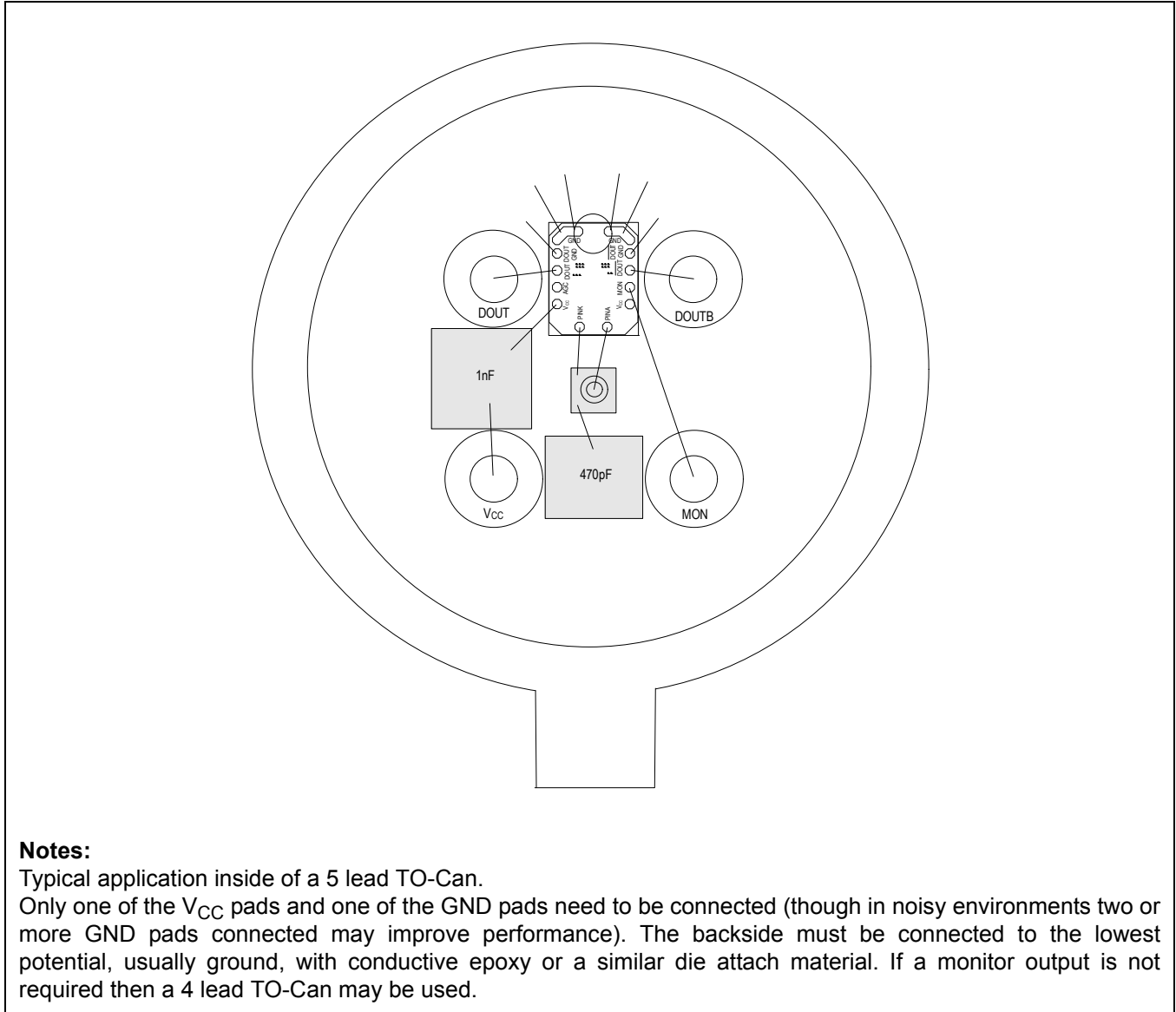

Figure 4-3. Typical Layout Diagram with Photodiode Mounted on TO-Can base (5 pin TO-Can)



4.4 Treatment of PINK

PINK requires bypassing to ground with a 470 pF capacitor when powering a photo diode. If PINK is not used to bias the photo diode, then it is not necessary to bypass an unused PINK.

4.5 T0-Can Assembly Recommendations

Figure 4-4. T0-Can Assembly Diagram

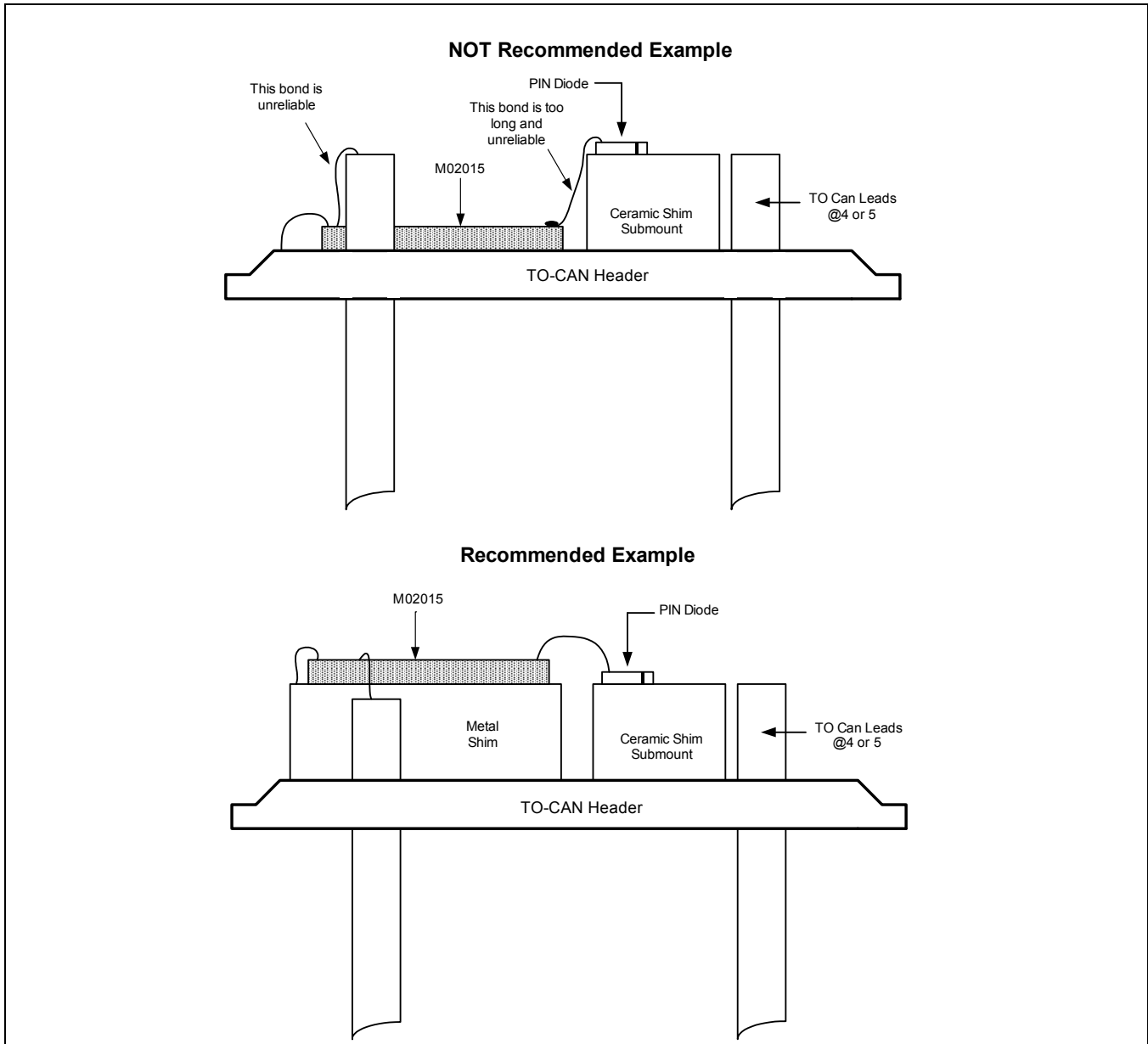

4.5.1 Assembly

The M02015 is designed to work with a wirebond inductance of $1 \text{ nH} \pm 0.25 \text{ nH}$. Many existing TO-Can configurations will not allow wirebond lengths that short, since the PIN diode submount and the TIA die are more

Low Power CMOS Transimpedance Amplifier with Rx Pwr Mon Output and AGC for Fiber Optic Networks up to 2.5 Gbps

Rev V6

than 1 mm away in the vertical direction, due to the need to have the PIN diode in the correct focal plane. This can be remedied by raising up the TIA die with a conductive metal shim. This will effectively reduce the bond wire length. Refer to [Figure 4-4](#) above for details.

MACOM recommends ball bonding with a 1 mil (25.4 μm) gold wire. For performance reasons the PINA pad is smaller than the others and also has less via material connected to it. It therefore requires more care in setting of the bonding parameters. **For the same reason PINA has no ESD protection.**

In addition, please refer to the MACOM Product Bulletin (document number 0201X-PBD-002). Care must be taken when selecting chip capacitors, since they must have good low ESR characteristics up to 1.0 GHz. It is also important that the termination materials of the capacitor be compatible with the attach method used.

For example, Tin/Lead (Pb/Sn) solder finish capacitors are incompatible with silver-filled epoxies. Palladium/Silver (Pd/Ag) terminations are compatible with silver filled epoxies. Solder can be used only if the substrate thick-film inks are compatible with Pb/Sn solders.

4.5.2 Recommended Assembly Procedures

For ESD protection the following steps are recommended for TO-Can assembly:

- a. Ensure good humidity control in the environment (to help minimize ESD).
- b. Consider using additional ionization of the air (also helps minimize ESD).
- c. As a minimum, it is best to ensure that the body of the TO-can header or the ground lead of the header is grounded through the wire-bonding fixture for the following steps. The best solution also ensures that the V_{CC} lead of the TO-Can is also grounded. When this is done and the procedure below is followed, any positive charge on the wire bonder when bonding to PINA (the very last bond placed) will have the PD acting as an ESD diode into PinK of the device. Internally, PinK has an ESD diode between it and VCC that will turn on if V_{CC} is at ground minimizing the ESD event at PINA.
- d. The wire bonder (including the spool, clamp, etc.) must also be grounded.
 1. Wire-bond the ground pad(s) of the die first.
 2. Then wire bond the V_{CC} pad to the TO-Can lead.
 3. Then wire bond any other pads going to the TO-Can leads (such as DOUT, DOUT and possibly MON).
 4. Next wire-bond any capacitors inside the TO-Can.
 5. Inside the TO-Can, wire bond PINK.
 6. The final step is to wire bond PINA.

4.6 TIA Use with Externally Biased Detectors

In some applications, MACOM TIAs are used with detectors biased at a voltage greater than available from TIA PIN cathode supply. This works well if some basic cautions are observed. When turned off, the input to the TIA exhibits the following I/V characteristic:

Figure 4-5. TIA Use with Externally Biased Detectors, Powered Off

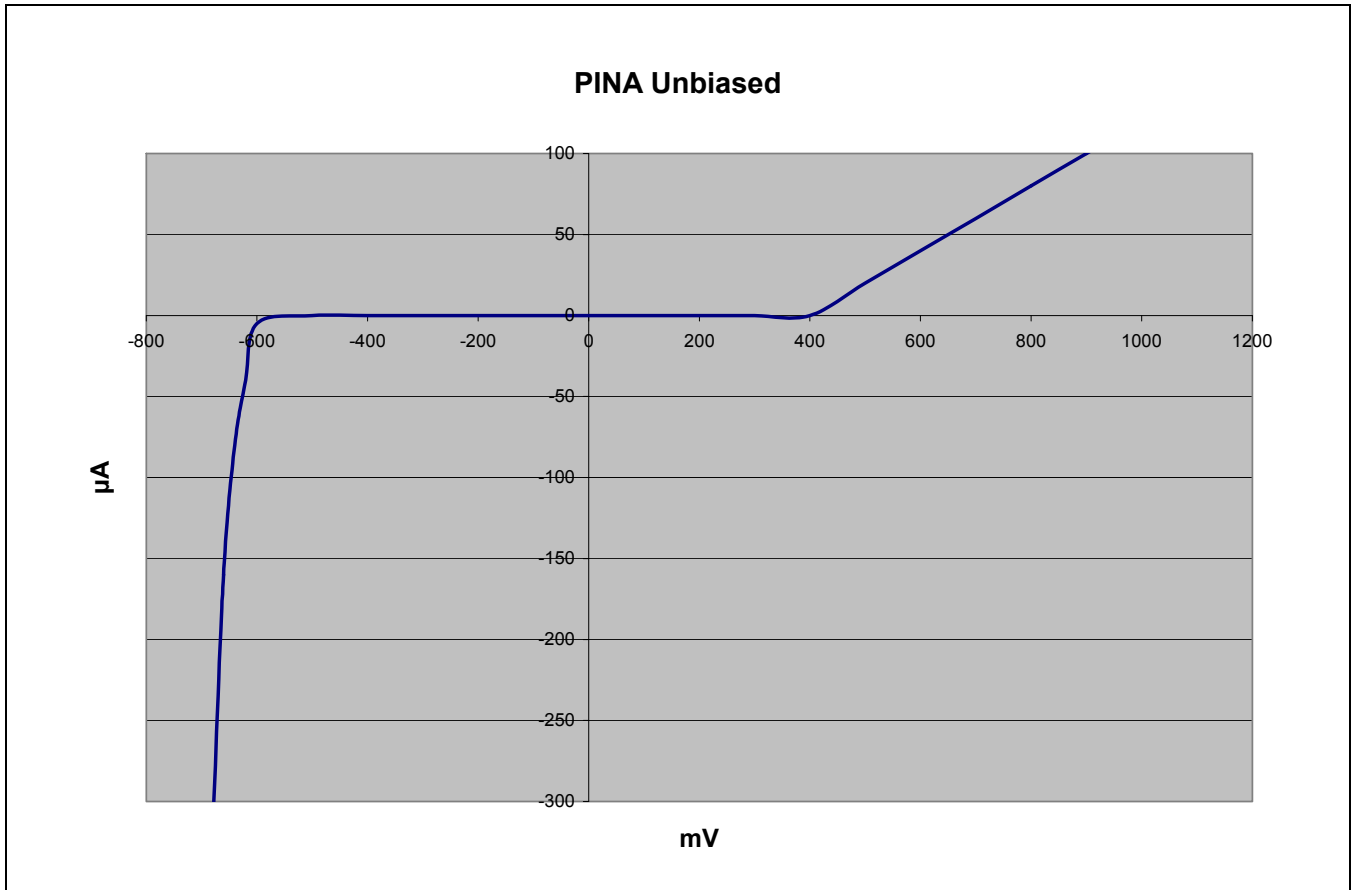

In the positive direction the impedance of the input is relatively high.

Low Power CMOS Transimpedance Amplifier with Rx Pwr Mon Output and AGC for Fiber Optic Networks up to 2.5 Gbps

Rev V6

After the TIA is turned on, the DC servo and AGC circuits attempt to null any input currents (up to the absolute maximum stated in [Table 1-1](#)) as shown by the I/V curve in [Figure 4-6](#).

Figure 4-6. TIA Use with Externally Biased Detectors, Powered On

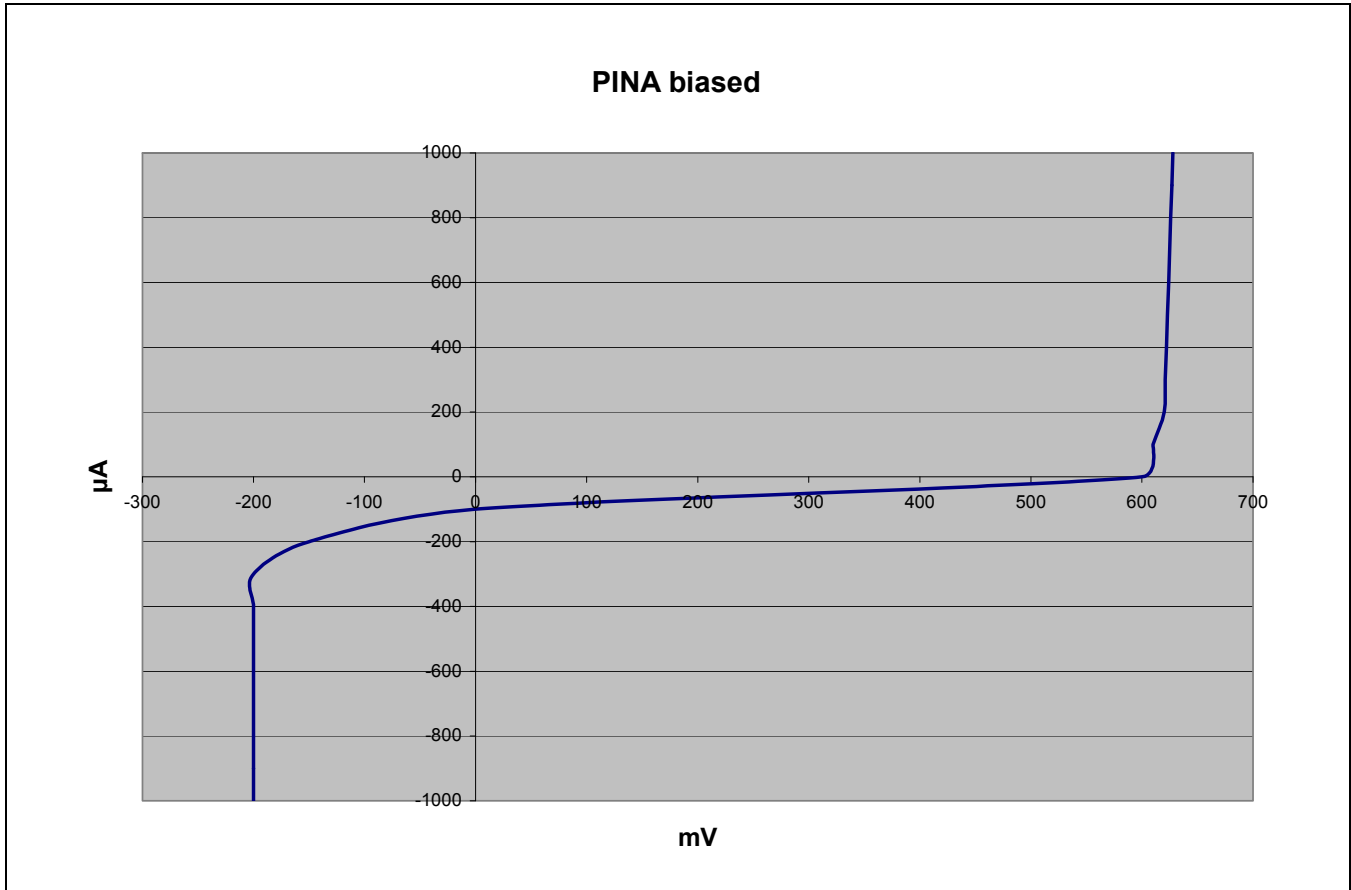

It can be seen that any negative voltage below 200 mV is nulled and that any positive going voltage above the PINA standing voltage is nulled by the DC servo. The DC servo upper bandwidth varies from part to part, but is generally at least 30 kHz.

When externally biasing a detector such as an APD where the supply voltage of the APD exceeds that for PINA [Table 1-1](#), care should be taken to power up the TIA first and to keep the TIA powered up until after the power supply voltage of the APD is removed. Failure to do this with the TIA unpowered may result in damage to the input FET gate at PINA. In some cases the damage may be very subtle, in that nearly normal operation may be experienced with the damage causing slight reductions in bandwidth and corresponding reductions in input sensitivity.

5.0 Die Specification

Figure 5-1. Bare Die Layout

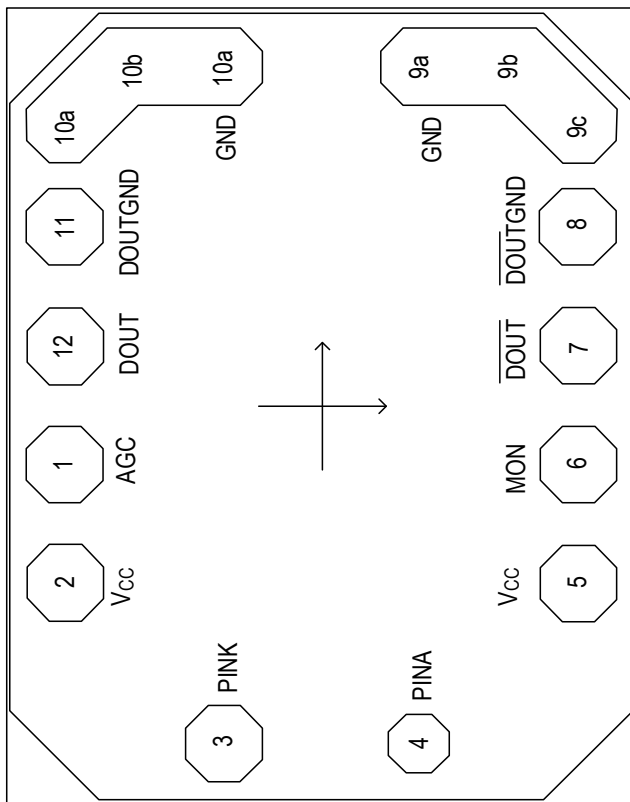

Pad Number	Pad	X	Y
1	AGC	-329	-76
2 (1)	V _{CC}	-329	-228
3	PINK	-124	-434
4	PINA	124	-434
5 (1)	V _{CC}	329	-228
6	MON	329	-76
7	DOUT	329	76
8 (1)	DOUTGND	329	228
9c (1, 2)	GND	329	360
9b (1, 2)	GND	255	434
9a (1, 2)	GND	124	434
10a (1, 2)	GND	-124	434
10b (1, 2)	GND	-255	434
10c (1, 2)	GND	-329	360
11 (1)	DOUTGND	-329	228
12	DOUT	-329	76

Notes:

Process technology: CMOS, Silicon Nitride passivation
 Die thickness: 300 μm
 Pad metallization: Aluminium
 Die size: 880 μm x 1090
 Pad opening (except PinA): 86 μm across flat sides
 PinA pad: 70 μm across flat sides (70 μm x 70 μm)
 Pad Centers in μm referenced to center of device
 Connect backside bias to ground

NOTES:

- It is only necessary to bond one V_{CC} pad and one GND pad. However, bonding one of each pad (if available) on each side of the die is encouraged for improved performance in noisy environments.
- Each location is an acceptable bonding location.

Low Power CMOS Transimpedance Amplifier with Rx Pwr Mon Output and AGC for Fiber Optic Networks up to 2.5 Gbps

Rev V6

M/A-COM Technology Solutions Inc. All rights reserved.

Information in this document is provided in connection with M/A-COM Technology Solutions Inc ("MACOM") products. These materials are provided by MACOM as a service to its customers and may be used for informational purposes only. Except as provided in MACOM's Terms and Conditions of Sale for such products or in any separate agreement related to this document, MACOM assumes no liability whatsoever. MACOM assumes no responsibility for errors or omissions in these materials. MACOM may make changes to specifications and product descriptions at any time, without notice. MACOM makes no commitment to update the information and shall have no responsibility whatsoever for conflicts or incompatibilities arising from future changes to its specifications and product descriptions. No license, express or implied, by estoppel or otherwise, to any intellectual property rights is granted by this document.

THESE MATERIALS ARE PROVIDED "AS IS" WITHOUT WARRANTY OF ANY KIND, EITHER EXPRESS OR IMPLIED, RELATING TO SALE AND/OR USE OF MACOM PRODUCTS INCLUDING LIABILITY OR WARRANTIES RELATING TO FITNESS FOR A PARTICULAR PURPOSE, CONSEQUENTIAL OR INCIDENTAL DAMAGES, MERCHANTABILITY, OR INFRINGEMENT OF ANY PATENT, COPYRIGHT OR OTHER INTELLECTUAL PROPERTY RIGHT. MACOM FURTHER DOES NOT WARRANT THE ACCURACY OR COMPLETENESS OF THE INFORMATION, TEXT, GRAPHICS OR OTHER ITEMS CONTAINED WITHIN THESE MATERIALS. MACOM SHALL NOT BE LIABLE FOR ANY SPECIAL, INDIRECT, INCIDENTAL, OR CONSEQUENTIAL DAMAGES, INCLUDING WITHOUT LIMITATION, LOST REVENUES OR LOST PROFITS, WHICH MAY RESULT FROM THE USE OF THESE MATERIALS.

MACOM products are not intended for use in medical, lifesaving or life sustaining applications. MACOM customers using or selling MACOM products for use in such applications do so at their own risk and agree to fully indemnify MACOM for any damages resulting from such improper use or sale.