

### Features

- Surface Mount Limiter in 8 mm x 5 mm x 2.5 mm Package
- Incorporates PIN Limiter & Schottky Diodes
- DC Blocks & DC Return
- Higher Average Power Handling than Plastic: 50 W CW Power
- Lower Insertion Loss: 0.8 dB
- Lower Flat Leakage Power: 17 dB
- RoHS\* Compliant

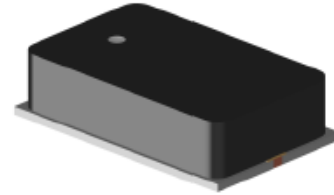

### Description

The LM102202-H-C-301 surface mount silicon PIN diode limiter is manufactured using proven hybrid manufacturing process incorporating PIN diodes and passive devices integrated within a ceramic substrate. This low profile, compact, surface mount component, (8 mm L x 5 mm W x 2.5 mm H) offers superior low and high signal performance to comparable MMIC devices in QFN packages. The limiter modules are designed to optimize small signal insertion loss, noise figure and high signal flat leakage performance in a compact, surface mount package. Using PIN diodes with lower thermal resistance (<math><10^{\circ}\text{C}/\text{W}</math>), and a De-coupled Schottky detector network as a current source, RF CW incident power levels of 47 dBm and RF peak incident power levels of 53 dBm @ 20  $\mu\text{s}$  RF pulse width, 1% duty cycle are very achievable. In addition, this design concept provides lower flat leakage power (<math><17\text{ dBm}</math>) and lower spike leakage energy (<math><0.5\text{ Ergs}</math>) for superior LNA protection.

This LM102202-H-C-301 limiter is ideal for octave band radar applications, requiring high volume, surface mount, solder re-flow manufacturing. These products are durable, reliable, and capable of meeting all military, commercial, and industrial environments. These devices are RoHS compliant and are available in tube or tape-reel.

### Limiter Schematic

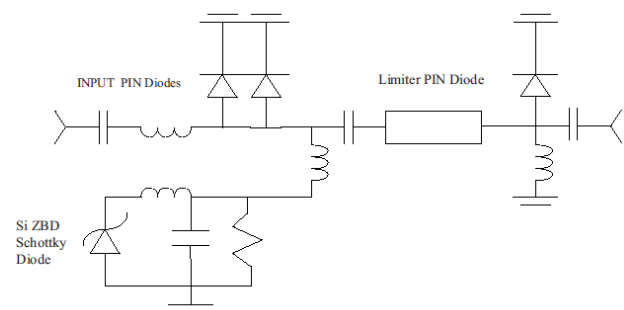

### Ordering Information

Part Number	Package
LM102202-H-C-301-T	tube packaging
LM102202-H-C-301-R	250 or 500 piece reel
LM102202-H-C-301-W	waffle packaging
LM102202-H-C-301-E	RF evaluation board with heat sink

\* Restrictions on Hazardous Substances, European Union Directive 2011/65/EU.

### Electrical Specifications: Freq.: 0.8 - 2.5 GHz, $T_A = +25^\circ\text{C}$ , $Z_0 = 50 \Omega$

Parameter	Test Conditions	Units	Min.	Typ.	Max.
Insertion Loss	Swept Frequency, $P_{OUT} = 0 \text{ dBm}$	dB	—	-0.7	-0.9
Return Loss	Swept Frequency, $P_{OUT} = 0 \text{ dBm}$	dB	-15	-16	—
Input Compression Power	Swept Frequency	dBm	7	8	10
2nd Harmonic	Output Frequency = 1 GHz, $P_{OUT} = 0 \text{ dBm}$	dBc	45	50	—
Peak Incident Power	Swept Frequency, RF Pulse Width = 20 $\mu\text{s}$ , 1% Duty	dBm	—	53	54
CW Incident Power	Swept Frequency	dBm	—	47	48
Flat Leakage Power	53 dBm, RF Pulse Width = 20 $\mu\text{s}$ , 1% Duty	dBm	—	17	18
Spike Leakage Power	53 dBm, RF Pulse Width = 20 $\mu\text{s}$ , 1% Duty	Ergs	—	0.3	0.5
Recovery Time	50% Trailing RF, Pulse - 1 dB IL, 53 dBm, RF Pulse Width = 20 $\mu\text{s}$ , 1% Duty	$\mu\text{s}$	—	3	5

### Absolute Maximum Ratings<sup>1,2</sup>

Parameter	Absolute Maximum
RF CW Incident Power @ $+85^\circ\text{C}$ , Source & Load VSWR <1.2:1	47 dBm
RF Peak Incident Power @ $+85^\circ\text{C}$ , Source & Load VSWR <1.2:1	53 dBm
Insertion Loss Rate of Change with Operating Temperature	-0.0025 dB / $^\circ\text{C}$
Assembly Temperature	260 $^\circ\text{C}$ for 10 seconds
Operating Temperature	+175 $^\circ\text{C}$
Operating Temperature	-65 $^\circ\text{C}$ to +125 $^\circ\text{C}$
Storage Temperature	-65 $^\circ\text{C}$ to +150 $^\circ\text{C}$

- Exceeding any one or combination of these limits may cause permanent damage to this device.
- MACOM does not recommend sustained operation near these survivability limits.

## Handling Procedures

Please observe the following precautions to avoid damage:

## Static and Moisture Sensitivity

These electronic devices are sensitive to electrostatic discharge (ESD) and can be damaged by static electricity. Proper ESD control techniques should be used when handling these Class 0 (HBM) devices.

The moisture sensitivity level rating for this device is MSL 1.

## Environmental Capabilities

This limiter is capable of meeting the environmental requirements of MIL-STD-750 and MIL-STD-202.

## Thermal Grounding Caution

Product engineering dictates that the LM family of high power limiters require proper heat sinking for high power applications >40 dBm (10 W). MACOM recommends using the part number PNMN13881 heat sink block which was developed for LM family.

## Assembly Instructions

The LM102202-H-C-301 limiters are capable of being placed onto circuit boards with pick and place manufacturing equipment from tube or tape & reel dispensing. The devices are attached to the circuit board using conventional solder re-flow or wave soldering procedures with RoHS type or Sn 60 / Pb 40 type solders per Table I & Graph I Time-Temperature recommended profile.

## RF Circuit Solder Footprint, case style 301 (CS301)

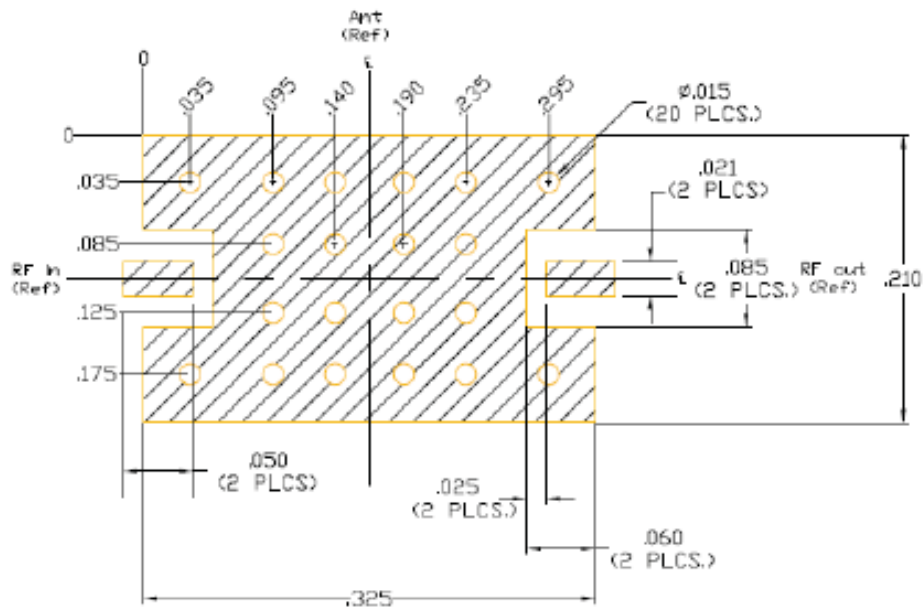

Recommended RF circuit is Rogers R04350B, 10 mils thick.

**Table 1: Time-Temperature Profile for Sn 60 / Pb 40 or RoHS Type Solders**

Profile Feature	Sn-Pb Eutectic Assembly	Pb-Free Assembly
Average ramp-up rate (TL to TP)	3°C/second maximum	3°C/second maximum
Preheat - Temperature Minimum (TSMIN) - Temperature Maximum (TSMAX) - Time (Minimum to maximum) (ts)	100°C 150°C 60-120 seconds	150°C 200°C 60-180 seconds
TSMAX to TL - Ramp-up Rate	—	3°C/second maximum
Time Maintained above: - Temperature (TL) - Time (tL)	183°C 60-150 seconds	217°C 60-150 seconds
Peak Temperature (TP)	225 +0 / -5°C	245 +0 / -5°C
Time within 5°C of actual Peak Temperature (TP)	10-30 seconds	20-40 seconds
Ramp-down Rate	6°C/second maximum	6°C/second maximum
Time 25°C to Peak Temperature	6 minutes maximum	8 minutes maximum

**Graph1: Solder Re-Flow Time-Temperature Function**

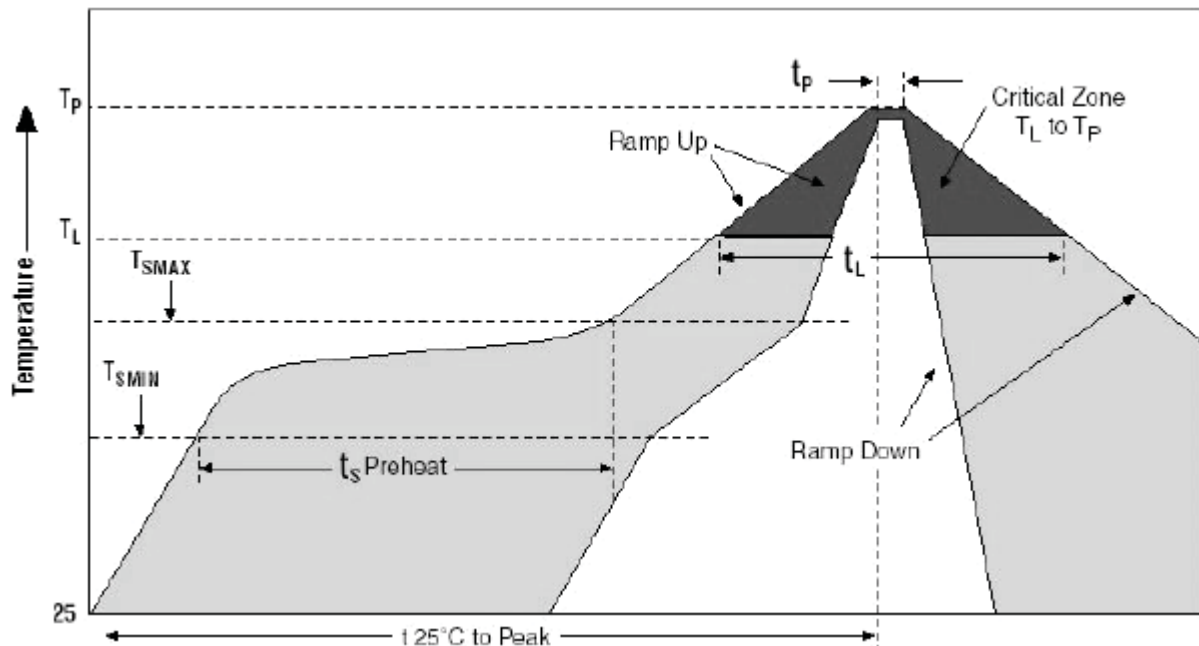

## Outline Drawing, Case Style 301 (CS301)

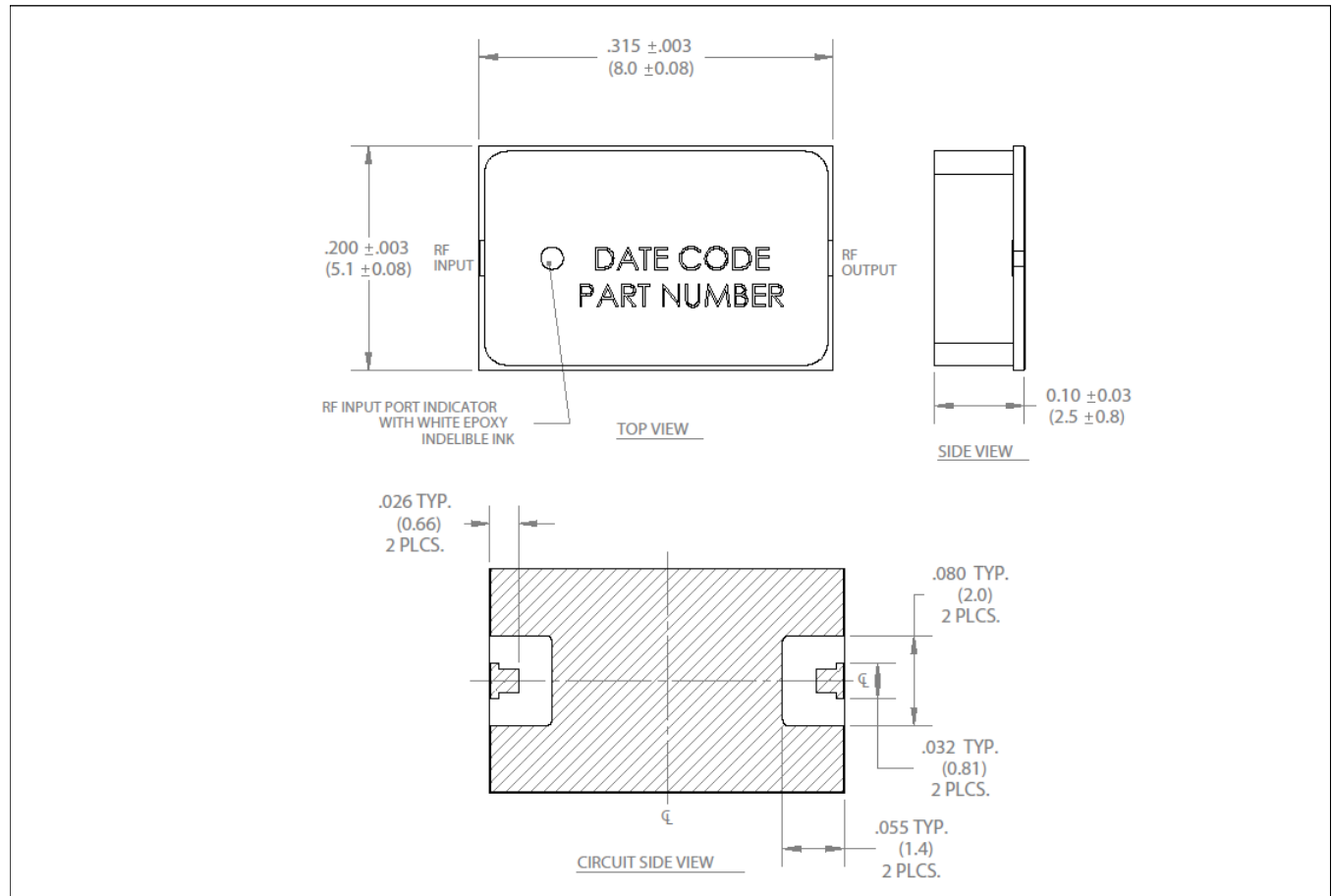

The hatched metal area on circuit side of device is RF and DC grounded.

Dimensions are in inches (mm)

Substrate Material: 20 mil thick Alumina Nitride (ALN)

RF Cover: Black Ceramic

Top Side and Backside Metallization: 100  $\mu$  IN. typical plated over Ti-Pd.

M/A-COM Technology Solutions Inc. All rights reserved.

Information in this document is provided in connection with M/A-COM Technology Solutions Inc ("MACOM") products. These materials are provided by MACOM as a service to its customers and may be used for informational purposes only. Except as provided in MACOM's Terms and Conditions of Sale for such products or in any separate agreement related to this document, MACOM assumes no liability whatsoever. MACOM assumes no responsibility for errors or omissions in these materials. MACOM may make changes to specifications and product descriptions at any time, without notice. MACOM makes no commitment to update the information and shall have no responsibility whatsoever for conflicts or incompatibilities arising from future changes to its specifications and product descriptions. No license, express or implied, by estoppel or otherwise, to any intellectual property rights is granted by this document.

THESE MATERIALS ARE PROVIDED "AS IS" WITHOUT WARRANTY OF ANY KIND, EITHER EXPRESS OR IMPLIED, RELATING TO SALE AND/OR USE OF MACOM PRODUCTS INCLUDING LIABILITY OR WARRANTIES RELATING TO FITNESS FOR A PARTICULAR PURPOSE, CONSEQUENTIAL OR INCIDENTAL DAMAGES, MERCHANTABILITY, OR INFRINGEMENT OF ANY PATENT, COPYRIGHT OR OTHER INTELLECTUAL PROPERTY RIGHT. MACOM FURTHER DOES NOT WARRANT THE ACCURACY OR COMPLETENESS OF THE INFORMATION, TEXT, GRAPHICS OR OTHER ITEMS CONTAINED WITHIN THESE MATERIALS. MACOM SHALL NOT BE LIABLE FOR ANY SPECIAL, INDIRECT, INCIDENTAL, OR CONSEQUENTIAL DAMAGES, INCLUDING WITHOUT LIMITATION, LOST REVENUES OR LOST PROFITS, WHICH MAY RESULT FROM THE USE OF THESE MATERIALS.

MACOM products are not intended for use in medical, lifesaving or life sustaining applications. MACOM customers using or selling MACOM products for use in such applications do so at their own risk and agree to fully indemnify MACOM for any damages resulting from such improper use or sale.