

GTRB266908FC

Thermally-Enhanced High Power RF GaN on SiC Amplifier, 630 W, 48 V, 2515 – 2675 MHz

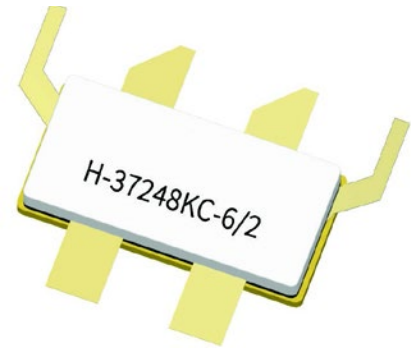

Package Types: H-37248KC-6/2
PN: GTRB266908FC

Description

The GTRB266908FC is a 630-watt (P4dB) GaN on SiC HEMT D-mode amplifier designed for use in multi-standard cellular power amplifier applications. It features high efficiency, and a thermally-enhanced package with earless flange.

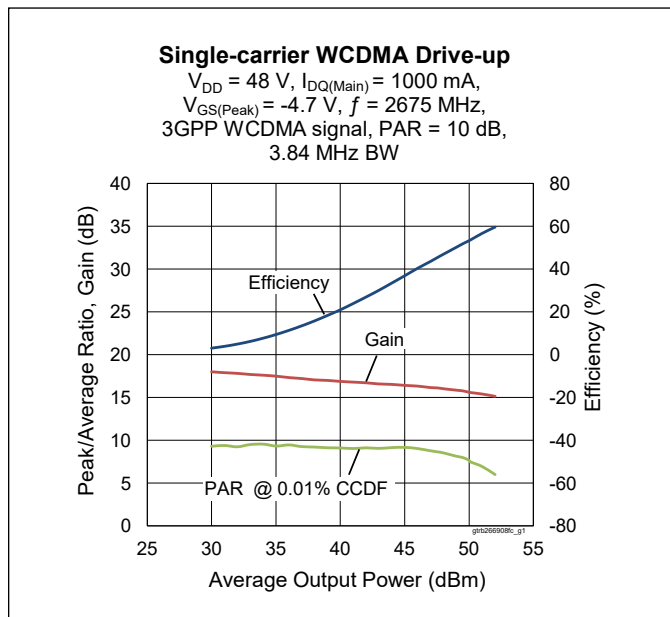

Features

- GaN on SiC HEMT technology
- Typical Pulsed CW performance, 2675 MHz, 48 V, 10 μs pulse width, 10% duty cycle, combined outputs
 - Output power at $P_{4\text{dB}} = 630\text{ W}$
 - Efficiency at $P_{4\text{dB}} = 73\%$
- Human Body Model Class 1B (per ANSI/ESDA/JEDEC JS-001)
- Pb-free and RoHS compliant

Typical RF Characteristics

Single-carrier WCDMA Specifications (tested in the Doherty evaluation board for 2515 – 2675 MHz)

$V_{DD} = 48\text{ V}$, $I_{DQ} = 1000\text{ mA}$, $P_{OUT} = 102.3\text{ W}$, $V_{GS(\text{peak})} = V_{GS}$ at $I_{DQ(\text{peak})} = 1000\text{ mA} - 1.7\text{ V}$, channel bandwidth = 3.84 MHz, peak/average = 10 dB @ 0.01% CCDF

	P_{OUT} (dBm)	Gain (dB)	Efficiency (%)	ACPR + (dBc)	ACPR - (dBc)	OPAR (dB)
2515 MHz	50.1	15.2	49.5	-31.3	-31.5	7.6
2595 MHz	50.1	15.9	49.9	-36.5	-36.3	7.7
2675 MHz	50.1	15.6	53	-34.6	-34.6	7.5

Note:

All published data at $T_{CASE} = 25^\circ\text{C}$ unless otherwise indicated
 ESD: Electrostatic discharge sensitive device—observe handling precautions!



DC Characteristics

Characteristic	Symbol	Min.	Typ.	Max.	Unit	Conditions
Drain-source Breakdown Voltage (main)	$V_{BR(DSS)}$	150	—	—	V	$V_{GS} = -8\text{ V}, I_D = 10\text{ mA}$
Drain-source Breakdown Voltage (peak)						
Drain-source Leakage Current (main)	I_{DSS}	—	—	5	mA	$V_{GS} = -8\text{ V}, V_{DS} = 10\text{ V}$
Drain-source Leakage Current (peak)				7.1		
Gate to Source Leakage Current (main)	I_{GSX}	—	—	-10	mA	$V_{GS} = -8\text{ V}, V_{DD} = 50\text{ V}$
Gate to Source Leakage Current (peak)				-15		
Gate Threshold Voltage (main)	$V_{GS(th)}$	-3.8	-3.05	-2.3	V	$V_{DS} = 10\text{ V}, I_D = 36\text{ mA}$
Gate Threshold Voltage (peak)						$V_{DS} = 10\text{ V}, I_D = 50\text{ mA}$

Recommended Operating Voltages

Parameter	Symbol	Min.	Typ.	Max.	Unit	Conditions
Drain Operating Voltage	V_{DD}	0	—	50	V	$V_{DS} = 48\text{ V}, I_D = 1000\text{ mA}$
Gate Quiescent Voltage	$V_{GS(Q)}$	-3.3	-2.8	-2.3		

Absolute Maximum Ratings

Parameter	Symbol	Value	Unit
Drain-source Voltage	V_{DSS}	125	V
Gate-source Voltage	V_{GS}	-10 to +2	
Operating Voltage	V_{DD}	55	
Gate Current (main)	I_G	36	mA
Gate Current (peak)		50.4	
Drain Current (main)	I_D	13.5	A
Drain Current (peak)		18.9	
Junction Temperature	T_J	275	°C
Storage Temperature Range	T_{STG}	-65 to +150	

1. Operation above the maximum values listed here may cause permanent damage. Maximum ratings are absolute ratings; exceeding only one of these values may cause irreversible damage to the component. Exposure to absolute maximum rating conditions for extended periods may affect device reliability. For reliable continuous operation, the device should be operated within the operating voltage range (V_{DD}) specified above.
2. Product's qualification were performed at 225 °C. Operation at T_J (275 °C) reduces median time to failure.

Thermal Characteristics

Parameter	Symbol	Value	Unit	Conditions
Thermal Resistance (main)	$R_{\theta JC}$	1.05	°C/W	$T_{CASE} = 85^\circ\text{C}, 134\text{ W DC}, 48\text{ V}$
Thermal Resistance (peak)		1.0		$T_{CASE} = 85^\circ\text{C}, 140\text{ W DC}, 48\text{ V}$

RF Characteristics

Single-carrier WCDMA Specifications (tested in the Doherty production test fixture)

$V_{DD} = 48\text{ V}$, $I_{DQ} = 1000\text{ mA}$, $P_{OUT} = 102.3\text{ W}$, $V_{GS(PEAK)} = V_{GS} @ I_{DQ(PEAK)} = 1000\text{ mA} - 1.7\text{ V}$, $f = 2675\text{ MHz}$, 3GPP signal, channel bandwidth = 3.84 MHz, peak/average = 10 dB @ 0.01% CCDF

Characteristic	Symbol	Min.	Typ.	Max.	Unit
Gain	G_{ps}	13	15	—	dB
Drain Efficiency	η_D	45	52	—	%
Adjacent Channel Power Ratio	ACPR	—	-34	-27	dBc
Output PAR @ 0.01% CCDF	OPAR	6.6	7.3	—	dB

Ordering Information

Type and Version	Order Code	Package	Shipping
GTRB266908FC V1 R0	GTRB266908FC-V1-R0	H-37248KC-6/2	Tape & Reel, 50 pcs
GTRB266908FC V1 R2	GTRB266908FC-V1-R2	H-37248KC-6/2	Tape & Reel, 250 pcs

Typical Performance (data taken in the Doherty evaluation board)

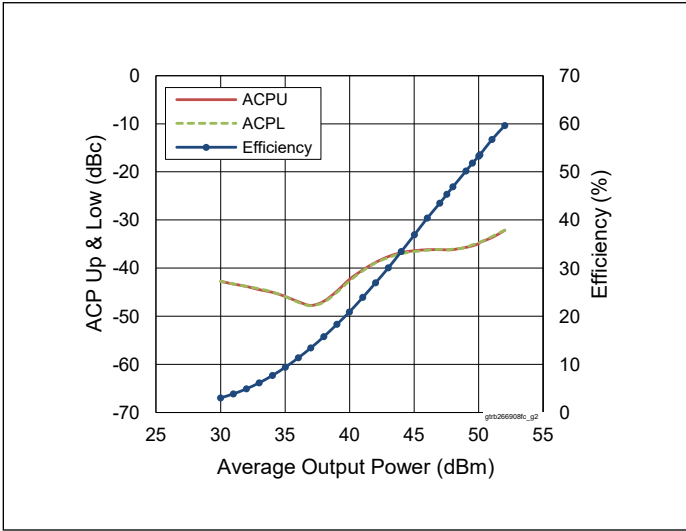

Figure 1. Single-carrier WCDMA Drive-up

$V_{DD} = 48\text{ V}$, $I_{DQ(\text{Main})} = 1000\text{ mA}$,
 $V_{GS(\text{Peak})} = -4.7\text{ V}$, $f = 2675\text{ MHz}$,
 3GPP WCDMA signal, PAR = 10 dB,
 BW = 3.84 MHz

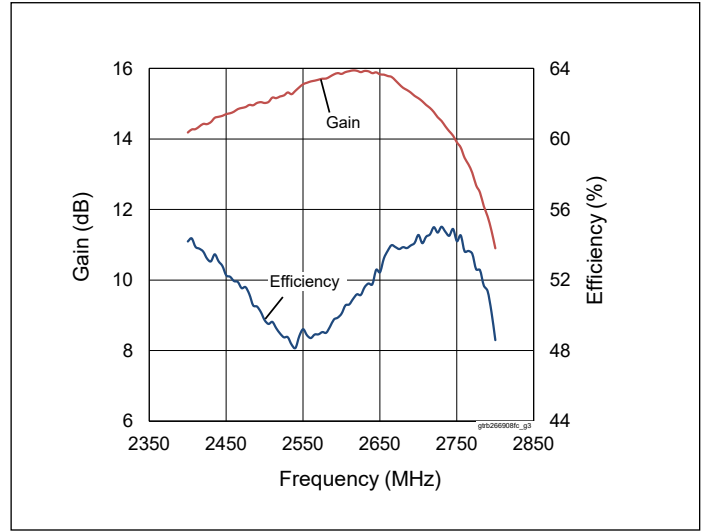

Figure 2. Single-carrier WCDMA Broadband

$V_{DD} = 48\text{ V}$, $I_{DQ(\text{Main})} = 1000\text{ mA}$,
 $V_{GS(\text{Peak})} = -4.7\text{ V}$, $P_{OUT} = 50.1\text{ dBm}$,
 3GPP WCDMA signal, PAR = 10 dB

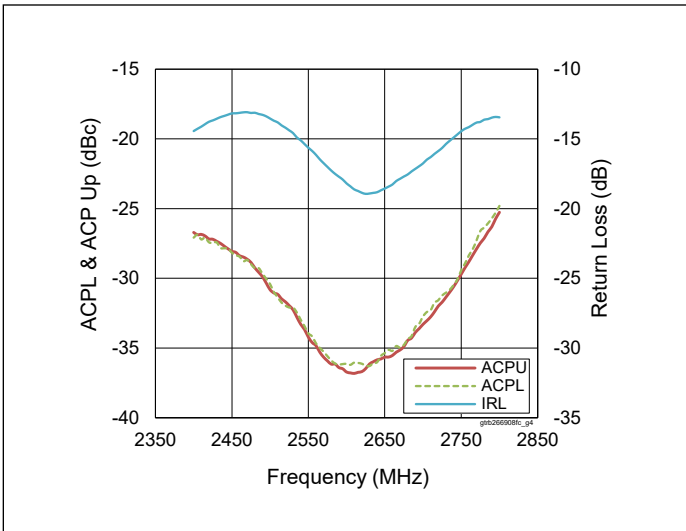

Figure 3. Single-carrier WCDMA Broadband

$V_{DD} = 48\text{ V}$, $I_{DQ(\text{Main})} = 1000\text{ mA}$,
 $V_{GS(\text{Peak})} = -4.7\text{ V}$, $P_{OUT} = 50.1\text{ dBm}$,
 3GPP WCDMA signal, PAR = 10 dB

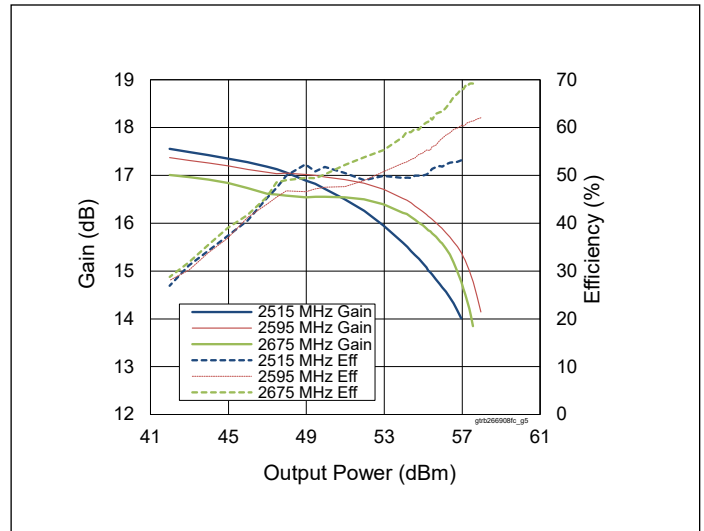

Figure 4. Pulsed CW Performance

$V_{DD} = 48\text{ V}$, $I_{DQ(\text{Main})} = 1000\text{ mA}$,
 $V_{GS(\text{Peak})} = -4.5\text{ V}$

Typical Performance (cont.)

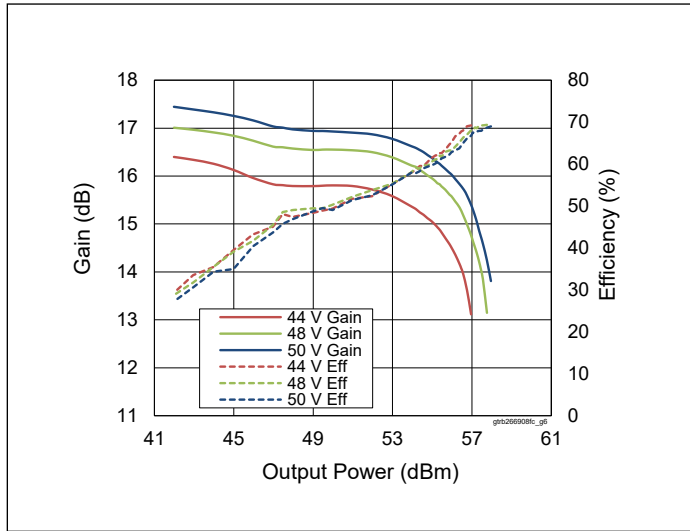

Figure 5. Pulsed CW Performance at various V_{DD}

$I_{DQ(Main)} = 1000\text{ mA}$, $V_{GS(Peak)} = -4.5\text{ V}$,
 $f = 2675\text{ MHz}$

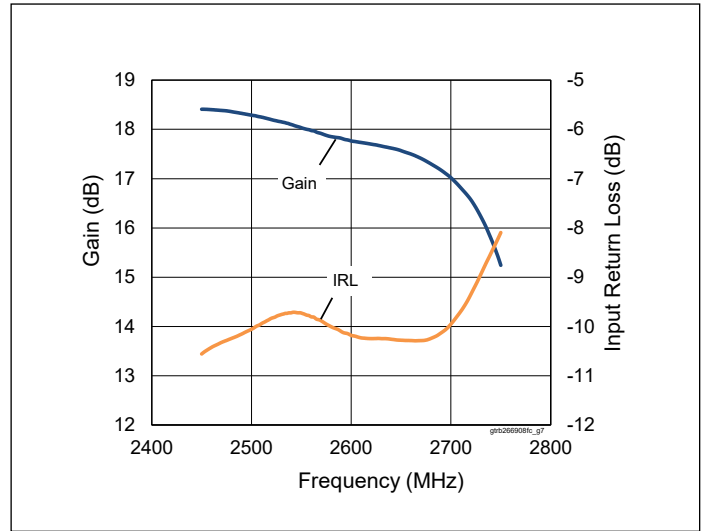

Figure 6. Small Signal CW Gain & Input Return Loss

$V_{DD} = 48\text{ V}$, $I_{DQ(Main)} = 1000\text{ mA}$,
 $V_{GS(Peak)} = -4.7\text{ V}$

Load Pull Performance

Main side load pull performance – Pulsed CW signal: 10 μsec , 10% duty cycle, 48 V, $I_{DQ} = 150\text{ mA}$, class AB

Freq [MHz]	Z_s [Ω]	Z_1 [Ω]	P_{3dB}								
			Max Output Power				Max Drain Efficiency				
			Gain [dB]	P_{3dB} [dBm]	P_{3dB} [W]	η_D [%]	Z_1 [Ω]	Gain [dB]	P_{3dB} [dBm]	P_{3dB} [W]	η_D [%]
2495	3.25-j12.23	3.07-j5.41	16.15	55.95	393.55	67.77	3.86-j3.2	17.63	54.92	310.46	77.74
2515	5.45-j13	2.65-j4.61	16.20	55.87	386.37	68.09	3.98-j2.04	17.85	53.95	248.31	77.58
2595	7.6-j14.54	3.1-j5.27	16.33	55.75	375.84	69.94	3.12-j1.98	18.24	53.26	211.84	78.24
2675	12.5-j7.1	2.65-j5.32	16.12	55.65	367.28	66.90	3.03-j2.96	17.68	54.08	255.86	79.48
2690	13.1-j8.42	2.65-j5.32	16.29	55.63	365.59	67.48	3.64-j2.6	17.56	53.23	210.38	78.99

Peak side load pull performance – Pulsed CW signal: 10 μsec , 10% duty cycle, 48 V, $V_{GSPK} = -3.3\text{ V}$, class B

Freq [MHz]	Z_s [Ω]	Z_1 [Ω]	P_{3dB}								
			Max Output Power				Max Drain Efficiency				
			Gain [dB]	P_{3dB} [dBm]	P_{3dB} [W]	η_D [%]	Z_1 [Ω]	Gain [dB]	P_{3dB} [dBm]	P_{3dB} [W]	η_D [%]
2495	2.24-j12.69	1.63-j3.08	15.57	57.33	540.75	67.39	1.48-j1.86	17.16	55.72	373.25	75.60
2515	2.67-j12.7	2.03-j3.12	15.08	57.12	515.23	63.37	1.48-j1.86	16.57	56.05	402.72	75.90
2595	2.83-j13.55	1.85-j3.51	15.31	57.15	518.80	62.86	1.58-j2.27	16.87	56.04	401.79	75.31
2675	5.03-j13.21	1.71-j3.49	15.38	57.13	516.42	64.04	1.3-j2.37	17.00	55.71	372.39	74.69
2690	5.7-j13.5	1.54-j3.74	15.44	57.18	522.40	64.63	1.41-j2.65	17.01	55.94	392.64	75.04

Doherty Evaluation Board, 2515 – 2675 MHz

Evaluation Board Part Number	LTA/GTRB266908FC-E2
PCB Information	Rogers 4350, 0.508 mm [0.020"] thick, 2 oz. copper, $\epsilon_r = 3.66$

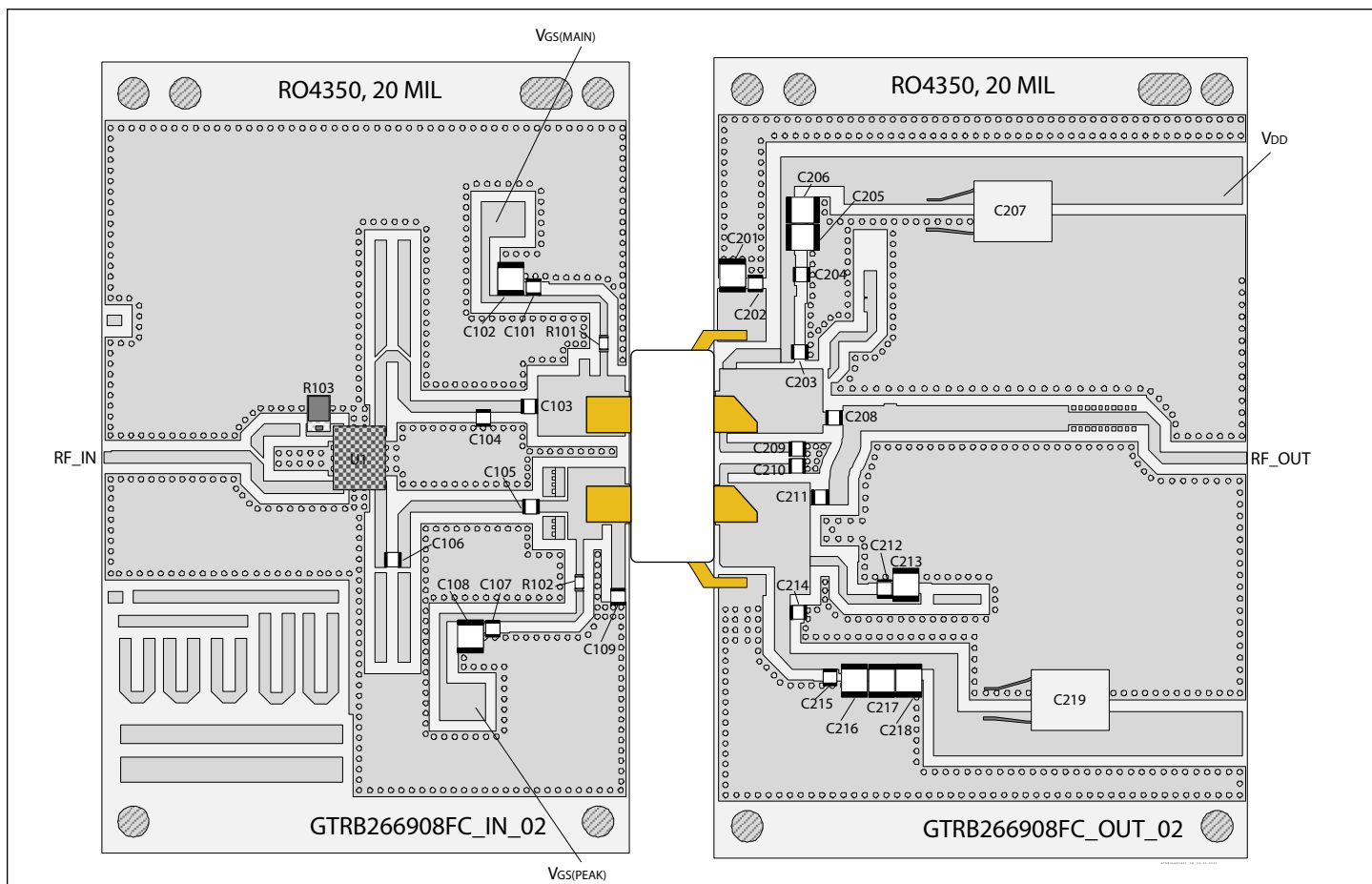

Application circuit assembly diagram (not to scale)

Components Information

Component	Description	Manufacturer	P/N
Input			
C101, C107	Capacitor, 18 pF	ATC	ATC600F180JT250XT
C102, C108	Capacitor, 10 μ F	Murata Electronics	GRM32EC72A106KE05L
C103, C105, C106	Capacitor, 10 pF	ATC	ATC600F100JT250XT
C104, C109	Capacitor, 0.5 pF	ATC	ATC600F0R5BT250XT
R101, R102	Resistor, 5.6 ohms	Panasonic Electronic Components	ERJ-3GEYJ5R6V
R103	Resistor, 50 ohms	Richardson	C8A50Z4B
U1	Hybrid Coupler	Anaren	X3C26P1-03S
Output			
C201, C205, C206, C213, C216, C217, C218	Capacitor, 10 μ F	Murata Electronics	GRM32EC72A106KE05L
C202	Capacitor, 10000 pF	ATC	PCC1991CT-ND
C203	Capacitor, 0.2 pF	ATC	ATC600F0R2BT250XT
C204, C212, C215	Capacitor, 18 pF	ATC	ATC600F180JT250XT
C207, C219	Capacitor, 470 μ F	Panasonic Electronic Components	ECA-2AHG471B
C208	Capacitor, 2.4 pF	ATC	ATC600F2R4BT250XT
C209	Capacitor, 0.5 pF	ATC	ATC600F0R5BT250XT
C210	Capacitor, 0.7 pF	ATC	ATC600F0R7BT250XT
C211	Capacitor, 10 pF	ATC	ATC600F100JT250XT
C214	Capacitor, 0.9 pF	ATC	ATC600F0R9BT250XT

Bias Sequencing

Bias ON

1. Ensure RF is turned off
2. Apply pinch-off voltage of -5 V to the gate
3. Apply nominal drain voltage
4. Bias gate to desired quiescent drain current
5. Apply RF

Bias OFF

1. Turn RF off
2. Apply pinch-off voltage to the gate
3. Turn-off drain voltage
4. Turn-off gate voltage

Pinout Diagram

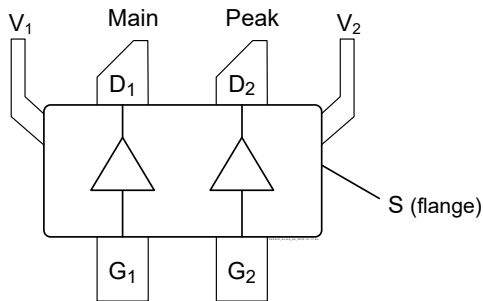

Pin	Description
D1	Drain Device 1 (Main)
D2	Drain Device 2 (Peak)
G1	Gate Device 1 (Main)
G2	Gate Device 2 (Peak)
V1	Drain video decoupling and no DC bias
V2	N.C (It is recommended to ground this pin)
S	Source (flange)

Lead connections for GTRB266908FC

Notes & Disclaimer

MACOM Technology Solutions Inc. ("MACOM"). All rights reserved.

These materials are provided in connection with MACOM's products as a service to its customers and may be used for informational purposes only. Except as provided in its Terms and Conditions of Sale or any separate agreement, MACOM assumes no liability or responsibility whatsoever, including for (i) errors or omissions in these materials; (ii) failure to update these materials; or (iii) conflicts or incompatibilities arising from future changes to specifications and product descriptions, which MACOM may make at any time, without notice. These materials grant no license, express or implied, to any intellectual property rights.

THESE MATERIALS ARE PROVIDED "AS IS" WITH NO WARRANTY OR LIABILITY, EXPRESS OR IMPLIED, RELATING TO SALE AND/OR USE OF MACOM PRODUCTS INCLUDING FITNESS FOR A PARTICULAR PURPOSE, MERCHANTABILITY, INFRINGEMENT OF INTELLECTUAL PROPERTY RIGHT, ACCURACY OR COMPLETENESS, OR SPECIAL, INDIRECT, INCIDENTAL, OR CONSEQUENTIAL DAMAGES WHICH MAY RESULT FROM USE OF THESE MATERIALS.

MACOM products are not intended for use in medical, lifesaving or life sustaining applications. MACOM customers using or selling MACOM products for use in such applications do so at their own risk and agree to fully indemnify MACOM for any damages resulting from such improper use or sale.