

Active Double Balanced Mixer

0.1 - 6 GHz



CGY2183UH/C1

Rev. V1

Features

- RF and LO Range: 0.1 - 6.0 GHz
- IF Range: DC - 3 GHz
- Conversion Gain: 11 dB
- RF to IF Leakage: -35 dB
- LO to IF Isolation: 35 dB
- Output P1dB: -5 dBm
- Small Chip Size: 1.1 x 1.7 x 0.1 mm
- Tested, Inspected Known Good Die (KGD)
- Evaluation Boards Available
- Space and MIL-STD also Available
- RoHS* Compliant

Applications

- GPS Systems
- Radar
- Telecommunication
- Instrumentation

Description

The CGY2183UH/C1 is a high performance GaAs pHEMT technology based active double balanced mixer MMIC. This device covers the frequency range of 0.1 GHz to 6 GHz, with a conversion gain of typically 11 dB, and uses an active Gilbert Cell Mixer Structure.

The die is manufactured using 0.18 μm gate length pHEMT Technology ED02AH. The MMIC uses gold bond pads and backside metallization and is fully protected with Silicon Nitride passivation to obtain the highest level of reliability.

Block Diagram

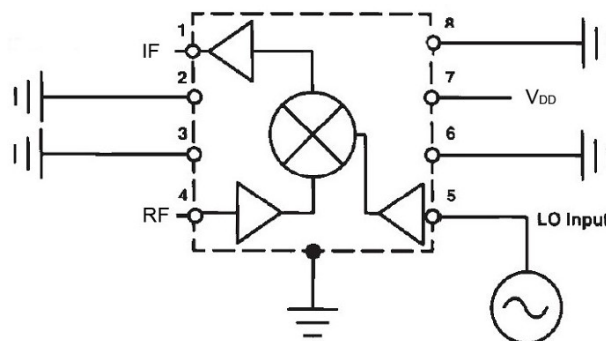

Ordering Information

Part Number	Package
CGY2183UH/C1	Active double balanced quad mixer

* Restrictions on Hazardous Substances, compliant to current RoHS EU directive.

Active Double Balanced Mixer

0.1 - 6 GHz



CGY2183UH/C1

Rev. V1

**Electrical Specifications: Down Converter Mode, Measured on Wafer,
Freq.: RF = 2.2 GHz, IF = 30 MHz, LO Power = -5 dBm**

Parameter	Test Conditions	Units	Min.	Typ.	Max.
Supply Voltage	—	V	—	7	—
Supply Current	—	mA	17	21	25
Conversion Gain	—	dB	9	11	14
SSB Noise Figure	—	dB	—	8	—
Leakage	RF to IF	dBc	—	-35	-30
Isolation	LO to IF	dB	30	35	—
Input P1dB	—	dBm	-7	-5	—

Absolute Maximum Ratings^{1,2}

Parameter	Absolute Maximum
Supply Voltage	9 V
LO Input Power	0 dBm
Junction Temperature	+150°C
Operating Temperature	-30°C to +85°C
Storage Temperature	-55°C to +150°C

1. Exceeding any one or combination of these limits may cause permanent damage to this device.
2. MACOM does not recommend sustained operation near these survivability limits.

Handling Procedures

Please observe the following precautions to avoid damage:

Static Sensitivity

These electronic devices are sensitive to electrostatic discharge (ESD) and can be damaged by static electricity. Proper ESD control techniques should be used when handling these devices.

Active Double Balanced Mixer

0.1 - 6 GHz



CGY2183UH/C1
Rev. V1

Typical Performance Curves: Down Conversion Mode

Conversion Gain vs. RF Frequency, IF = 30 MHz

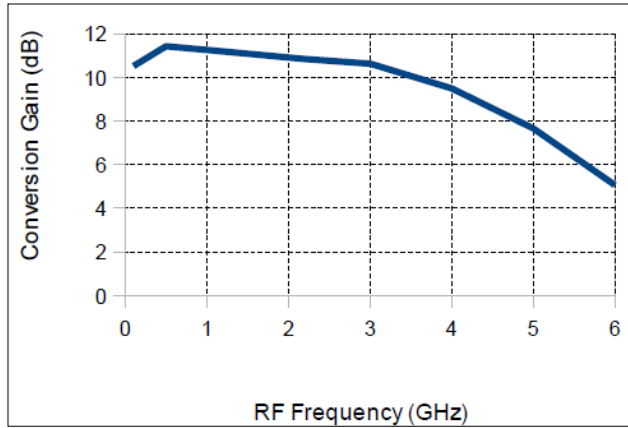

Conversion Gain vs. RF Frequency, RF = 2.2 GHz

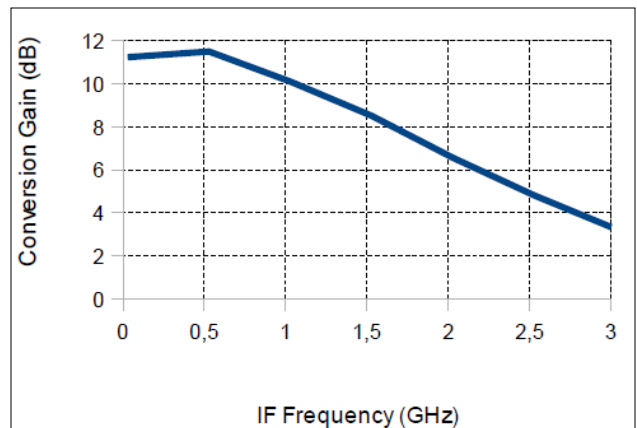

LO to IF Leakage vs. RF Frequency, IF = 30 MHz

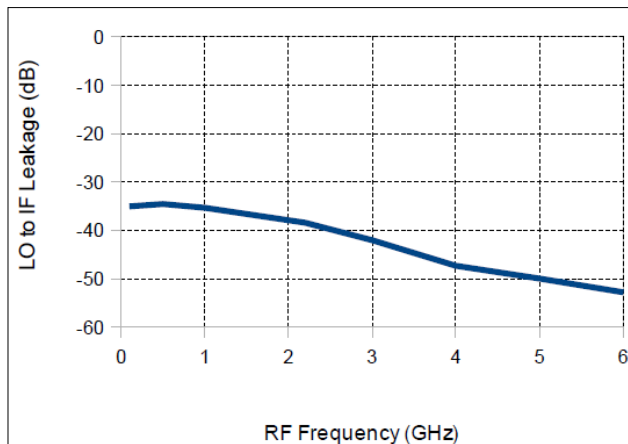

RF Power on IF Port vs. RF Frequency, IF = 30 MHz

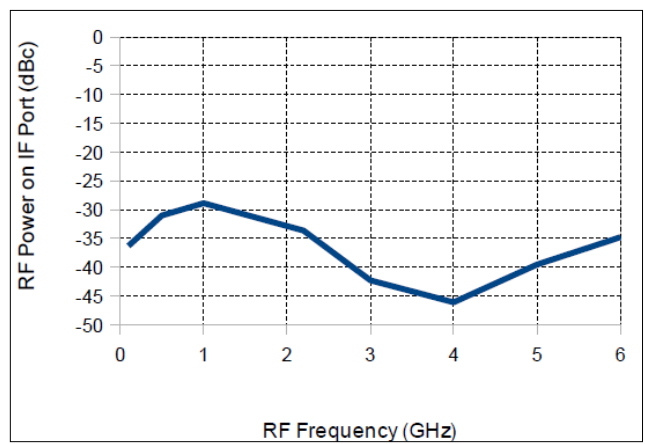

P1dB & Gain Variation vs. Input RF Power Level,
IF = 30 MHz RF = 2.2 GHz LO = 2.23 GHz

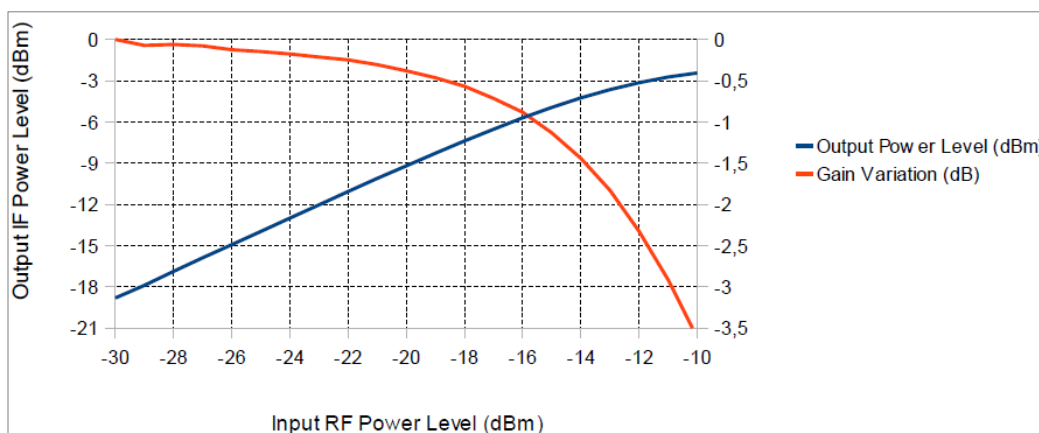

3

MACOM Technology Solutions Inc. (MACOM) and its affiliates reserve the right to make changes to the product(s) or information contained herein without notice. Visit www.macom.com for additional data sheets and product information.

For further information and support please visit:
<https://www.macom.com/support>

DC-0029688

Active Double Balanced Mixer

0.1 - 6 GHz



CGY2183UH/C1
Rev. V1

Block Diagram

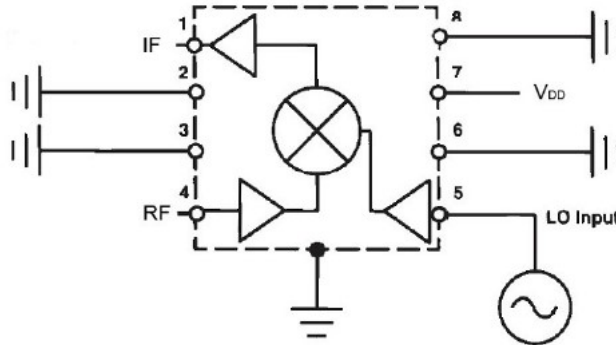

Pad Position

Pad Name	Coordinate		Description
	X (μm)	Y (μm)	
LO	1580	180	Local Oscillator Input
RF	120	550	RF Input
IF	120	920	IF Output
VD	1580	980	Supply Voltage

X=0, Y=0 at bottom left corner.
Co-ordinates correspond to the center of the bonding pad.
See Mechanical Information for more details.

Assembly Information

The bonding wires should be gold and be as short as possible. The CGY2183UH/C1 uses through substrate via holes to obtain excellent RF grounding. The backside of the MMIC must be appropriately connected to the system ground.

Active Double Balanced Mixer

0.1 - 6 GHz



CGY2183UH/C1

Rev. V1

Mechanical Information

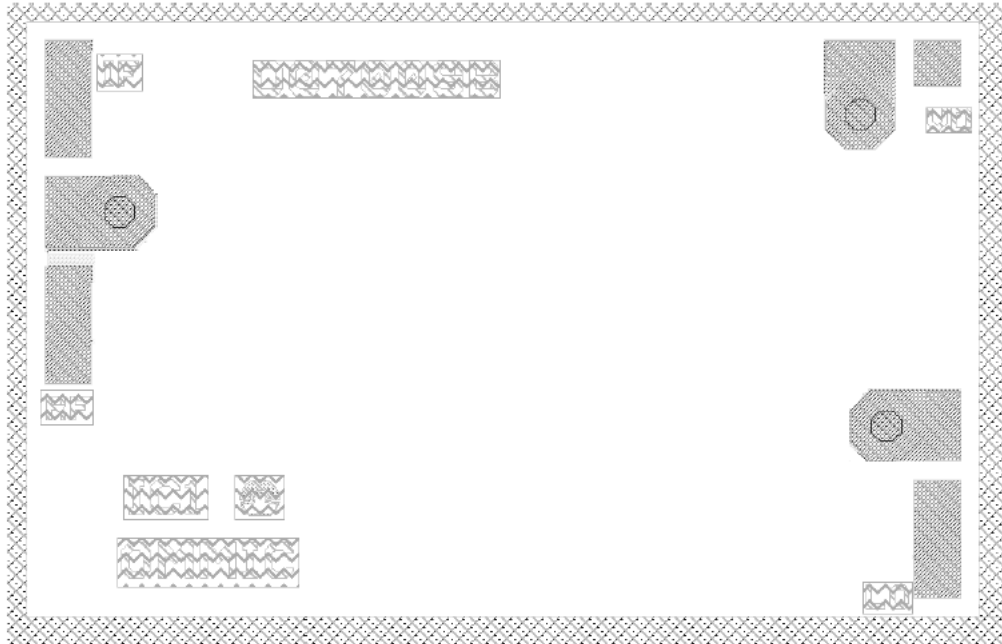

Chip Size: 1100 μm x 1700 μm (before wafer sawing)
Substrate Thickness: 100 μm
RF, IF, & LO: 80 x 200 μm
DC Pads Size: 80 x 80 μm

Active Double Balanced Mixer

0.1 - 6 GHz



CGY2183UH/C1

Rev. V1

MACOM Technology Solutions Inc. ("MACOM"). All rights reserved.

These materials are provided in connection with MACOM's products as a service to its customers and may be used for informational purposes only. Except as provided in its Terms and Conditions of Sale or any separate agreement, MACOM assumes no liability or responsibility whatsoever, including for (i) errors or omissions in these materials; (ii) failure to update these materials; or (iii) conflicts or incompatibilities arising from future changes to specifications and product descriptions, which MACOM may make at any time, without notice. These materials grant no license, express or implied, to any intellectual property rights.

THESE MATERIALS ARE PROVIDED "AS IS" WITH NO WARRANTY OR LIABILITY, EXPRESS OR IMPLIED, RELATING TO SALE AND/OR USE OF MACOM PRODUCTS INCLUDING FITNESS FOR A PARTICULAR PURPOSE, MERCHANTABILITY, INFRINGEMENT OF INTELLECTUAL PROPERTY RIGHT, ACCURACY OR COMPLETENESS, OR SPECIAL, INDIRECT, INCIDENTAL, OR CONSEQUENTIAL DAMAGES WHICH MAY RESULT FROM USE OF THESE MATERIALS.

MACOM products are not intended for use in medical, lifesaving or life sustaining applications. MACOM customers using or selling MACOM products for use in such applications do so at their own risk and agree to fully indemnify MACOM for any damages resulting from such improper use or sale.