

CGH55015F2/P2

10 W, C-Band, Unmatched, GaN HEMT

Description

The CGH55015F2/P2 is a gallium nitride (GaN) high electron mobility transistor (HEMT) designed specifically for high efficiency, high gain and wide bandwidth capabilities, which makes the CGH55015F2/P2 ideal for C-band pulsed or CW saturated amplifiers. The transistor is available in both screwdown, flange and solder-down, pill packages. Based on appropriate external match adjustment, the CGH55015F2/P2 is suitable for applications up to 6 GHz.

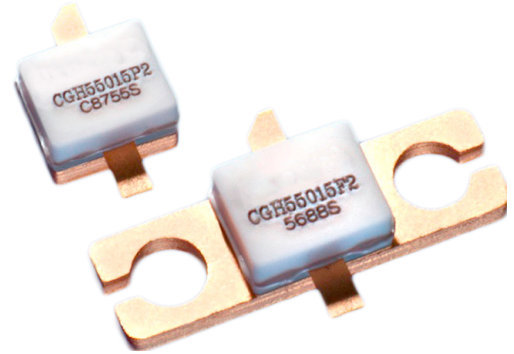

Package Types: 440196 & 440166
PNs: CGH55015P2 & CGH55015F2

Features

- 4.5 to 6.0 GHz Operation
- 12 dB Small Signal Gain at 5.65 GHz
- 13 W typical P_{SAT}
- 60% Efficiency at P_{SAT}
- 28 V Operation

Applications

- 2-Way Private Radio
- Broadband Amplifiers
- Cellular Infrastructure
- Test Instrumentation
- Class A, AB, Amplifiers suitable for OFDM, W-CDMA, EDGE, CDMA waveforms

 **Large Signal Models Available for ADS and MWO**



Absolute Maximum Ratings (not simultaneous) at 25°C Case Temperature

Parameter	Symbol	Rating	Units	Conditions
Drain-Source Voltage	V_{DSS}	120	V	25°C
Gate-to-Source Voltage	V_{GS}	-10, +2		
Storage Temperature	T_{STG}	-65, +150	°C	
Operating Junction Temperature	T_J	225		
Maximum Forward Gate Current	I_{GMAX}	4.0	mA	25°C
Maximum Drain Current ¹	I_{DMAX}	1.5	A	
Soldering Temperature ²	T_S	245	°C	
Screw Torque	τ	40	in-oz	
Thermal Resistance, Junction to Case ³	$R_{\theta JC}$	8.0	°C/W	85°C
Case Operating Temperature ^{3,4}	T_C	-40, +150	°C	30 seconds

Notes:

¹ Current limit for long term, reliable operation

² Refer to the Application Note on soldering

³ Measured for the CGH55015 at $P_{DISS} = 14$ W

⁴ See also, the Power Dissipation De-rating Curve on Page 5

Electrical Characteristics ($T_C = 25^\circ\text{C}$)

Characteristics	Symbol	Min.	Typ.	Max.	Units	Conditions
DC Characteristics¹						
Gate Threshold Voltage	$V_{GS(th)}$	-3.8	-3.0	-2.3	V_{DC}	$V_{DS} = 10$ V, $I_D = 3.6$ mA
Gate Quiescent Voltage	$V_{GS(Q)}$	—	-2.7	—		$V_{DS} = 28$ V, $I_D = 200$ A
Saturated Drain Current	I_{DS}	2.9	3.5	—	A	$V_{DS} = 6.0$ V, $V_{GS} = 2.0$ V
Drain-Source Breakdown Voltage	V_{BR}	84	—	—	V_{DC}	$V_{GS} = -8$ V, $I_D = 3.6$ mA
RF Characteristics² ($T_C = 25^\circ\text{C}$, $F_0 = 5.65$ GHz unless otherwise noted)						
Small Signal Gain	G_{SS}	10	12	—	dB	$V_{DD} = 28$ V, $I_{DQ} = 200$ mA
Output Power ³	P_{SAT}		12.5	—		
Drain Efficiency ⁴	η	50	60	—	%	$V_{DD} = 28$ V, $I_{DQ} = 200$ mA, $P_{OUT} = 10$ W
Output Mismatch Stress	VSWR	—	—	10 : 1	Ψ	No damage at all phase angles, $V_{DD} = 28$ V, $I_{DQ} = 200$ mA, $P_{OUT} = 10$ W CW
Dynamic Characteristics						
Input Capacitance	C_{GS}	—	4.5	—	pF	$V_{DS} = 28$ V, $V_{GS} = -8$ V, $f = 1$ MHz
Output Capacitance	C_{DS}	—	1.3	—		
Feedback Capacitance	C_{GD}	—	0.2	—		

Notes:

¹ Measured on wafer prior to packaging

² Measured in the CGH55015-AMP

³ P_{SAT} is defined as $I_G = 0.36$ mA

⁴ Drain Efficiency = P_{OUT}/P_{DC}

Typical Performance

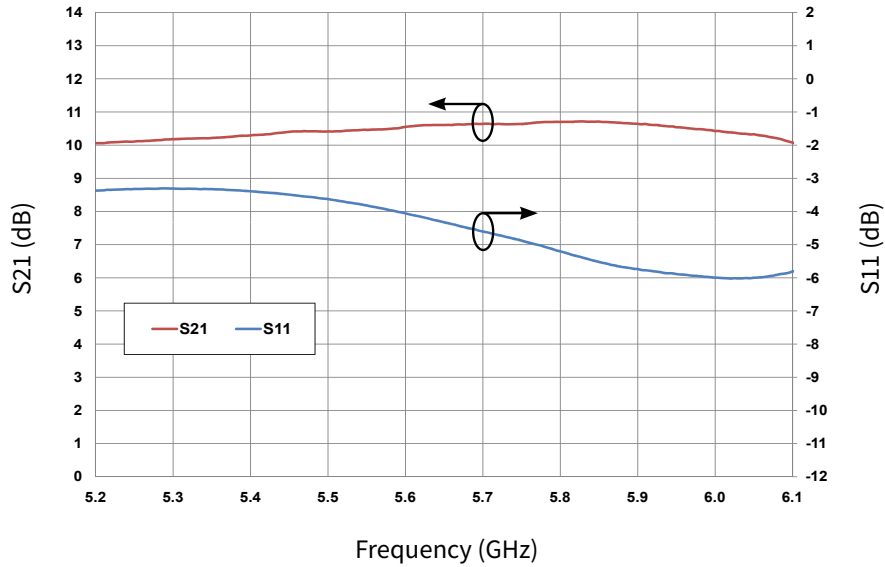

Figure 1. Small Signal S-Parameters vs Frequency of CGH55015F2 and CGH55015P2 in the CGH55015-AMP
 $V_{DD} = 28\text{ V}$, $I_{DQ} = 200\text{ mA}$

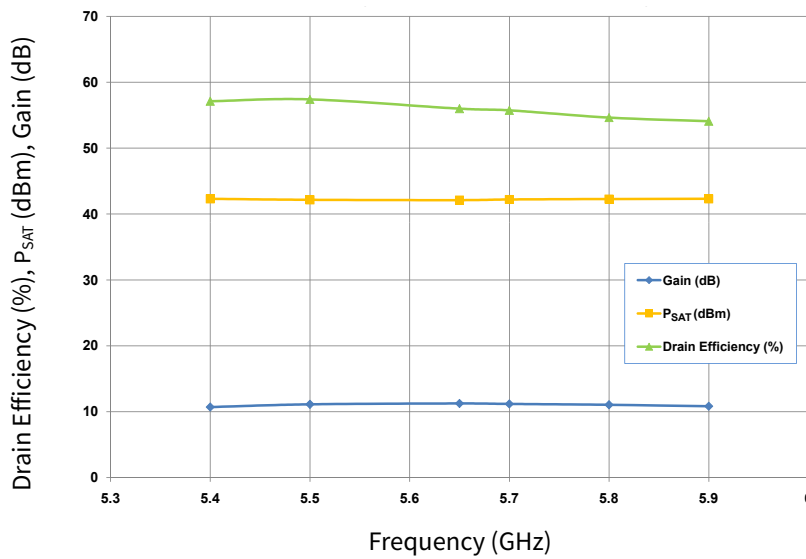

Figure 2. Drain Efficiency, Power and Gain vs Frequency of the CGH55015F2 and CGH55015P2 in the CGH55015-AMP
 $V_{DD} = 28\text{ V}$, $I_{DQ} = 200\text{ mA}$

Typical Performance

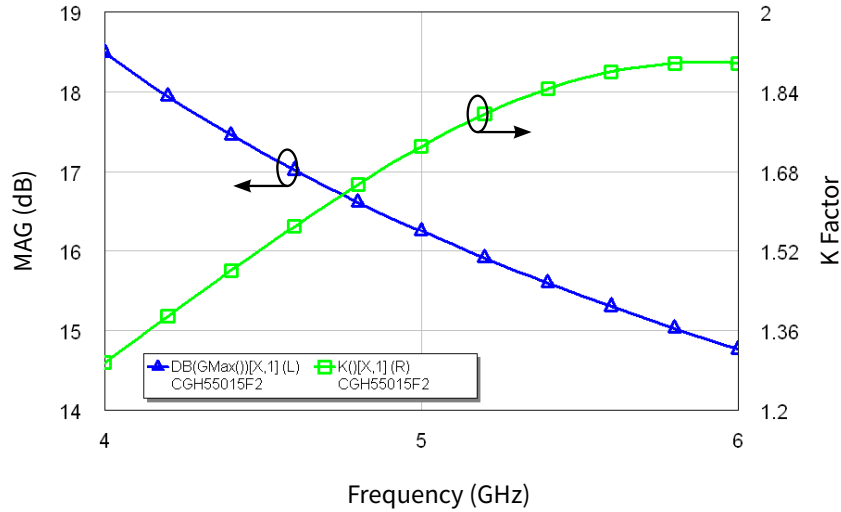

Figure 3. Simulated Maximum Available Gain and K Factor of the CGH55015F2 and CGH55015P2
 $V_{DD} = 28\text{ V}$, $I_{DQ} = 200\text{ mA}$

Typical Noise Performance

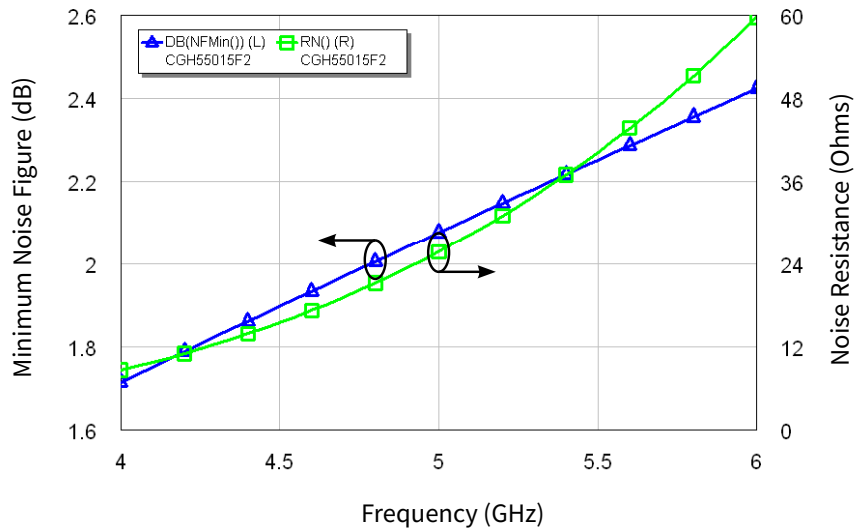
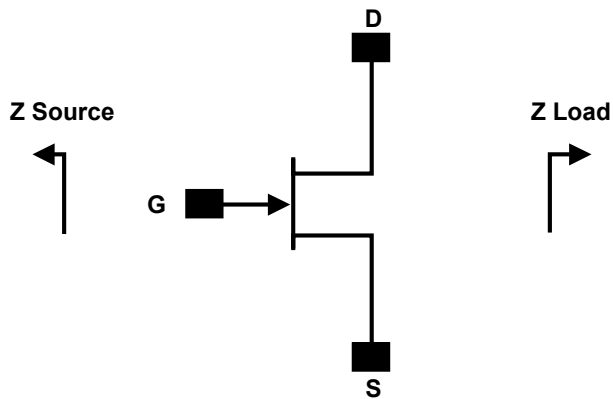

Figure 4. Simulated Minimum Noise Figure and Noise Resistance vs Frequency of the CGH55015F2 and CGH55015P2
 $V_{DD} = 28\text{ V}$, $I_{DQ} = 200\text{ mA}$

Electrostatic Discharge (ESD) Classifications

Parameter	Symbol	Class	Classification Level	Test Methodology
Human Body Model	HBM	0 (< 200V)	ANSI/ESDA/JEDEC JS-001 Table 3	JEDEC JESD22 A114-D
Charge Device Model	CDM	C3	ANSI/ESDA/JEDEC JS-002 Table 3	JEDEC JESD22 C101-C

Source and Load Impedances



Frequency (MHz)	Z Source	Z Load
5500	8.7 - j30.2	21.6 - j4.7
5650	10.2 - j26.9	24.2 - j5.5
5800	12.3 - j24.3	26.5 - j7.5

Notes:

¹ $V_{DD} = 28\text{ V}$, $I_{DQ} = 250\text{ mA}$ in the 440166 package

² Impedances are extracted from the CGH55015-AMP demonstration amplifier and are not source and load pull data derived from the transistor

CGH55015F2 and CGH55015P2 Transient Power Dissipation De-rating Curve

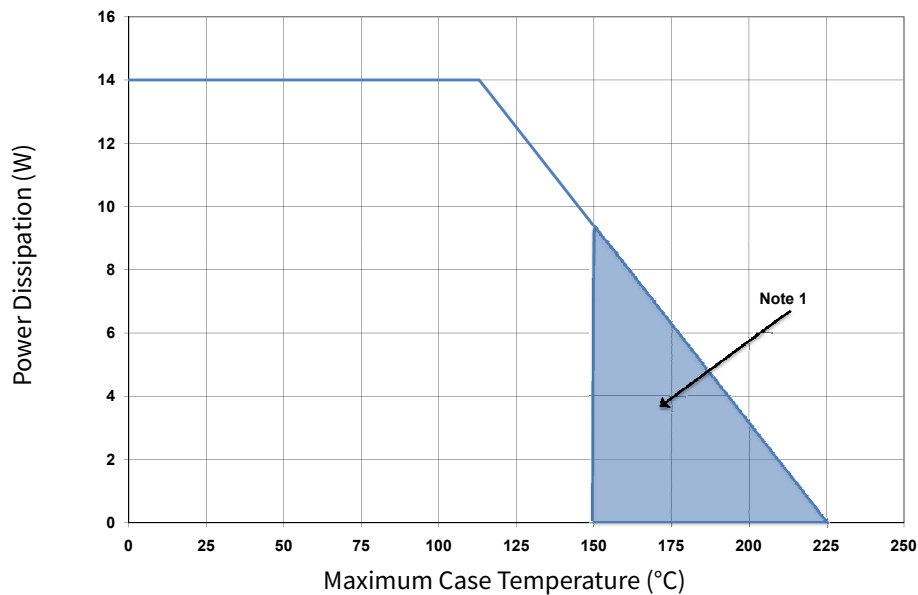

Note:

¹ Area exceeds Maximum Case Operating Temperature (See Page 2)

CGH55015-AMP Demonstration Amplifier Circuit Bill of Materials

Designator	Description	Qty
C1	CAP, 1.2pF, +/-0.1pF, 0603, ATC 600S	1
C2	CAP, 0.3pF, +/-0.05pF, 0402, ATC 600L	1
C9	CAP, 0.5pF, +/-0.05pF, 0603, ATC 600S	1
C4, C11	CAP, 18pF, +/-5%, 0603, ATC 600S	2
C5, C12	CAP, 39pF +/-5%, 0603, ATC 600S	2
C6, C13	CAP, CER, 180pF, 50V, +/-5%, C0G, 0603	2
C7, C14	CAP, CER, 0.1μF, 50V, +/-10%, X7R, 0805	2
C8	CAP, 10μF, 16V, SMT, TANTALUM	1
C15	CAP, 1.0μF, ±10%, 100V, 1210, X7R	1
C16	CAP, 33μF, 100V, ELECT, FK, SMD	1
R1	RES, 1/16W, 0603, 1%, 562 OHMS	1
R2	RES, 1/16W, 0603, 1%, 22 OHMS	1
J1	HEADER RT> PLZ .1 CEN LK 5 POS	1
J3, J4	CONN, SMA, FLANGE	2
—	PCB, RO4350B, Er = 3.48, h = 20 mil	1
—	CGH55015	1

CGH55015-AMP Demonstration Amplifier Circuit

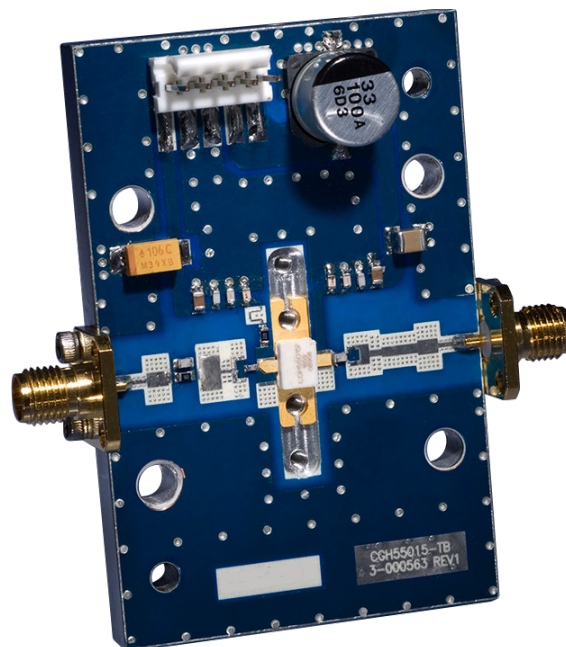

CGH55015-AMP Demonstration Amplifier Circuit Schematic

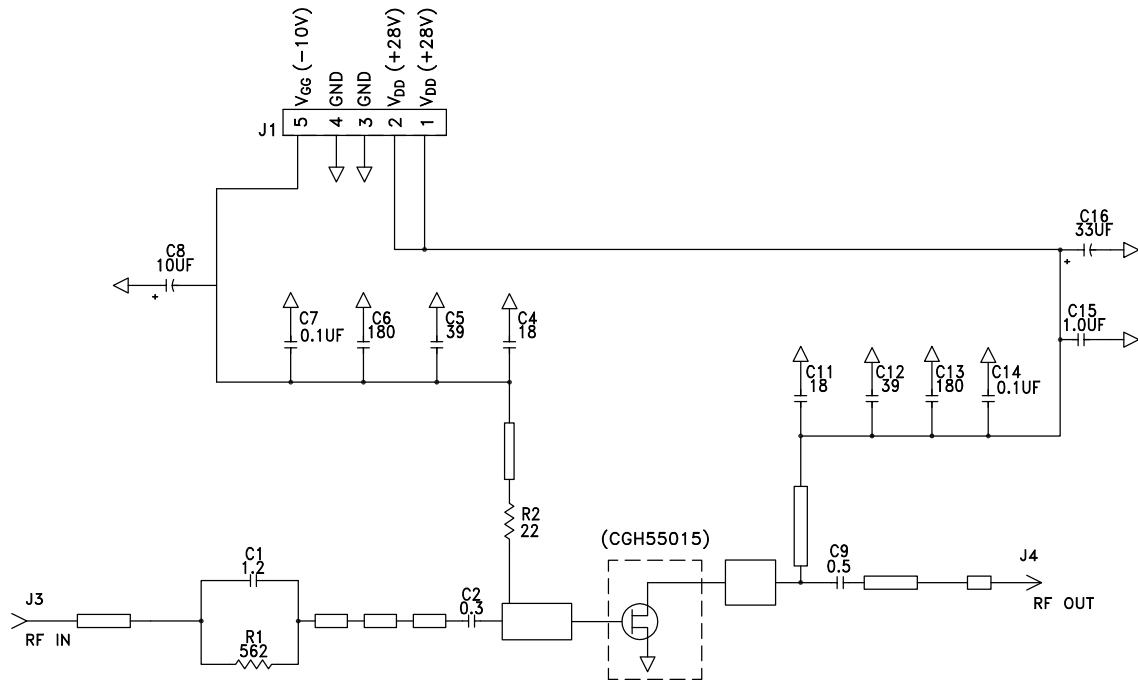

CGH55015-AMP Demonstration Amplifier Circuit Outline

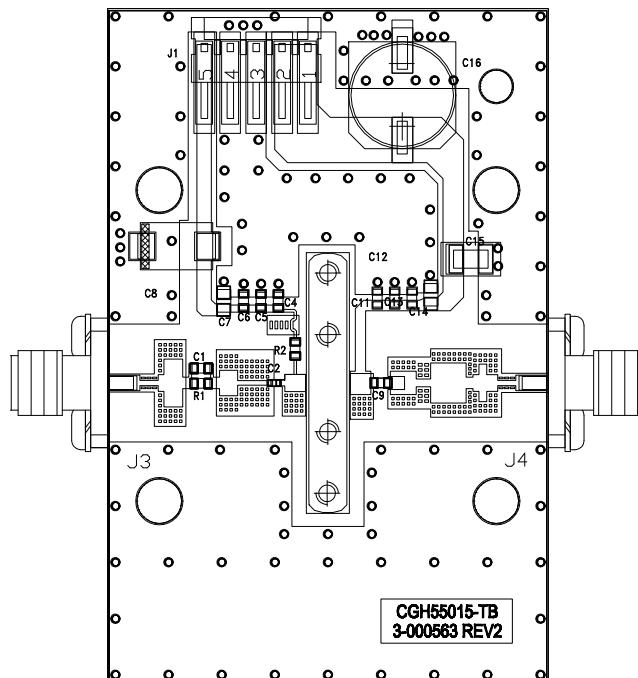

Typical Package S-Parameters for CGH55015F2/P2
(Small Signal, $V_{DS} = 28$ V, $I_{DQ} = 200$ A, angle in degrees)

Frequency	Mag S11	Ang S11	Mag S21	Ang S21	Mag S12	Ang S12	Mag S22	Ang S22
500 MHz	0.911	-130.86	18.44	105.32	0.022	19.38	0.302	-113.00
600 MHz	0.906	-139.86	15.82	99.40	0.023	14.28	0.299	-120.56
700 MHz	0.902	-146.89	13.81	94.44	0.023	10.15	0.298	-126.20
800 MHz	0.900	-152.58	12.23	90.14	0.023	6.68	0.299	-130.51
900 MHz	0.898	-157.33	10.97	86.29	0.023	3.69	0.302	-133.91
1.0 GHz	0.897	-161.38	9.93	82.79	0.023	1.03	0.305	-136.65
1.1 GHz	0.896	-164.92	9.06	79.53	0.023	-1.36	0.309	-138.93
1.2 GHz	0.895	-168.07	8.33	76.47	0.023	-3.55	0.314	-140.86
1.3 GHz	0.895	-170.92	7.71	73.56	0.023	-5.58	0.320	-142.55
1.4 GHz	0.895	-173.52	7.17	70.77	0.023	-7.47	0.326	-144.06
1.5 GHz	0.894	-175.93	6.70	68.08	0.023	-9.25	0.332	-145.44
1.6 GHz	0.894	-178.19	6.29	65.47	0.023	-10.93	0.338	-146.73
1.7 GHz	0.894	179.68	5.92	62.93	0.023	-12.52	0.345	-147.96
1.8 GHz	0.894	177.66	5.60	60.44	0.023	-14.04	0.351	-149.13
1.9 GHz	0.894	175.72	5.31	58.01	0.022	-15.49	0.358	-150.28
2.0 GHz	0.894	173.85	5.04	55.62	0.022	-16.88	0.365	-151.42
2.1 GHz	0.895	172.04	4.80	53.26	0.022	-18.21	0.372	-152.54
2.2 GHz	0.895	170.28	4.59	50.93	0.022	-19.48	0.379	-153.66
2.3 GHz	0.895	168.57	4.39	48.64	0.022	-20.69	0.386	-154.78
2.4 GHz	0.895	166.88	4.21	46.37	0.021	-21.85	0.393	-155.92
2.5 GHz	0.895	165.22	4.04	44.11	0.021	-22.96	0.400	-157.06
2.6 GHz	0.895	163.58	3.88	41.88	0.021	-24.02	0.407	-158.21
2.7 GHz	0.895	161.97	3.74	39.67	0.021	-25.02	0.413	-159.37
2.8 GHz	0.896	160.36	3.61	37.47	0.020	-25.97	0.420	-160.55
2.9 GHz	0.896	158.76	3.49	35.28	0.020	-26.87	0.426	-161.75
3.0 GHz	0.896	157.17	3.37	33.11	0.020	-27.72	0.433	-162.96
3.2 GHz	0.896	153.99	3.17	28.79	0.019	-29.24	0.445	-165.43
3.4 GHz	0.896	150.81	2.99	24.49	0.019	-30.53	0.456	-167.97
3.6 GHz	0.897	147.59	2.83	20.21	0.018	-31.57	0.467	-170.58
3.8 GHz	0.897	144.34	2.69	15.94	0.018	-32.35	0.477	-173.26
4.0 GHz	0.897	141.03	2.56	11.67	0.017	-32.86	0.487	-176.01
4.2 GHz	0.897	137.66	2.45	7.39	0.017	-33.08	0.496	-178.84
4.4 GHz	0.897	134.20	2.35	3.09	0.017	-33.02	0.504	178.25
4.6 GHz	0.897	130.65	2.26	-1.24	0.016	-32.67	0.511	175.25
4.8 GHz	0.897	127.01	2.18	-5.61	0.016	-32.06	0.517	172.16
5.0 GHz	0.896	123.25	2.11	-10.03	0.016	-31.23	0.523	168.97
5.2 GHz	0.896	119.37	2.04	-14.50	0.016	-30.22	0.528	165.68
5.4 GHz	0.896	115.36	1.98	-19.04	0.016	-29.11	0.532	162.26
5.6 GHz	0.896	111.21	1.92	-23.65	0.016	-27.99	0.536	158.72
5.8 GHz	0.895	106.92	1.87	-28.34	0.017	-26.98	0.539	155.04
6.0 GHz	0.895	102.47	1.83	-33.12	0.017	-26.15	0.541	151.21

To download the s-parameters in s2p format, go to the CGH55015F2/P2 Product page.

Product Dimensions CGH55015F2 (Package Type — 440166)

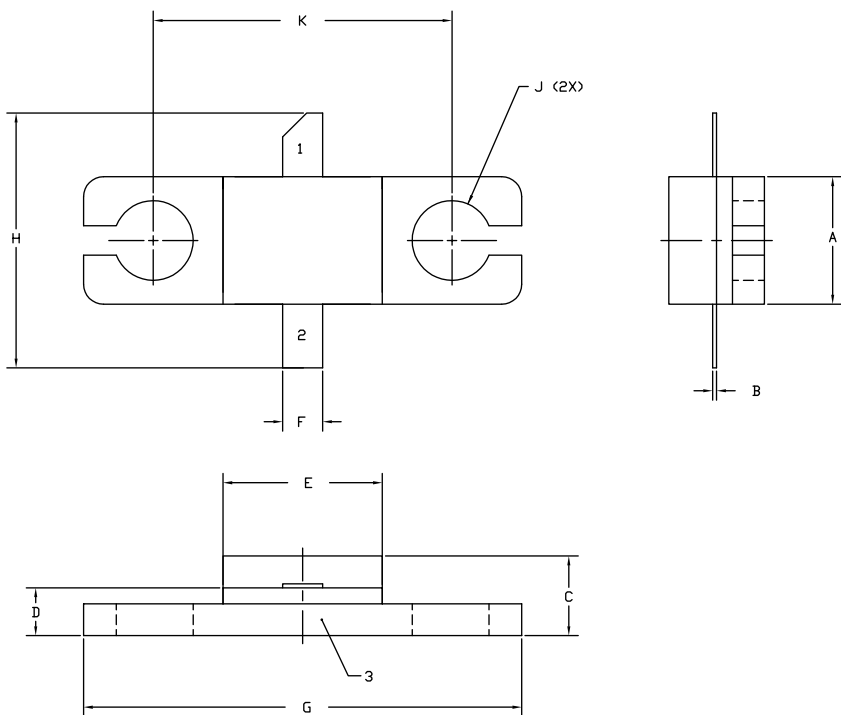

- NOTES:
1. DIMENSIONING AND TOLERANCING PER ANSI Y14.5M, 1982.
 2. CONTROLLING DIMENSION: INCH.
 3. ADHESIVE FROM LID MAY EXTEND A MAXIMUM OF 0.020" BEYOND EDGE OF LID.
 4. LID MAY BE MISALIGNED TO THE BODY OF THE PACKAGE BY A MAXIMUM OF 0.008" IN ANY DIRECTION.
 5. ALL PLATED SURFACES ARE NI/AU

DIM	INCHES		MILLIMETERS	
	MIN	MAX	MIN	MAX
A	0.155	0.165	3.94	4.19
B	0.004	0.006	0.10	0.15
C	0.115	0.135	2.92	3.43
D	0.057	0.067	1.45	1.70
E	0.195	0.205	4.95	5.21
F	0.045	0.055	1.14	1.40
G	0.545	0.555	13.84	14.09
H	0.280	0.360	7.11	9.14
J	Ø .100		2.54	
K	0.375		9.53	

- PIN 1. GATE
 PIN 2. DRAIN
 PIN 3. SOURCE

Product Dimensions CGH55015P2 (Package Type — 440196)

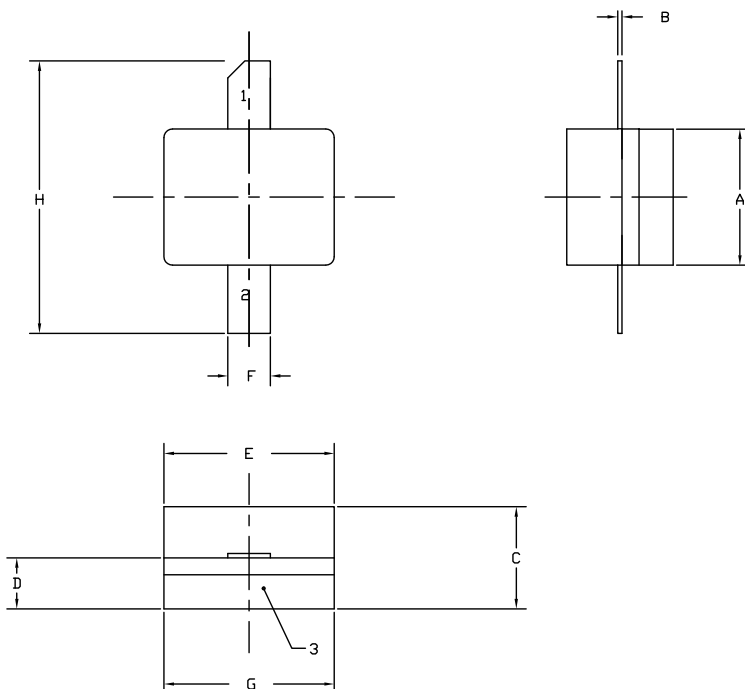



- NOTES:
1. DIMENSIONING AND TOLERANCING PER ANSI Y14.5M, 1982.
 2. CONTROLLING DIMENSION: INCH.
 3. ADHESIVE FROM LID MAY EXTEND A MAXIMUM OF 0.020" BEYOND EDGE OF LID.
 4. LID MAY BE MISALIGNED TO THE BODY OF THE PACKAGE BY A MAXIMUM OF 0.008" IN ANY DIRECTION.
 5. ALL PLATED SURFACES ARE NI/AU

DIM	INCHES		MILLIMETERS	
	MIN	MAX	MIN	MAX
A	0.155	0.165	3.94	4.19
B	0.003	0.006	0.10	0.15
C	0.115	0.135	2.92	3.17
D	0.057	0.067	1.45	1.70
E	0.195	0.205	4.95	5.21
F	0.045	0.055	1.14	1.40
G	0.195	0.205	4.95	5.21
H	0.280	0.360	7.11	9.14

- PIN 1. GATE
 PIN 2. DRAIN
 PIN 3. SOURCE

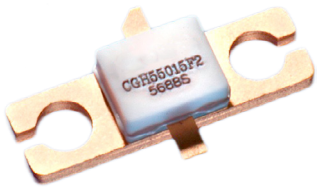
Product Ordering Information

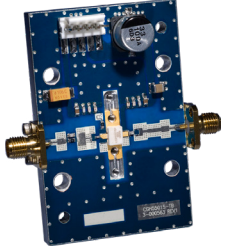
Order Number	Description	Unit of Measure	Image
CGH55015F2	GaN HEMT	Each	
CGH55015P2	GaN HEMT	Each	
CGH55015F2-AMP1	Test board with GaN HEMT installed	Each	

Notes & Disclaimer

MACOM Technology Solutions Inc. ("MACOM"). All rights reserved.

These materials are provided in connection with MACOM's products as a service to its customers and may be used for informational purposes only. Except as provided in its Terms and Conditions of Sale or any separate agreement, MACOM assumes no liability or responsibility whatsoever, including for (i) errors or omissions in these materials; (ii) failure to update these materials; or (iii) conflicts or incompatibilities arising from future changes to specifications and product descriptions, which MACOM may make at any time, without notice. These materials grant no license, express or implied, to any intellectual property rights.

THESE MATERIALS ARE PROVIDED "AS IS" WITH NO WARRANTY OR LIABILITY, EXPRESS OR IMPLIED, RELATING TO SALE AND/OR USE OF MACOM PRODUCTS INCLUDING FITNESS FOR A PARTICULAR PURPOSE, MERCHANTABILITY, INFRINGEMENT OF INTELLECTUAL PROPERTY RIGHT, ACCURACY OR COMPLETENESS, OR SPECIAL, INDIRECT, INCIDENTAL, OR CONSEQUENTIAL DAMAGES WHICH MAY RESULT FROM USE OF THESE MATERIALS.

MACOM products are not intended for use in medical, lifesaving or life sustaining applications. MACOM customers using or selling MACOM products for use in such applications do so at their own risk and agree to fully indemnify MACOM for any damages resulting from such improper use or sale.