

GaN Amplifier 28 V, 240 W

3.1 - 3.5 GHz



MACOM PURE CARBIDE™

CGH35240F

Rev. V1

Features

- Saturated Power: 240 W
- Large Signal Gain: 11.6 dB
- Drain Efficiency: 57%
- Internally Matched: 50 Ω
- High Temperature Operation
- RoHS* Compliant

Applications

- General Amplification
- S-Band RADAR

Description

The CGH35240F is a gallium nitride (GaN) amplifier designed specifically with high efficiency, high gain and wide bandwidth capabilities, which makes the CGH35240F ideal for 3.1-3.5 GHz S-Band radar amplifier applications.

The amplifier is supplied in a ceramic/metal flange package.



440201

Functional Schematic

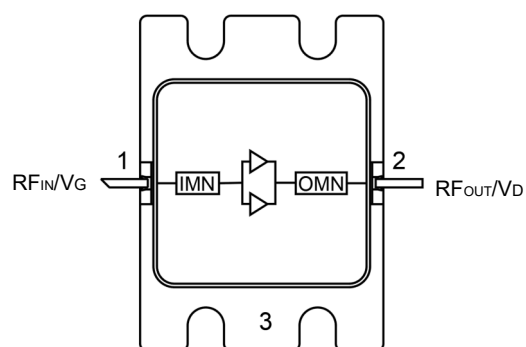

Pin Configuration

Pin #	Pin Name	Function
1	RF _{IN} / V _G	RF Input / Gate
2	RF _{OUT} / V _D	RF Output / Drain
3	Flange ²	Ground / Source

2. The flange on the package bottom must be connected to RF, DC and thermal ground.

Typical RF Performance:

Measured in Evaluation Test Fixture¹ at P_{IN} = 42 dBm, 300 μsec pulse width and 20% Duty Cycle.

- V_{DS} = 28 V, I_{DQ} = 1 A, T_C = 25°C

Frequency (GHz)	Output ¹ Power (W)	Power ¹ Gain (dB)	PAE ¹ (%)
3.1	250	12.1	60
3.3	225	11.6	57
3.5	220	11.4	48

1. Performance values and curves in this data sheet were measured in this fixture.

Ordering Information

Part Number	MOQ Increment
CGH35240F	Bulk
CGH35240F-AMP	Sample Board

* Restrictions on Hazardous Substances, compliant to current RoHS EU directive.

GaN Amplifier 28 V, 240 W

3.1 - 3.5 GHz



MACOM PURE CARBIDE™

CGH35240F

Rev. V1

RF Electrical Specifications: $T_A = +25^\circ\text{C}$, $V_{DS} = 28\text{ V}$, $I_{DQ} = 1\text{ A}$

Parameter	Units	Min.	Typ.	Max.	Conditions
Output Power at f = 3.1 GHz	W	210	250	—	$V_{dd} = 28\text{V}$, $I_{dq} = 1\text{ A}$, $P_{in} = 42\text{ dBm}$ Pulse Width = 300 μs , Duty Cycle = 20%
Output Power at f = 3.3 GHz	W	200	225	—	
Output Power at f = 3.5 GHz	W	180	220	—	
Power Gain at f = 3.1 GHz	dB	11	12	—	
Power Gain at f = 3.3 GHz	dB	10.8	11.5	—	
Power Gain at f = 3.5 GHz	dB	10.5	11.5	—	
Power Added Efficiency at f = 3.1 GHz	%	48	60	—	
Power Added Efficiency at f = 3.3 GHz	%	48	57	—	
Power Added Efficiency at f = 3.5 GHz	%	40	48	—	
Small-Signal Gain (S21)	dB	11.4	14	—	$V_{dd} = 28\text{V}$, $I_{dq} = 1\text{ A}$
Input Return Loss (S11)	dB	—	-9	-4.5	
Output Return Loss (S22)	dB	—	-10	-4.5	

Note: Final testing and screening for all amplifier sales is performed using the CGH35240F-AMP

DC Electrical Characteristics $T_A = 25^\circ\text{C}$

Parameter	Test Conditions	Symbol	Min.	Typ.	Max.	Units
Drain-Source Leakage Current	$V_{GS} = -8\text{ V}$, $V_{DS} = 120\text{ V}$	I_{DLK}	-	-	23.0	mA
Gate-Source Leakage Current	$V_{GS} = -8\text{ V}$, $V_{DS} = 10\text{ V}$	I_{GLK}	-8.0	-	-	mA
Gate Threshold Voltage	$V_{DS} = 10\text{ V}$, $I_D = 57.6\text{ mA}$	V_T	-3.8	-3.0	-2.3	V
Gate Quiescent Voltage	$V_{DS} = 28\text{ V}$, $I_D = 1\text{ A}$	V_{GSQ}	-	-2.7	-	V

Absolute Maximum Ratings^{1,2}

Parameter	Absolute Maximum
Pulse Width	1000 μsec
Duty Cycle	50 %
Drain-Source Voltage	120 V
Gate Voltage	-10, +2 V
DC Drain Current	8 A
Gate Current	60 mA
Input Power	43 dBm
Storage Temperature	-65°C to +150°C
Mounting Temperature ³	+245°C
Junction Temperature ^{4,5}	+225°C
Operating Temperature	-40°C to +150°C

1. Exceeding any one or combination of these limits may cause permanent damage to this device.
2. MACOM does not recommend sustained operation near these survivability limits.
3. Mounting temperature for 30 seconds.
4. Operating at nominal conditions with $T_J \leq +225$ C will ensure $MTTF > 1 \times 10^6$ hours.
5. Junction Temperature (T_J) = $T_C + \Theta_{jc} * (V * I)$
Typical thermal resistance (Θ_{jc}) = 0.5 °C/W for Pulse Width = 300 μs and Duty Cycle = 20 %.
 - a) For $T_C = +85$ °C,
 $T_J = 225$ °C @ $P_{diss} = 280$ W

Handling Procedures

Please observe the following precautions to avoid damage:

Static Sensitivity

These electronic devices are sensitive to electrostatic discharge (ESD) and can be damaged by static electricity. Proper ESD control techniques should be used when handling these devices.

Evaluation Test Fixture and Recommended Tuning Solution, 3.1 - 3.5 GHz

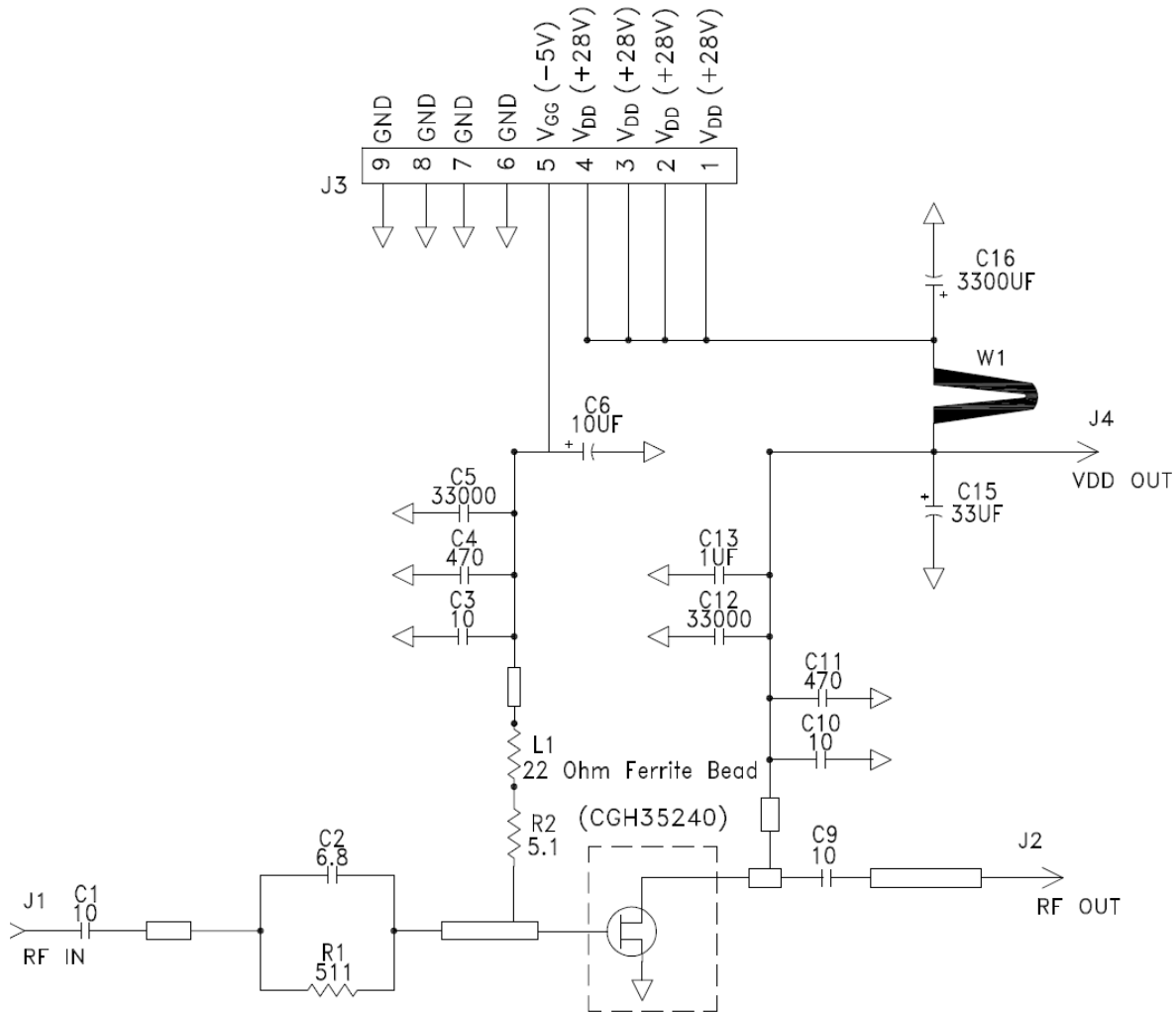

Description

Parts measured on evaluation board (30-mil thick RO4350B). Matching is provided using a combination of lumped elements and transmission lines as shown in the simplified schematic above. Recommended tuning solution component placement, transmission lines, and details are shown on the next page.

Biasing Sequence

Bias ON

1. Ensure RF is turned off
2. Apply pinch-off voltage of -5 V to the gate
3. Apply nominal drain voltage
4. Bias gate to desired quiescent drain current
5. Apply RF

Bias OFF

1. Turn RF off
2. Apply pinch-off voltage of -5 V to the gate
3. Turn-off drain voltage
4. Turn-off gate voltage

Evaluation Test Fixture and Recommended Tuning Solution, 3.1—3.5 GHz

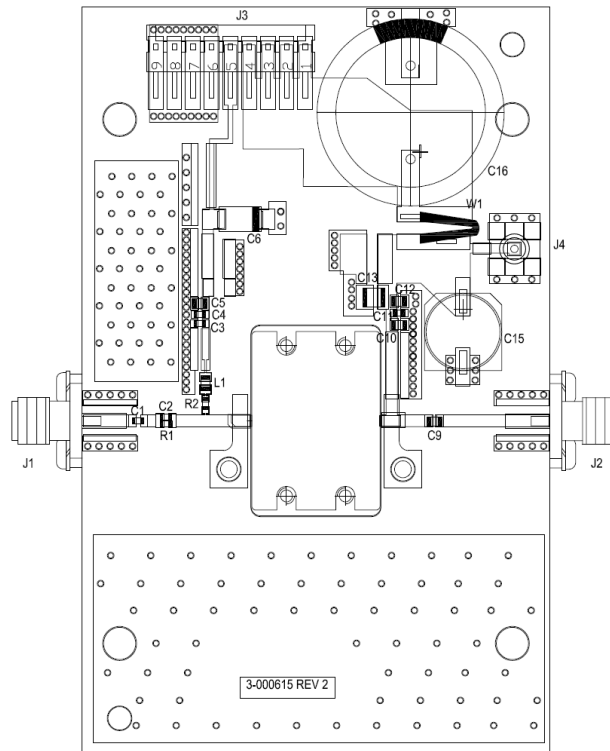

Assembly Parts List

Reference Designator	Description	Qty
R1	RES, 511 OHM, +/- 1%, 1/16W, 0603	1
R2	RES, 5.1, OHM, +/- 1%, 1/16W, 0603	1
C1, C3	CAP, 10.0pF, +/-5%, 250V, 0603, ATC600S	2
C2	CAP, 6.8pF, +/- 0.25pF, 250V, 0603, ATC600S	1
C4, C11	CAP, 470pF, +/-5%, 100V, 0603, X7R	2
C15	CAP, 33μF, 20%, G CASE	1
C5, C12	CAP, 33000pF, 0805, 100V, X7R	2
C13	CAP, 1.0μF, 100V, 10%, X7R, 1210	1
C6	CAP, 10μF, 16V, TANTALUM	1
C9, C10	CAP, 10pF, +/- 1%, 250V, 0805	2
C16	CAP, 3300μF, +/-20%, 100V, ELECTROLYTIC	1
J1, J2	CONN, SMA, PANEL MOUNT JACK, FL	2
J3	HEADER, RT>PLZ, 0.1CEN LK 9POS	1
J4	CONNECTOR, SMB, STRAIGHT, JACK, SMD	1
W1	CABLE, 18 AWG, 4.2	1
L1	FERRITE, 22 OHM, 0805, BLM21PG220SN1	1
-	PCB, RO4350, 2.5 X 4.0 X 0.030	1
Q1	CGH35240F	1

GaN Amplifier 28 V, 240 W

3.1 - 3.5 GHz



CGH35240F

Rev. V1

MACOM PURE CARBIDE™

Typical Performance Curves as Measured in the 3.1– 3.5 GHz Evaluation Test Fixture

Pulse width = 300 μ s, Duty Cycle = 20%, P_{IN} = 42 dBm, V_{DS} = 28V, I_{DQ} = 1 A (Unless otherwise noted)

For Engineering Evaluation Only – This data does not Modify MACOM's Datasheet Limits.

S11, S21, & S22 vs. Frequency

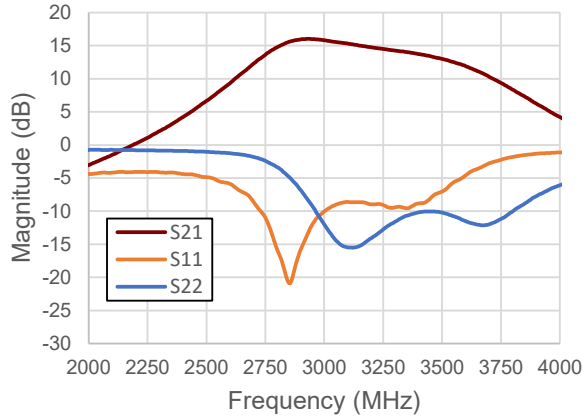

Output Power and Gain vs. Frequency

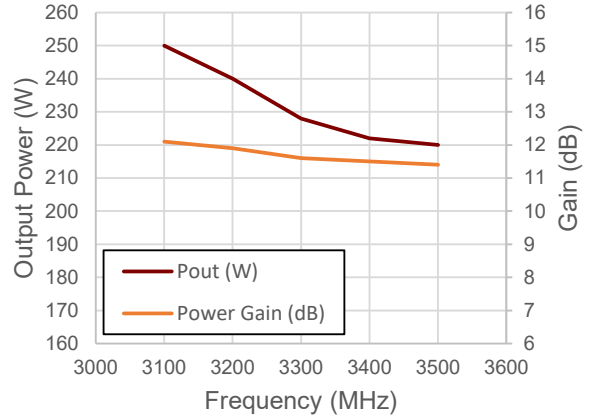

Output Power vs. Input Power and Frequency

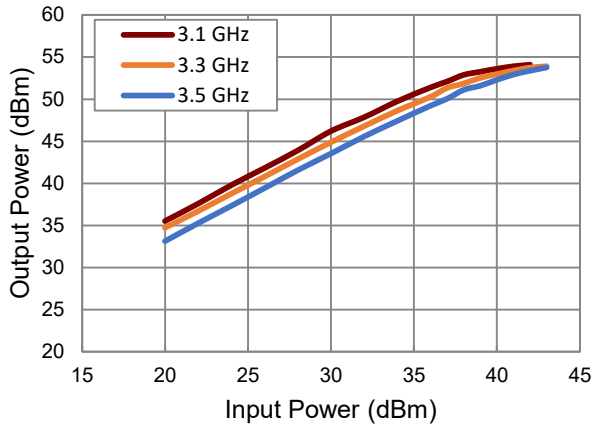

PAE & Gain vs. Input Power and Frequency

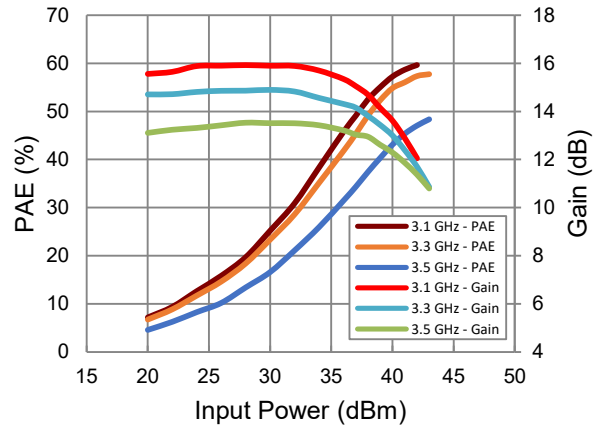

Output Power & PAE vs. Input Power and Frequency

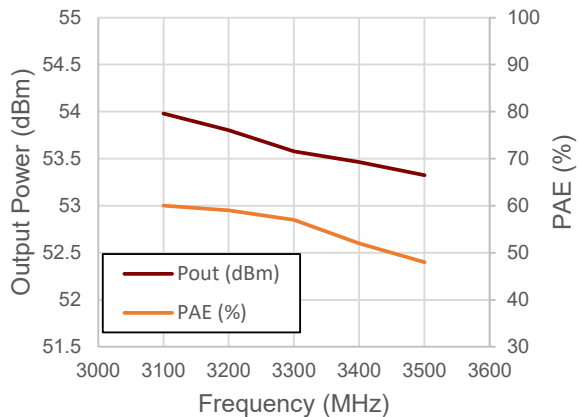

Lead-free 440201 Package Dimensions

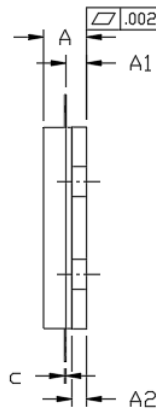
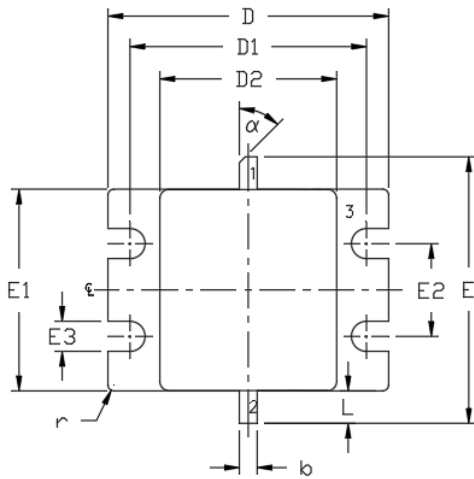

PIN 1. GATE
2. DRAIN
3. SOURCE

NOTES:

1. DIMENSIONING AND TOLERANCING PER ANSI Y14.5M - 1994.
2. CONTROLLING DIMENSION: INCH.
3. ADHESIVE FROM LID MAY EXTEND A MAXIMUM OF 0.020" BEYOND EDGE OF LID.
4. LID MAY BE MISALIGNED TO THE BODY OF PACKAGE BY A MAXIMUM OF 0.008" IN ANY DIRECTION.

DIM	INCHES		MILLIMETERS		NOTES
	MIN	MAX	MIN	MAX	
A	0.128	0.148	3.25	3.76	
A1	0.057	0.067	1.45	1.70	
A2	0.035	0.045	0.89	1.14	
b	0.055	0.065	1.40	1.65	2x
c	0.004	0.007	0.08	0.15	
D	0.948	0.958	24.08	24.33	
D1	0.798	0.808	20.27	20.52	
D2	0.595	0.605	15.11	15.37	
E	0.880	0.930	22.35	23.62	
E1	0.680	0.694	17.27	17.63	
E2	0.310	0.320	7.87	8.13	
E3	0.097	0.107	2.46	2.72	4x
L	0.095	0.125	2.41	3.18	2x
r	0.02	TYP	0.51	TYP	4x
α	45°	REF	45°	REF	

MACOM Technology Solutions Inc. ("MACOM"). All rights reserved.

These materials are provided in connection with MACOM's products as a service to its customers and may be used for informational purposes only. Except as provided in its Terms and Conditions of Sale or any separate agreement, MACOM assumes no liability or responsibility whatsoever, including for (i) errors or omissions in these materials; (ii) failure to update these materials; or (iii) conflicts or incompatibilities arising from future changes to specifications and product descriptions, which MACOM may make at any time, without notice. These materials grant no license, express or implied, to any intellectual property rights.

THESE MATERIALS ARE PROVIDED "AS IS" WITH NO WARRANTY OR LIABILITY, EXPRESS OR IMPLIED, RELATING TO SALE AND/OR USE OF MACOM PRODUCTS INCLUDING FITNESS FOR A PARTICULAR PURPOSE, MERCHANTABILITY, INFRINGEMENT OF INTELLECTUAL PROPERTY RIGHT, ACCURACY OR COMPLETENESS, OR SPECIAL, INDIRECT, INCIDENTAL, OR CONSEQUENTIAL DAMAGES WHICH MAY RESULT FROM USE OF THESE MATERIALS.

MACOM products are not intended for use in medical, lifesaving or life sustaining applications. MACOM customers using or selling MACOM products for use in such applications do so at their own risk and agree to fully indemnify MACOM for any damages resulting from such improper use or sale.